



SEMINAR SERIES 2017

NZS 3101 UPDATE

Presented by

Concrete NZ – Learned Society

Seminar Notes

(TR66)

Presented by
Concrete NZ – Learned Society

**The Concrete NZ - Learned Society acknowledges
the support of the following organisations for
making this seminar series possible:**

Holmes Consulting

www.holmesgroup.com



www.engineering.auckland.ac.nz

Presenters:

Rick Henry, University of Auckland, Faculty of Engineering

Alistair Russell, Holmes Consulting

NZS 3101:2006 Amendment 3

Seminar Notes Directory

Session 1	Introduction & Background Displacement Critical Elements <i>Alistair Russell / Rick Henry</i>
Session 2	Precast Seating & Bearing Deformation Compatibility <i>Alistair Russell / Rick Henry</i>
Session 3	Materials, Durability, Fire, Couplers Embedded Anchors, Walls <i>Alistair Russell / Rick Henry</i>
Session 4	Walls (continued), Curvature Limits & Analysis Creep & Shrinkage, Columns, Torsion <i>Alistair Russell / Rick Henry</i>
APPENDIX A	NZS 3101:2006 Amendment 3 - List of Key Changes
REFERENCE	Amendment 3 to NZS 3101 <i>Dene Cook, Richard Fenwick, Alistair Russell (2014 NZCIC)</i> Design of RC Walls Post the Canterbury Earthquakes <i>Alistair Russell, Rick Henry, Richard Fenwick (2015 NZCIC)</i>

Session 1

Introduction & Background
Displacement Critical Elements

Alistair Russell / Rick Henry

NZS 3101:2006 Amendment 3

Session 1

Alistair Russell
Rick Henry

Order for the day

	When	Topics	
Session 1	1:30 – 2:15	<ul style="list-style-type: none"> • Intro and Background • Displacement critical elements 	
Session 2	2:15 – 3:00	<ul style="list-style-type: none"> • Precast seating & bearing • Deformation compatibility 	
Break	3:00 – 3:30		
Session 3	3:30 – 4:15	<ul style="list-style-type: none"> • Materials • Durability, Fire • Couplers 	<ul style="list-style-type: none"> • Embedded anchors • Walls
Session 4	4:15 – 5:00	<ul style="list-style-type: none"> • Walls (continued) • Curvature limits & analysis 	<ul style="list-style-type: none"> • Creep & Shrinkage • Columns • Torsion

Why Amendment?

- Canterbury Earthquakes
 - CERC
 - SESOC interim guidance
- Misc changes
 - SESOC Journal (August 2010)

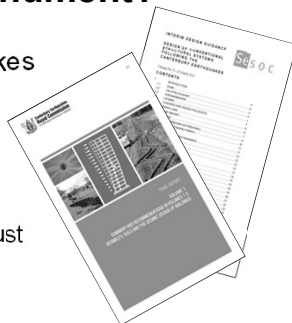

Timeframe

- Feb 2014 – Initiation
- October 2014 – Public Draft
- January 2015 – review public draft
...Pause...
- July 2016 – August 2017 – finalise
- Nov 2017 – MBIE B1/VM1 – consultation
- 2019 – new revision might start?

Standards NZ



3101 & Building Code

B1/VM1
Method of verifying compliance with clause B1 (structure)

Also
B2/VM1 (Durability)
C (Fire)

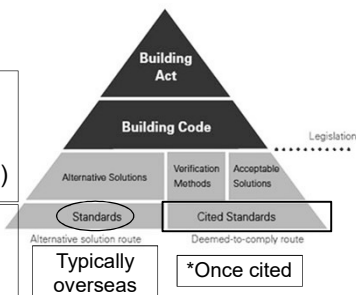

Committee

- Dene Cook – (previous) chair
- Richard Fenwick – CERC
- UoA & UC
- BRANZ, IPENZ, NZTA, SESOC, MBIE, BusinessNZ, NZSEE
- CCANZ, PrecastNZ, NZCS [= ConcreteNZ]

Committee

Angela Lui	Carl Ashby
Nicholas Brooke	David Wood
Alistair Russell	Rod Fulford
Dene Cook	Des Bull
Richard Fenwick	Rajesh Dhakal
S R Uma	Stefano Pampanin
Donald Kirkcaldie	Rick Henry
Graeme Lawrance	Jason Ingham

Terms of Reference

- Develop amendment to NZS3101 with due consideration of:
 - Recommendations of Canterbury Earthquake Royal Commission
 - SESOC interim design guidance
 - SNZ data base of questions/ actions
- Emphasis on big picture issues, recognise that some "judgments" will require further research



Royal Commission

- Nearly 200 Recommendations
- 12+ related to NZS 3101:2006
 - Peak actions
 - Elongation
 - Single cracks
 - Ductile walls – detailing and behaviour



CERC Recommendations

#	Topics	Changes
(1170.5) { 38	Peak/Design drift	✓
	39 Stairs and ramps should sustain 1.5 x peak drift	✓
40	Review of rate of loading on concrete structures	(✓) Research
41	Research into yield penetration in beam-column joints	Research
42	Single cracks in structural walls	✓



CERC Recommendations

#	Topics	Changes
43	Ductile wall detailing (transverse reinforcement)	✓
44	Axial load ratio on walls (+ research)	✓
45	Research into stiffness degradation in plastic hinges	Research
46	Magnitude of elongation to be considered in design	✓
47	Awareness of elongation effects, guidance in commentary	✓



CERC Recommendations

#	Topics	Changes
48	Elongation at corners of buildings, and floor diaphragms	✓
49	Axial compression forces in beams due to floor restraint	✓
50	Low friction bearing strips for TT units [and precast in general]	✓
51	Stirrups lapped in cover concrete <50% of stirrup	✓

Key Recommendations

Peak/Design drift	Commentary on elongation
Stairs and ramps should sustain 1.5 x peak drift	Elongation at corners of buildings
Single cracks in structural walls	Axial compression in beams due to floor restraint
Ductile wall detailing (transverse reinforcement)	Low friction bearing strips for TT units
Axial load ratio on walls (+ research)	Stirrups lapped in cover concrete <50% of stirrup
Magnitude of elongation to be considered in design	

Layout of NZS 3101:2006

- 19 chapters & 4 appendices
- Commentary follows (pdf)

*Errors in initial pdf



Layout of NZS 3101:2006

Chapter	Topics	Changes
1	General	✓
2	Design procedures: E.g. Curvature limitations	✓✓✓
3	Durability	✓
4	Fire	✓
5	Materials	✓✓

Layout of NZS 3101:2006

Chapter	Topics	Changes
6	Structural Analysis	✓✓
7	Flexure, Shear & Elongation	✓✓
8	Reinforcement detailing	✓✓
9	Beams & slabs	✓
10	Columns	✓

Layout of NZS 3101:2006

Chapter	Topics	Changes
11	Walls	✓✓✓✓
12	Two way slabs	—
13	Diaphragms	✓
14	Footings, piles & pilecaps	—
15	Beam-column joints	✓

Layout of NZS 3101:2006

Chapter	Topics	Changes
16	Bearing, brackets & corbels	✓✓
17	Anchors and fixings	✓✓
18	Precast	✓✓✓
19	Prestressed	—

Layout of NZS 3101:2006

Appendix	Topics	Changes
A	Strut and Tie	—
B	PReSS	—
No Appendix C – (C for Commentary)		
D	Actions in Frames and Walls	—
E	Creep and Shrinkage	*New*

List of Key Changes

At end of notes

NZS 3101:2006 Amendment 3 List of key changes

The following list contains a summary of the key changes in amendment 3. In addition to the clause changes summarised here there are also extensive editorial amendments (corrections and clarifications) as well as changes to definitions and notation.

Shading is used to highlight the major topics and cross-references to the seminar slides is provided.

Chapter	Clause	Description	Seminar slides
Ch. 1	1.1.1.1	Minimum requirements clarified	S1-23,24
	1.5	New definitions (e.g. design/peak drifts)	S1-28,30
	2.2.3	Inclusion of stair & ramps and precast floor & cladding in robustness requirements (see also 2.6.10.4)	S2-4
	2.3.2.2	Strength reduction factors (singly reinforced walls, bearing)	S3-35 S2-62
	2.3.2.3	Tensile strength of concrete	S3-7

Background to Changes

- Two NZ Concrete Conference papers
- At end of notes
- Based on 2014 public draft
 - Some clauses numbering not correct
 - Some further changes since



General Requirements

Clause 1.1.1.1

This Standard sets out the minimum requirements for the design of reinforced and prestressed concrete structures. In addition to satisfying these requirements every load or force acting on a structure shall have one or more dependable load paths that can transfer the force to the foundation soils. Each load path shall satisfy the fundamental structural design requirements of equilibrium and displacement compatibility.

General Requirements

Clause C1.1.1.1

The Standard sets out the minimum requirements. However, not every detail that may arise in a design can be covered in the Standard.

Where this situation arises the design should be based on first principles and the fundamental concepts on which the design of concrete structures is based.

Displacement critical elements

- “Binary” engineering – on or off
- Must estimate *maximum displacement* to ensure no loss of support

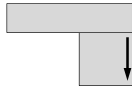

Stairs & Ramps

- Critical structures for egress
- Same issues for steel and concrete stairs
- DBH / MBIE:
Practice Advisory 13 - Egress Stairs

Stairs & ramps

Stairs, ramps
– *Functional* after peak
MCE displacements
(not undamaged)

Panels
– *Attached* after peak
MCE displacements



2.6.10.4

PEAK displacements

Clause 1.5
(Definitions)

- Interstorey drift:
 - Peak interstorey drift = design interstorey drift / S_p
- S_p (Structural performance factor):
 - Accounts for robustness of ductile systems
 - Peak accelerations that only occur once in EQ
 - Design drifts sustained several times during EQ

• Peak deformations ARE critical ($\times 1/S_p$)

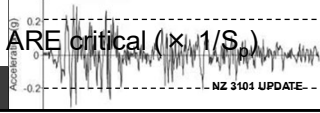

MCE displacements

- MCE – Maximum Considered Earthquake
- MCE interstorey drift $1.5 \times$ larger than DBE EQ
- Displacements during earthquakes larger than ULS design ARE critical (50% increase)

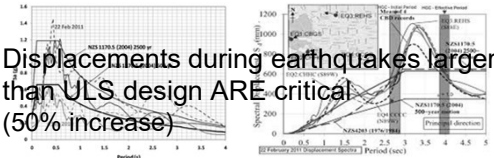

Peak MCE Displacements

MCE $\rightarrow 1.5 \times$ ULS Design Displacement
 Peak $\rightarrow S_p$

- MCE \neq 3rd limit state
 - Displacement critical elements
 - Stairs, ramps
 - Cladding panels & fall hazard elements
 - Precast seating
- } Egress

Displacement Critical Items

- 2.6.10.4
 - Stairs, ramps
 - Cladding panels & fall hazard elements (17)
- 18.8
 - Precast seating

NZS 1170.5 – Sliding Ledges

- **2.6.10.4** Stairs, ramps and panels
“Notwithstanding the requirement to comply with the provisions of Section 8 of NZS 1170.5”
- NZS 1170.5, clause 8.8
“Minimum dimensions for a sliding ledge”

$$\frac{2}{S_p} \times \text{ULS Design Displacement}$$

Elongation

- New clause – 7.8
- First published in NZ ~ 1993
 - Known about since 1980s
- What is elongation?

Geometric Elongation

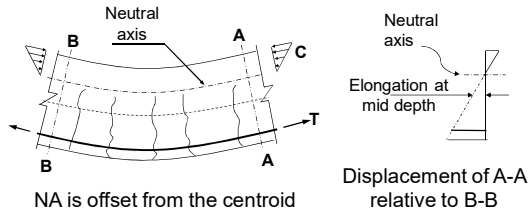

Tensile strains > compression strains

Plastic Hinge Elongation

- Reversing inelastic deformation
 - Plane sections do not remain plane
- Yielding of reinforcement
- Dislocation of aggregate particles
 - Cracks do not fully close

Plastic Hinge Elongation

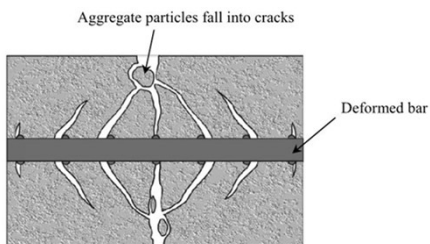

Beam elongation

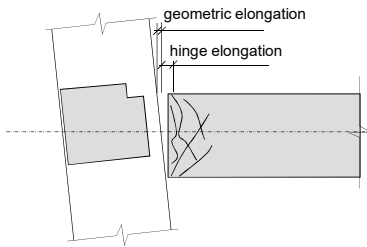

Restrained elongation

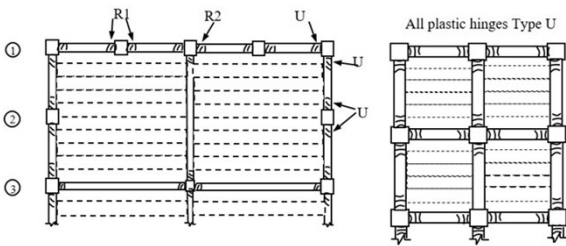

Restrained elongation

Precast floor unit spanning a plastic hinge (partially) restrains elongation

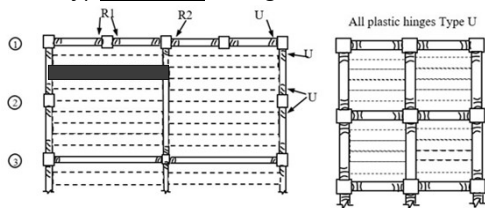

Restrained elongation

U, R2 – no restraint

R1 – elongation is half

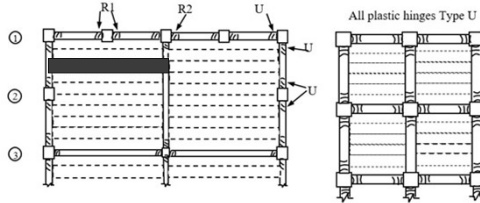

Amount of Elongation

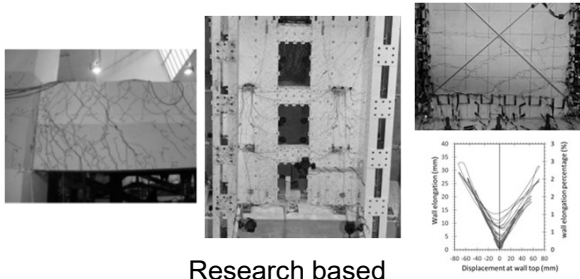

7.8.2

Magnitude of Elongation

Equation	For
$\sigma_{e,l} \approx \frac{\theta_m}{2} (d - d')$	Unidirectional plastic hinges beams Eq. 7-15(a)
$\sigma_{e,l} \approx 2.6 \frac{\theta_m}{2} (d - d') \leq 0.036h_b$	Reversing plastic hinges beams Eq. 7-15(b)
$\sigma_{e,l} \approx \theta_m (0.5L_w - c)$	Walls $c \leq 0.5L_w$ Eq. 7-15(c)

$\theta_m = \text{Total rotation in plastic hinge}$

7.8.3

1-43

Magnitude of Elongation

- MCE Elongation: $1.5 \times \sigma_{el}$
- Peak MCE Elongation: $\frac{1.5}{S_p} \times \sigma_{el}$
- MCE Elongation $\leq 0.036h_b$
- No elongation for SLS

1-44

Elongation

- Where elongation needs to be considered (2.6.5.10)
- Magnitude of elongation (7.8)
- Detailing for elongation:
 - Stairs and ramps (2.6.10.4, 18.7.6)
 - Cladding panels and fixings (17.6.2)
 - Support of floor elements (18.7.4, 18.8.1)
 - Coupling beams (11.4.9.2)
 - Axial forces induced in walls (11.4.1.4)

1-45

Plastic Elongation of the beams – push the columns

- Loss of floor supports and load paths.

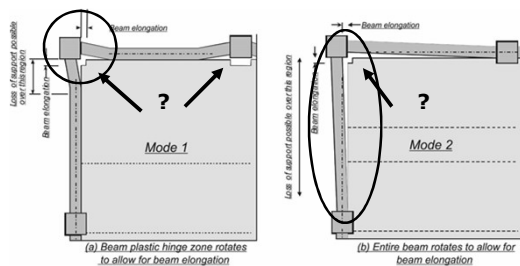

Corner elongation

- Loss of floor supports and load paths.
- **2.6.5.10(f)** specifically addresses this
“Consider the interconnection between floors with precast units and lateral force resisting elements”
- **10.3.6** Tie columns and floors

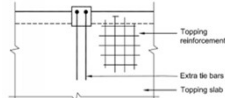
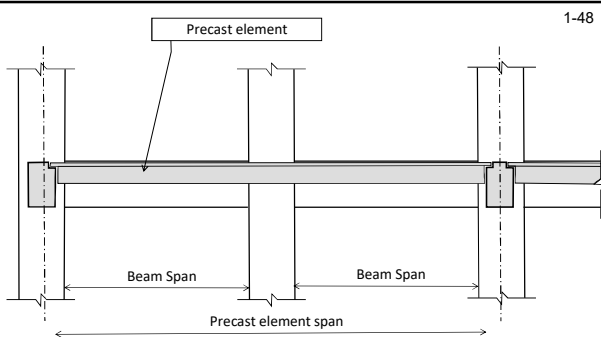

Figure C10.2 – Reinforcement to tie exterior columns to floors

Frame Dilatancy

- Beams increase in length
- Columns in a frame move apart
- Frames re-centred, but residual ‘spread’ of columns = “Frame dilatancy”



a) Before earthquake

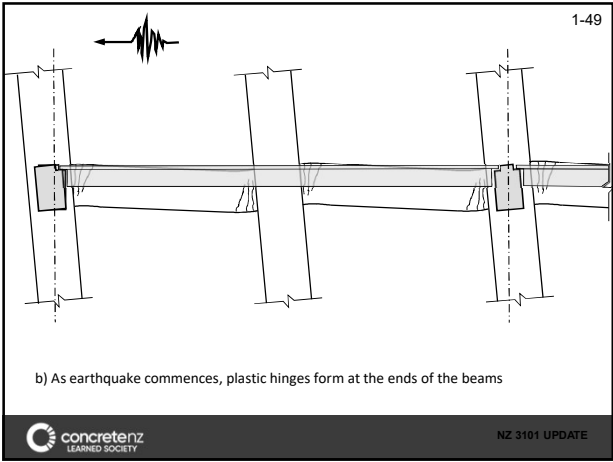

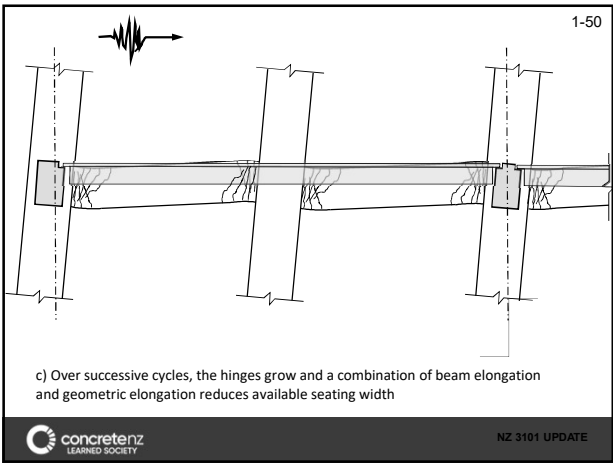

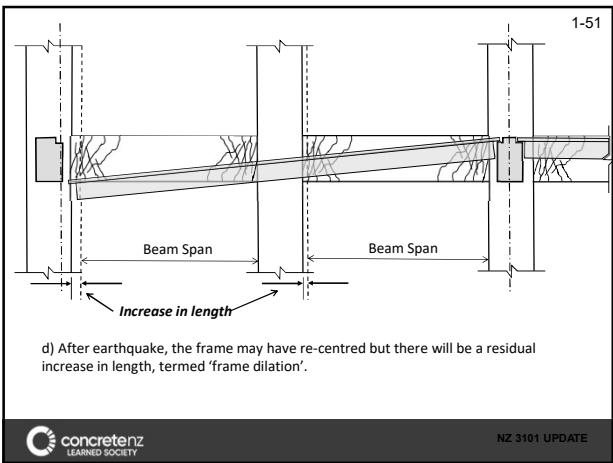

Elongation

- As well as “beam stretch”
- Induces axial loads also – particularly in floors [CERC #49]
 - (also provides restraint to elongation: *R1 hinge*)
- Software doesn’t account for elongation (typically)
- Very wide cracks in floors → possible loss of diaphragm action (*existing buildings*)

Elongation

#	Topics	Changes
48	Elongation at corners of buildings, and floor diaphragms	✓
49	Axial compression forces in beams due to floor restraint	✓
50	Low friction bearing strips for TT units [and precast in general]	✓
51	Stirrups lapped in cover concrete <50% of stirrup	✓

Key Recommendations

✓ Peak/Design drift	✓ Commentary on elongation
✓ Stairs and ramps should sustain 1.5 x peak drift	✓ Elongation at corners of buildings
Single cracks in structural walls	Axial compression in beams due to floor restraint
Ductile wall detailing (transverse reinforcement)	Low friction bearing strips for TT units
Axial load ratio on walls (+ research)	Stirrups lapped in cover concrete <50% of stirrup
✓ Magnitude of elongation to be considered in design	

Summary

- Displacement critical elements
- On or off!
 MCE → $1.5 \times$ ULS Design Displacement
 Peak → S_p
- Account for elongation

NZS 3101:2006 Amendment 3

Alistair Russell
 Rick Henry
alistairr@holmesgroup.com

Session 2

Precast Seating & Bearing
Deformation Compatibility

Alistair Russell / Rick Henry

NZS 3101:2006 Amendment 3

Session 2

NZS 3101:2006 Amendment 3

Session 2

Alistair Russell
Rick Henry

Session 2

- Ch. 18 Precast concrete
 - Deformation compatibility
 - Stairs
 - Floors

- Ch. 16 Bearing strength, brackets, corbels

Ch. 18 – Precast Concrete

- Deformation focus (stairs, cladding, floors)



Ch. 18 – Precast Concrete

- Precast floor unit seating – significant new research & earthquake observations



Deformations

- Ch. 2:
 - 2.2.3(d): Stairs & ramps functional after peak MCE deformations
 - 2.2.3(e): Precast floors and cladding must not collapse at peak MCE deformations
 - 2.6.10.4: Repeats stairs, ramps, cladding requirements (secondary elements)
- 18.3.3: Repeats definition of peak deformations

18.3.3 Consider serviceability and ultimate limit states
 Deflections, end rotations and lateral displacements shall be considered in the ultimate and serviceability limit states, and for a maximum considered earthquake seismic event where specifically required in a clause. Peak deformations shall be taken as 1/5_s times the corresponding design deformation given in NZS 1170.5 or other referenced loading standard for the limit state being considered, and the corresponding maximum considered earthquake value is 1.5 times the design ultimate limit state value. Hence a peak maximum considered earthquake deformation is 1.5/5_s times the design ultimate limit state deformation given in NZS 1170.5.

Stairs and Ramps

18.7.6 Precast stairs and ramps

The supports of stairs and access ramps shall satisfy 2.2.3(d) and 2.6.10 and be capable of sustaining the inter-storey drift specified for a sliding ledge support in NZS 1170.5, in addition to an appropriate allowance for construction tolerance and potential elongation effects. Allowance is also to be made for friction forces induced by sliding from thermal movements and movements resulting from seismic and other effects.

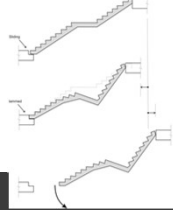
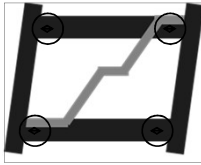

Stairs and Ramps

- **C18.7.6:** ...“Stairs should typically be detailed with a fixed top connection and sliding base connection”...

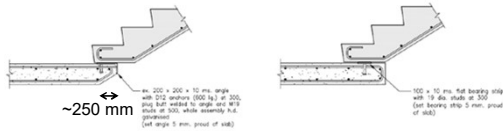
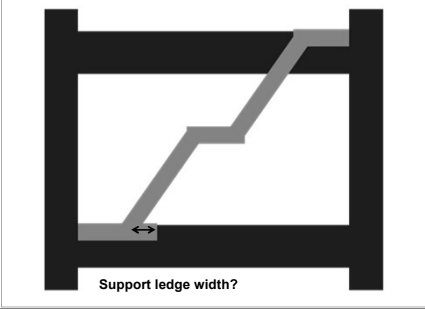

Figure C18.10 - Typical stair details

Stair Seating Design Example

2-10

Stairs & Ramps sliding at one end



Support ledge width?

concretenz
LEARNED SOCIETY

NZ 3101 UPDATE

2-11

Interstorey Drift

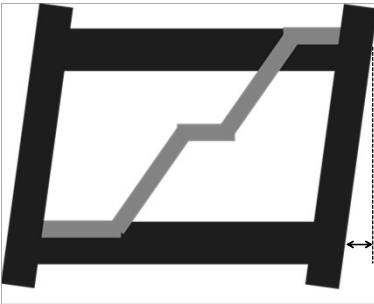

Design interstorey drift:
= 54 mm
(~1.5% for 3.6m storey height)

Sp = 0.7

Peak interstorey drift @ MCE
(as per 1170.5 8.8):
= $72 \times 2/0.7$
= 154 mm

concretenz
LEARNED SOCIETY

NZ 3101 UPDATE

2-12

Elongation

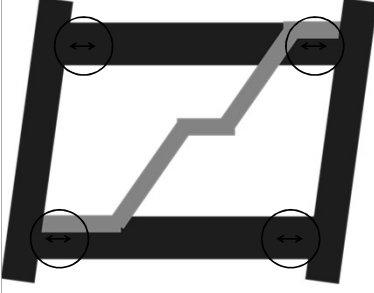

Sliding at one end:
→ 2 hinges per storey

Elongation per hinge (7.8):

$$\sigma_{ei} = 2.6 \frac{\sigma_m}{2} (d - d') \leq 0.036 h_e$$

= $0.036 \times 800 \text{ mm } (h_e)$
= 29 mm

Elongation per storey per stair:
= 2×29
= 58 mm

concretenz
LEARNED SOCIETY

NZ 3101 UPDATE

Tolerances

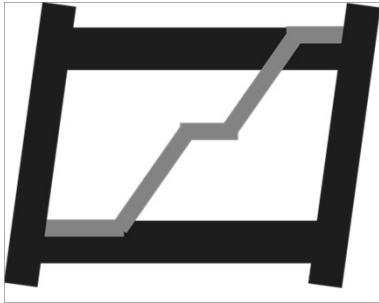

Assume tolerances of 20 mm
(in accordance with NZS 3109 & CAE precast guidelines 'Grey book')

Total Support Ledge Width

- Required width = $154 + 58 + 20 = \underline{232 \text{ mm}}$

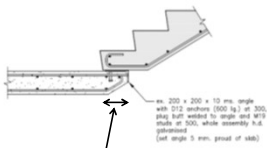

Armoured ledge:
232 mm + bearing width

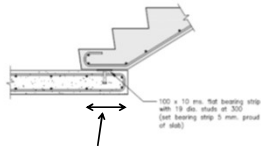

Unarmoured ledge:
232 mm + bearing width
+ allowance for spalling

Precast Floors

Precast Floors

- **2.2.3(e):** Must not collapse at MCE deformations
- **18.6.7.1:** Floors designed to withstand deformations due to:
 - Peak interstorey drift associated with MCE
 - Elongation demands (as per 7.8)
 - Allowance for construction tolerances, creep, shrinkage, thermal effects

Link slabs

- **18.6.7.2:** Link slabs (“insitu edge slab”) should be placed between hollowcore and any adjacent structural component (beam, wall, EBF)

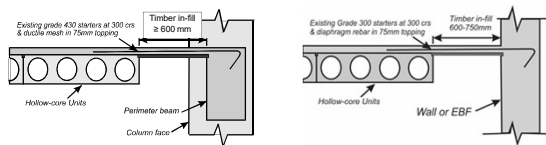

Precast Floor Unit Seating

- **18.7.4:**
 - Minimum seating lengths
 - Use low-friction bearing strip (all unit types)
 - Armouring (if used) should resist all forces and engage reinforcement in supporting member
 - Hollowcore support detail – no change from previous

Precast Floor Unit Seating

- **18.7.4.3: Minimum seating lengths**
(nominally ductile structures with no limited ductile or ductile plastic regions)

Greater of:

- 1/180 clear span
- 75mm (50mm solid slabs)
- Sum of:
 - Bearing in 16.3 or 10mm
 - Spalling of end of precast floor unit (30mm, unless armoured)
 - Spalling of support ledge (cover or 30mm, unless armoured)
 - Allowance for creep, shrinkage, thermal movements

Precast Floor Unit Seating

- **18.8.1: Seating lengths for ductile structures**
(structures with limited ductile or ductile plastic regions)

Sum of:

- Bearing in 16.3 or 10mm
- Elongation @ MCE ($1.5/S_p \times 7.8$ requirements)
- Reduced seating due to support beam twisting
- Spalling of support ledge:
 - Edge of support to centreline of long reo. (hinge region)
- Spalling of end of precast floor unit (as per 18.7.4.3)
- Allowance for creep, shrinkage, thermal, tolerances

Precast Floor Seating Design Example

Precast Floor Example

- Example in C18.8.1:
 - Rib and timber infill floor (depth of 225mm)
 - Ductile frame building
 - Beam span = 8m
 - Beam depth = 700mm
 - Column width = 800mm
 - Floor unit seated 125mm above the beam centerline

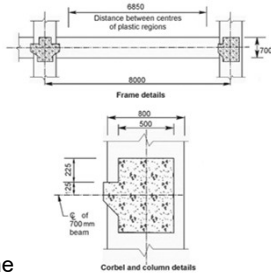

Precast Floor Example

- Rib and timber infill

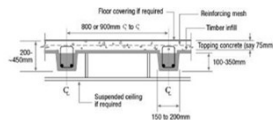
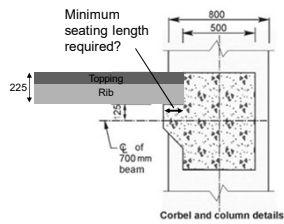

Precast Floor Example

- 18.8.1(a): Bearing length
 - Calculated in accordance with bearing stress limits in 16.3 (see later slides)
 - Taken as 10 mm for this example

Precast Floor Example

- 18.8.1(b): Spalling of support beam ledge

- In ductile detailing length & ledge not armoured
- spalling to centreline of long reinforcement

= cover (25) + stirrup (16) + $d_b/2$ (8)
 = 49 mm

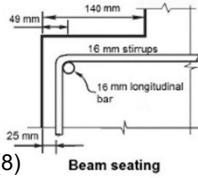

WLG: Support Spalling

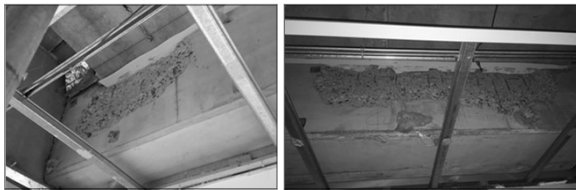

Precast Floor Example

- 18.8.1(e): Spalling of end of precast floor unit

- Unit end is not armoured
- 30 mm unit spalling

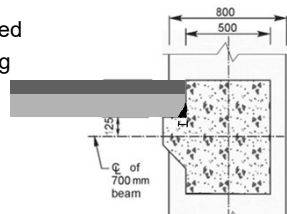

Precast Floor Example

- 18.8.1(f): Shrinkage
 $= 0.5 \text{ mm/m} \times 7.5\text{m} / 2$ ← Shared at each end
 $= \underline{2 \text{ mm}}$
- 18.8.1(g): Tolerances
 [as per NZS 3109 – see next slide]
 $= \underline{17 \text{ mm}}$

Precast Floor – Tolerances

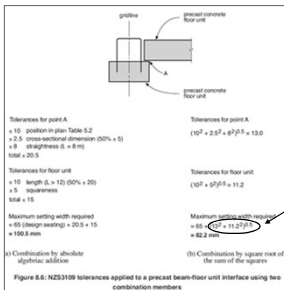

- From: "Guidelines for the use of Structural Precast Concrete in Buildings" – 'grey book'
- Potential lost seating
 $= \underline{17 \text{ mm}}$

Precast Floor Example

- 18.8.1: Total
- Min seating length = $10 + 25 + 4 + 49 + 30 + 2 + 17$
 $= \underline{137 \text{ mm}}$
- Specify **140 mm** seating length

Precast Floor Seating Design Example 2

Precast Floor Example 2

- Repeat example for nominally ductile building
 - Rib and timber infill floor (depth of 225mm)
 - Frame building – no limited ductile or ductile hinges
 - Beam span = 8m
 - Beam depth = 700mm
 - Column width = 800mm

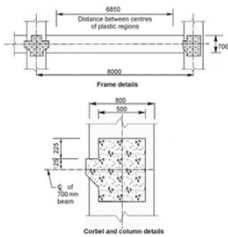

Precast Floor Example 2

- Rib and timber infill

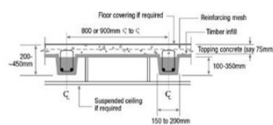
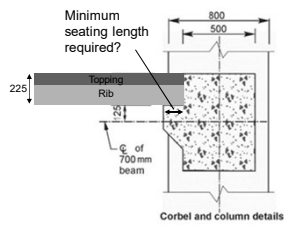

Precast Floor Example 2

- 18.7.4.3(c):
 - i. Bearing length in accordance with 16.3. Taken as 10 mm for this example.
 - ii. Spalling of end of rib = 30 mm
 - iii. Spalling of support ledge = cover = 25 mm
 - iv. Shrinkage & tolerances (as before) = 19 mm

Total = 10 + 30 + 25 + 19 = **84 mm** > 75 mm (min)

Hollowcore Support Damage

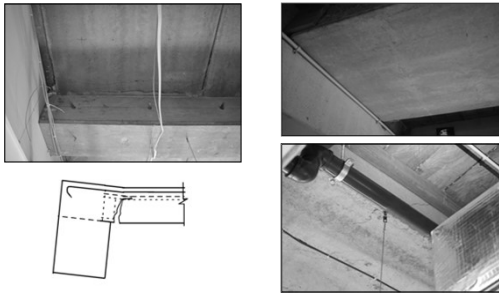

Hollowcore Support Detail

- **18.7.4.4:** All buildings incorporating hollowcore
 - Calculations or tests to peak MCE demands
 - C18.6.7(e) detail

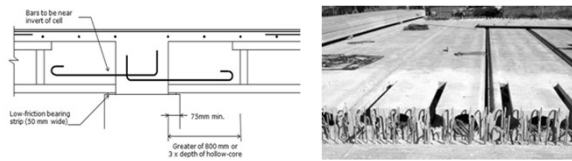

Rib Support Damage

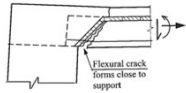
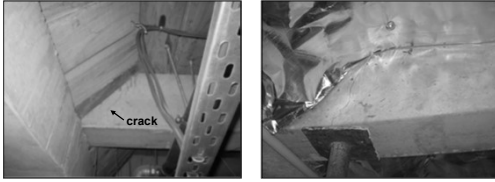

Support details - Ribs

- 18.8.2: Ductile buildings
 - Ribs shall not be restrained against rotation

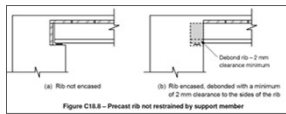
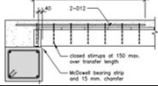

Figure C18.8 - Precast rib not restrained by support member



SESOC interim design guidance



Support details - Tees

- 16.3: Bearing stresses
- 18.7.4 & 18.8.1: Spalling
 - C18.8.1: Bearing stresses in 16.3 may require tees with high reactions (long span) to be armoured



Statistics House

- Significant elongation & frame dilatancy (100-150 mm)
 - Sliding detail at one end of tee
 - Seating reduction ~ 60 mm
- Flange supported double tees
 - Loop bar detail
 - Spalling
 - Delamination of topping



Flange Hung Tees - Loop Bar

- Concerns raised in 2009 (Fenwick et al. 2009 SESOC Journal)
- Already non-compliant with NZS 3101
- No longer in use
- MBIE proposal to formally ban

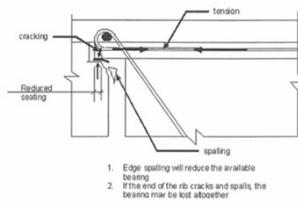

Frame Dilatancy

18.8.3.2 Frame dilatancy
Adequate support shall be provided to precast flooring units to take account of inelastic actions of ductile frames including the effects of frame dilatancy.

- Accumulation of elongation in frames
 - multiple plastic hinges
 - e.g. Statistics House

Tee Support Example

- 18.8.1(a): Bearing length
 - As per 16.3 = 20 mm (smaller bearing area for tees)

Tee Support Example

- Frame deformations:

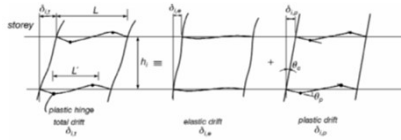

- ULS design column plastic drift = 0.0153 rad
- ULS design beam plastic hinge rotation = 0.0179 rad

Tee Support Example

- 18.8.1(c): Elongation (as per 7.8 inc. 1.5/S_p)

$$\sigma_{e\ell} = 2.6 \frac{\theta_m}{2} (d-d') \leq 0.036h_b$$

- θ_m = peak beam plastic rotation @ MCE
= 0.0179 × 1.5/0.7 = 0.0384
- Beam depth = 700mm → d-d' = 600mm
- $\sigma_{e\ell} = 2.6 \times 0.0384/2 \times 600 = 30\text{mm} < 0.036h_b$ (25mm)
= 25 mm

Tee Support Example

- Total frame dilation:
 - 4 x hinges within tee span
 - Sliding detail at one end of tee
 - All elongation from 4 hinges concentrated at one support
 - Loss of seating = $4 \times 25 \text{ mm}$
= 100 mm

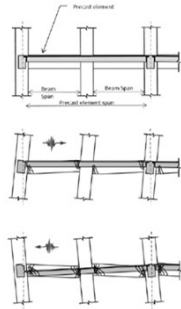

Tee Support Example

- 18.8.1(d): Rotation of the support beam
 - = peak column rotation @ MCE
x height from beam centre to ledge
 - = $0.0153 \times 1.5/0.7 \times 200$
 - = 7 mm

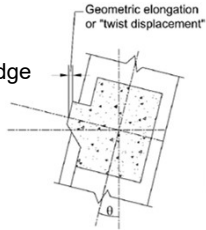

Tee Support Example

- 18.8.1(b): Spalling of support beam ledge
 - In ductile detailing length & ledge not armoured
 - spalling to centreline of long reinforcement
 - = cover (25) + stirrup (16) + $d_b/2$ (8)
 - = 49 mm

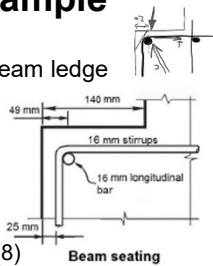

Tee Support Example

- 18.8.1(e): Spalling of end of precast floor unit
 - Unit end is not armoured
 - 30 mm unit spalling

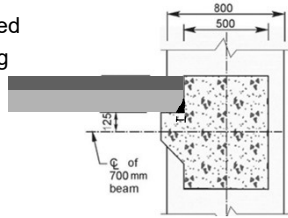

Tee Support Example

- 18.8.1(f): Shrinkage
 - = 0.5 mm/m × 10m / 2
 - = 3 mm
- 18.8.1(g): Tolerances
 - [as per NZS 3109 – see slide 2-31]
 - = 17 mm

Tee Support Example

- 18.8.1: Total with no armouring
- Min seating length = 20 + 100 + 7 + 49 + 30 + 3 + 17
= 226 mm
- Very large!

Tee Support Example

- 18.8.1: Revised total with armouring

$$\text{Min seating length} = 20 + 100 + 7 + \overset{\text{May reduce}}{\cancel{40}} + \overset{0}{\cancel{30}} + 5 + 15 = 147 \text{ mm}$$

→ More reasonable



Ch. 18 – Precast Concrete

- Lots of new commentary (esp. 18.7.4 & 18.8.1)
- Other minor changes:
 - 18.5.4: Clarified longitudinal shear limits
 - 18.5.5.2: Clarified spacing limits
 - 18.6.3: Removal of 3 storey limit to wall clauses
 - 18.8: Renumbered headings



Ch. 16 – Bearing Strength, Brackets and Corbels



Ch. 16 Changes

- **16.3** Bearing stress limits revised
- **16.4 & 16.5** Brackets and Corbels – Revised
- **16.6 & 16.7** Brackets and Corbels – New clauses
- **16.8** New section on ledges for precast floors

16.3 Bearing Strength

- **16.3.3:** $\phi = 0.75$ (consistent with strut and tie)
- **16.3.1:** Bearing stress limit reduced to $\phi 0.74f_c$
– $0.85 \rightarrow 0.74$ (due to change to ϕ)
- **Eq. 16-1** – revised due to change to ϕ
- **16.3.4:** Clarification of A_1 & A_2 (consistent with Ch. 18 precast seating)

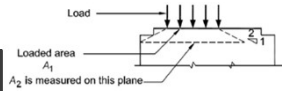

Brackets and Corbels

- **16.4.1:** Critical section for flexure

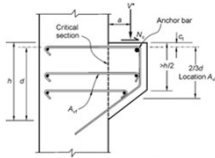

Figure C16.2 - Actions in a corbel

Wall or column = face

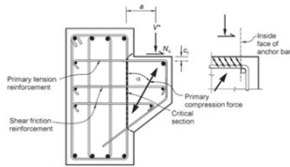

Figure C16.3 - Notation used in 16.5

Beam = centre of vertical reo close to corbel

Brackets and Corbels

- **16.4.2:** Friction

$$N_c = \mu_f \times V^* (\mu_f \geq 0.7)$$

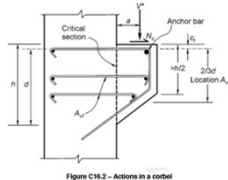
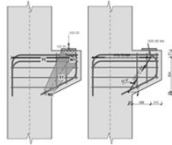

Figure C16.2 - Actions in a corbel

Brackets and Corbels

- **16.4.4:** Brackets and corbels designed by either:
 - **16.5:** Empirical design of brackets and corbels
 - **16.6:** Design requirement by strut and tie method (new)



- **16.6.7:** Beams supporting brackets and corbels
 - Must include torsional reinforcement as per 7.6.1.4

Ledges for Precast Floors

- **16.8:** New definition for ledge

16.8.1 The ledge support of precast floor units
 A ledge supporting precast concrete floor units (hollow-core, flat slabs, ribs, or tee units) is either the top of a reinforced concrete beam on to which fresh concrete shall be cast to form a composite beam, or a preformed shelf to support the floor units.

- Designed by 16.5 or 16.6
- Reinforcement:
 - Hollowcore / flat slab = distributed
 - Ribs or tees = within width or rib/web

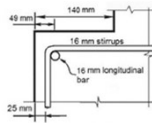

Questions?

Session 3

Materials
Durability, Fire
Couplers
Embedded Anchors
Walls

Alistair Russell / Rick Henry

3-1

**NZS 3101:2006
Amendment 3**

Session 3

NZ 3101 UPDATE

3-2

Order for the day

When	Topics		
Session 1 1:30 – 2:15	<ul style="list-style-type: none"> • Intro and Background • Displacement critical elements 		
Session 2 2:15 – 3:00	<ul style="list-style-type: none"> • Precast seating & bearing • Deformation compatibility 		
Break 3:00 – 3:30			
Session 3 3:30 – 4:15	<table style="width: 100%; border: none;"> <tr> <td style="border: none; vertical-align: top;"> <ul style="list-style-type: none"> • Materials • Durability, Fire • Couplers </td> <td style="border: none; vertical-align: top;"> <ul style="list-style-type: none"> • Embedded anchors • Walls </td> </tr> </table>	<ul style="list-style-type: none"> • Materials • Durability, Fire • Couplers 	<ul style="list-style-type: none"> • Embedded anchors • Walls
<ul style="list-style-type: none"> • Materials • Durability, Fire • Couplers 	<ul style="list-style-type: none"> • Embedded anchors • Walls 		
Session 4 4:15 – 5:00	<table style="width: 100%; border: none;"> <tr> <td style="border: none; vertical-align: top;"> <ul style="list-style-type: none"> • Walls (continued) • Curvature limits & analysis </td> <td style="border: none; vertical-align: top;"> <ul style="list-style-type: none"> • Creep & Shrinkage • Columns • Torsion </td> </tr> </table>	<ul style="list-style-type: none"> • Walls (continued) • Curvature limits & analysis 	<ul style="list-style-type: none"> • Creep & Shrinkage • Columns • Torsion
<ul style="list-style-type: none"> • Walls (continued) • Curvature limits & analysis 	<ul style="list-style-type: none"> • Creep & Shrinkage • Columns • Torsion 		

NZ 3101 UPDATE

3-3

Session 3

- Durability (3)
- Materials – Concrete E_c (5)
- Reinforcement & Couplers (8) [ϕ_y (2)]
- Embedded anchors – ETAG (17)
- Walls (11)

NZ 3101 UPDATE

3-4

Durability (chapter 3)

- Relatively minor changes
- 100 year design life for XA classification (Aggressive soil and groundwater attack) (matches NZTA bridge manual)
- Classification C – cover changes (FA/MS)
- Freeze/thaw – commentary

NZ 3101 UPDATE

3-5

Freeze/Thaw

- Previously implied all S.I. concrete should be >30 MPa
- 20 MPa driveways are obviously OK
- Clarified C3.10: need temp < -5°



NZ 3101 UPDATE

3-6

Fire (chapter 4)

- Consider walls in fire which can fall inwards and outwards
- Formerly part of B1 but not 3101:2006
- 3101 only had outwards

- New definition for **wall panel** (includes cladding panels)

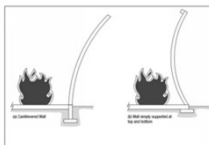

NZ 3101 UPDATE

Materials (chapter 5)

- 5.2.3 Concrete stiffness, $E_c = 4700\sqrt{f'_c} \left(\frac{\rho}{2300}\right)^{1.5}$
- 5.2.5 Modulus of rupture $f_r = 0.6\lambda\sqrt{f'_c}$
 - Simplified
 - For deflections only, 6.8 (not cracking)
- 5.2.4 Lower characteristic direct tensile strength, f_t

C5.2.4 for background, average, and upper characteristic f_t	Note also 2.3.2.3
----------------------------------------------------------------	-------------------

Materials (chapter 5)

- Min concrete strength 20 MPa
 - 17.5 for non-specific design (3604/4229)
- 5.2.10 Shrinkage } Appendix E/CE
- 5.2.11 Creep }
 - used to refer to AS 1012

Materials (chapter 5)

Reinforcement

- Class E only, (L, N)
- $\phi_{o, fy} = 1.35$ for both G300 & G500 (chapter 2)
- 500 MPa (max)
- 800 MPa***



***Still in chapter 9

3-10

Couplers (chapter 8)

- Principle of capacity design – hierarchy of failure

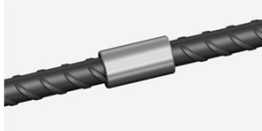

- Work in progress – but get 3101 published...

NZ 3101 UPDATE

3-11

Couplers – not critical element

- 8.6.11.1 Coupler shall be capable of developing “upper bound breaking strength”
- 8.6.11.2 $1.15-1.25 \times$ upper characteristic yield
- G500 $\rightarrow 1.25 \times 600 = 750$ MPa
G300 $\rightarrow 1.25 \times 380 = 475$ MPa

NZ 3101 UPDATE

3-12

Couplers – not critical element

- 8.6.11.1
Mode of failure = ductile yielding of the bar
AND
outside anchor or cold worked part
(= thread)

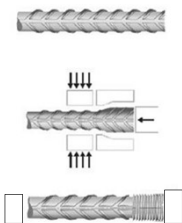

NZ 3101 UPDATE

Couplers – max force

- Aim was to align with the NZTA bridge manual
- *Maximum tensile force*
 $G500 = 840 \text{ MPa}$
 $G300 = 570 \text{ MPa}$

Work in progress

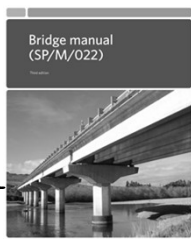

Brittle fracture resistance

- **8.6.11.4 (new)**
- Brittle fracture resistance
- “Appropriate testing” (not charpy)
 - Cold weather brittle fracture
- No cast iron couplers
 - SG iron brittle fracture prone

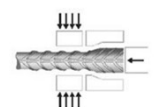

Couplers (8)

- Max tensile load – part way towards upper characteristic tensile strength
- Aim for failure away from coupler
- Brittle fracture resistance
- Stirrup splices

Stirrups

- **8.7.2.8**
- Taken as suggested in CERC
“the proportion of lapped splices
in the cover concrete at any
cross section shall be equal to
or less than 50 % of the stirrup
or tie reinforcement”

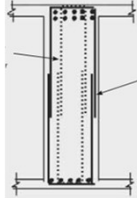

NZ 3101 UPDATE

NZS 3101 Definitions

- Brittle elements not covered (cl. 1.1.1.1)
- Precast connections:
 - “shall be designed to... develop a failure mode by yielding of steel reinforcement or other non brittle mechanism” (cl. 18.6.5)
- Fixings:
 - “Fixings may be designed for ductility” (cl. 17.6.5)
 - “suppress a brittle concrete pull-out failure” (cl. C17.6.5)

NZ 3101 UPDATE

Embedded Anchors (17)

- ~~Fixings Anchors~~
- **Post-installed anchors**
 - ACI 318 Appendix D
- “shall pass the prequalification testing ...in ETAG 001, Annex E”
- “be designed to EOTA TR045”
- European Technical Approval Guidelines



NZ 3101 UPDATE

Corrections (17)

- Strength reduction factors for anchors:
 $\phi = 0.65$ (shear)
 $\phi = 0.75$ (tension)
- Concrete breakout/side-face blowout
 $\phi = 0.65$ (tension)

Inserts in Precast Panels

- Shallow embedded inserts for panel-foundation connections should be avoided
 – Recent testing showed joint failure

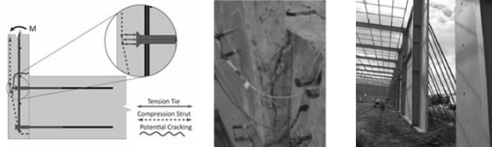

Inserts in Precast Panels

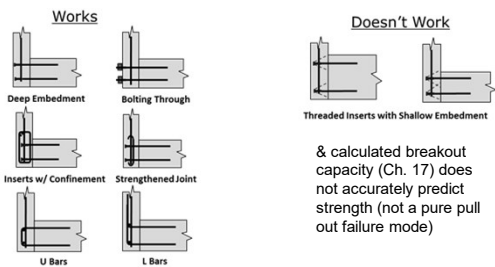

3-22

Walls (chapter 11)

- Walls featured in the CERC recommendations
- Walls in modern buildings in Christchurch – detailing could improve performance



NZ 3101 UPDATE

3-23

Walls

- New notation – t_w , not b_w
- Singly reinforced walls – $\mu = 1.25$ & $\phi = 0.7$
- Min vertical reinforcement, p_{min}
- Transverse reo for confinement and anti-buckling
- Horizontal reinforcement anchorage
- Axial load, slenderness & coupled walls

NZ 3101 UPDATE

3-24

Why Walls?



NZ 3101 UPDATE

3-25

Why Walls?

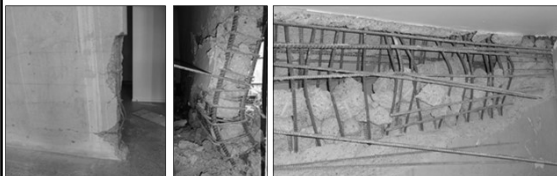

NZ 3101 UPDATE

3-26

Lack of Distributed Flexural Cracking



NZ 3101 UPDATE

3-27

Minimum Vertical Reinforcement

Ductile & Limited Ductile Walls

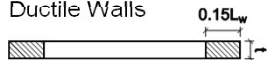

Nominally ductile

- Existing ok
- $\rho_n \rightarrow \rho_l$

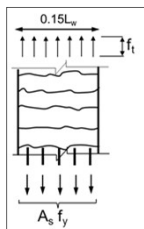

NZ 3101 UPDATE

3-28

Ductile & Limited Ductile Walls

Minimum end zone reinforcement (ρ_w) ensures close spacing of cracks & spread of yielding.

Minimum central region reinforcement (ρ_l or $0.3\rho_w$) ensures cracks extend through the tension zone & provides shear resistance.

$\rho_w = \frac{\sqrt{f'_c}}{2f_y}$ $\approx 2 \times$ existing

$\rho_c = \frac{\sqrt{f'_c}}{4f_y}$ Existing minimum

$\rho_w = \frac{\sqrt{f'_c}}{2f_y}$ $\approx 2 \times$ existing

NZ 3101 UPDATE

3-29

Minimum Vertical Reinforcement

$$p_{\ell, \min} = \frac{1.2 \times 0.85 \times 0.52 \sqrt{1.2 \times 1.1 \times f'_c}}{1.1 \times 1.08 \times f_y}$$

$$p_{\ell, \min} = \frac{0.5 \sqrt{f'_c}}{f_y} \equiv \frac{\sqrt{f'_c}}{2f_y}$$

NZ 3101 UPDATE

3-30

Minimum Vertical Reinforcement

- 1.2 – tensile strength increase of concrete due to dynamic loading
- 0.85 – drying shrinkage
- 0.52 – mean tensile strength to the upper characteristic (95%ile)
- 1.2 – average *target* compressive strength in NZS3104 to specified
- 1.1 – increase in concrete compressive strength due to age
- 1.1 – tensile strength increase of reinforcement due to dynamic loading
- 1.08 – lower characteristic (specified) strength of reinforcement to the mean strength

NZ 3101 UPDATE

End Zones in Ductile Walls

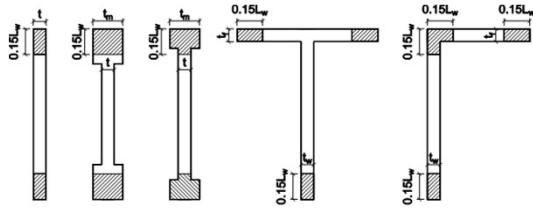

Minimum Vertical Reinforcement

11.4.4.2 Minimum area of reinforcement

In the end zone of the wall, which is defined as having a length extending a distance of 15 % of the wall length in the direction of loading from the extreme tension fibre, and a width equal to the thickness of the end of the wall at the location being considered, the ratio of the area of vertical reinforcement in the end zone to the area of the end zone, ρ_{ez} , shall be equal to or greater than $\frac{\sqrt{f_c}}{2f_y}$.

In the portion of the wall between end zones, the ratio of the area of vertical reinforcement to unit cross section area, ρ_v , shall be equal to or greater than $\frac{\sqrt{f_c}}{4f_y}$, and greater than $0.3 \rho_{ez}(f_{y,ext}/f_{y,web})$.

Singly Reinforced Walls

- Lack of robustness
 - Aim for no significant damage while maintaining lateral stability
- New provisions (in-plane only)
 - $\mu = 1.25$, nominally ductile only (normally done) AND $\phi = 0.7$
 - Essentially elastic behaviour

SESOC Interim Guidance



Singly Reinforced Walls

- Lack of robustness
 - Not significant damage while maintaining lateral stability
- New provisions
 - $\mu = 1.25$, nominally ductile only (normally done) AND $\phi = 0.7$
 - Essentially elastic behaviour

$$\phi = 0.85 \times 0.8 \approx 0.7$$

0.8 = ratio of M_y/M_u
Wall behaves elastically

SESOC Interim Guidance

Singly Reinforced Walls

11.3.1.5 Singly reinforced walls

Buildings where singly reinforced walls form part of the primary lateral load resisting system shall be designed for nominally ductile actions, with the appropriate strength reduction factor defined in 2.3.2.2. The area of vertical reinforcement for singly reinforced walls shall be equal to or less than the limit given in 11.3.12.3(a).

2.3.2.2 Strength reduction factors, ultimate limit state

The strength reduction factor, ϕ , shall be as follows:

- (a) For actions which have been derived from overstrengths of elements in accordance with the principles of capacity design (see 2.6.5) 1.00
- (b) Anchorage and strength development 1.00
- (c) Flexure with or without axial tension or compression 0.85
- (d) Flexure and shear in singly reinforced walls for in-plane actions only 0.70

Singly Reinforced Walls

Table 2.5
 $\mu = 1.25$

Table 2.5 – Maximum available structural ductility factor, μ , to be assumed for the ultimate limit state

Type of structure	Reinforced concrete	Prestressed concrete with bonded non-prestressed reinforcement
1. Nominally ductile structures In-plane action of singly reinforced walls	1.25	1.25
2. Structures of limited ductility		
(a) Moment resisting frame	3	3
(b) Walls	3	3
(c) Cantilever face loaded walls (single storey only)	2	2
3. Ductile structures		
(a) Moment resisting frame	6	5
(b) Walls:		
(i) Two or more cantilevered	5	5
(ii) Two or more coupled	6	6
(iii) Single cantilever	4	4

NOTE – The structural ductility of all members may be limited by the maximum permissible material strains.

3-37

Horizontal Reinforcement Anchorage

- Singly reinforced walls (essentially elastic → OK)
- Doubly reinforced walls

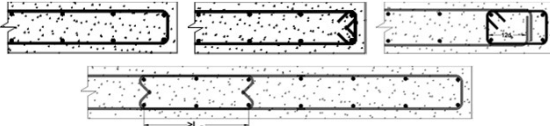

SESOC Interim Guidance

NZ 3101 UPDATE

3-38

Horizontal Reinforcement Anchorage

11.3.12.5 Anchorage of shear reinforcement at wall ends
 For walls, excluding singly reinforced walls, the horizontal reinforcement shall be anchored at the end of the wall using one of the methods outlined in (a) to (c):

- (a) Horizontal reinforcement shall be bent around both of the corner end bars to form a continuous U-shaped bar; bend diameters shall comply with 8.4.2;

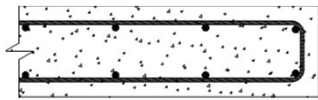

NZ 3101 UPDATE

3-39

Horizontal Reinforcement Anchorage

11.3.12.5 Anchorage of shear reinforcement at wall ends
 For walls, excluding singly reinforced walls, the horizontal reinforcement shall be anchored at the end of the wall using one of the methods outlined in (a) to (c):

- (b) Horizontal reinforcement shall be bent around a corner bar at the ends of the wall with a 135° or 180° hook. The two corner bars at the end of the wall shall be linked transversely with the tie having a cross-sectional area and spacing equal to that of the horizontal bars. These links shall be bent around the vertical bars with 135° hooks complying with 8.6.10;

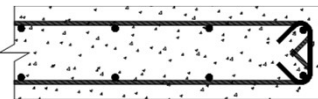

NZ 3101 UPDATE

3-40

Horizontal Reinforcement Anchorage

11.3.12.5 Anchorage of shear reinforcement at wall ends

For walls, excluding singly reinforced walls, the horizontal reinforcement shall be anchored at the end of the wall using one of the methods outlined in (a) to (c):

- (c) Horizontal reinforcement shall be anchored as close as practical to the end of the wall with 90° or semicircular hooks, as per 8.6.10, and these hooks shall be terminated within a cage that comprises horizontal stirrups enclosing at least four vertical bars at the end of the wall. These four vertical bars shall comprise the two corner bars and at least the next group of vertical bars along the horizontal

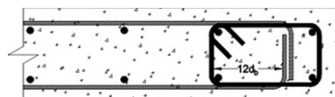

NZ 3101 UPDATE

3-41

Horizontal Reinforcement Anchorage

$$\frac{A_s}{s} \text{ (stirrups)} = \frac{A_s}{s} \text{ (horizontal bars)}$$

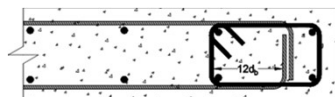

NZ 3101 UPDATE

3-42

Wall Intersections (11.3.12.6)

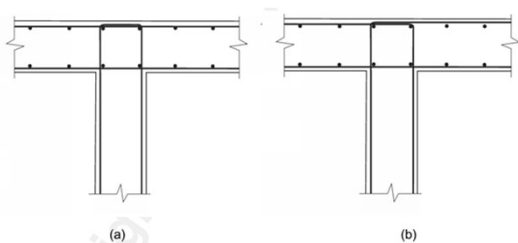
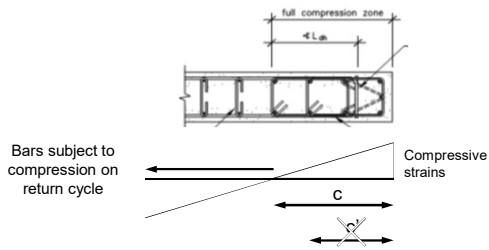

Figure C11.1F – Intersection of bars at T-shaped wall

NZ 3101 UPDATE

3-43

Plastic Hinge Detailing



NZ 3101 UPDATE

3-44

Confinement

11.4.5.5

Confinement requirements in plastic region

(b) The length of the confined region of the compressed wall section c' shall be equal to or greater than c

NZ 3101 UPDATE

3-45

Plastic Hinge Detailing

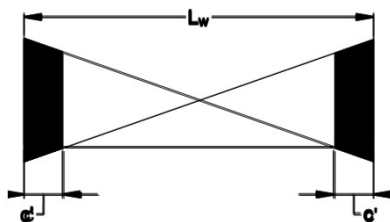

NZ 3101 UPDATE

3-46

Plastic Hinge Detailing

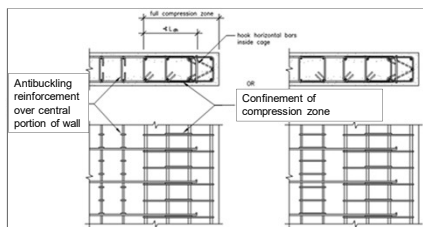

NZ 3101 UPDATE

3-47

Transverse Reo Central Region

11.4.5.3

In central region, when triggered by:

- High shear
- Low cover
- Large curvatures (large tensile reinforcement strains)

Generally high probability of spalling

NZ 3101 UPDATE

3-48

Transverse Reo Central Region

11.4.5.2 – compression region of wall
Antibuckling (not new)

11.4.5.3 – central region of wall
Reinforcement detailing as per



NZ 3101 UPDATE

Walls Design Guide



- Wall design worked example
- Shear walls
- Coupled walls
- Seminars early 2018

Walls as Columns

- **2.6.5.8** Concurrency and Capacity Design
 - Generally – if out-of-plane thickness is “small” → Wall
 - If not → Column
- **11.2.3** Axial load limits
 - If limits are exceeded, design as a column

Global Wall Buckling

- Instability & buckling are complicated
- Wall elongation & axial loads – difficult
- Slenderness limits
- Research ongoing



Key Recommendations

✓ Peak/Design drift	✓ Commentary on elongation
✓ Stairs and ramps should sustain 1.5 x peak drift	✓ Elongation at corners of buildings
✓ Single cracks in structural walls	✓ Axial compression in beams due to floor restraint
✓ Ductile wall detailing (transverse reinforcement)	✓ Low friction bearing strips for TT units
✓ Axial load ratio on walls (+ research)	✓ Stirrups lapped in cover concrete <50% of stirrup
✓ Magnitude of elongation to be considered in design	

NZS 3101:2006 Amendment 3

Alistair Russell
Rick Henry

Session 4

Walls (continued)
Curvature Limits & Analysis
Creep & Shrinkage
Columns
Torsion

Alistair Russell / Rick Henry

NZS 3101:2006 Amendment 3

Session 4

Session 4

- High axial load & Coupled walls (Ch. 11)
- Stiffness estimates (Ch. 6)
- Ductility factors & Material strains (Ch. 2)
- Loose ends (Ch. 7, 9, 10, 13, 15)
- Appendix E

Walls – Axial load limits

- Previously no axial load limit in NZS 3101
- Uncertainty around behaviour of walls with high axial loads
- CERC recommendation

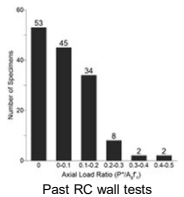

Walls – Axial load limits

11.3.1.6 Maximum axial actions

For walls the ultimate axial load in compression, N^* , shall be less than $0.3\phi f_c A_g$.

11.4.1.1 Maximum axial actions for ductile walls

For ductile and limited ductile walls the maximum axial load in potential plastic regions (N_c) shall not exceed $N_c \leq 0.3A_g f_c$.

11.2.3 Axial load limit on walls

When the limits in 11.3.1.6 and 11.4.1.1 are exceeded, the design of a wall shall proceed according to the provisions of Section 10.

11.3.7 Walls with high axial loads

The ratio of effective height to thickness ($k_e h_e / t$) shall be equal to or less than 20 where $N^* > 0.2\phi f_c A_g$.

Recent Tests – High axial load

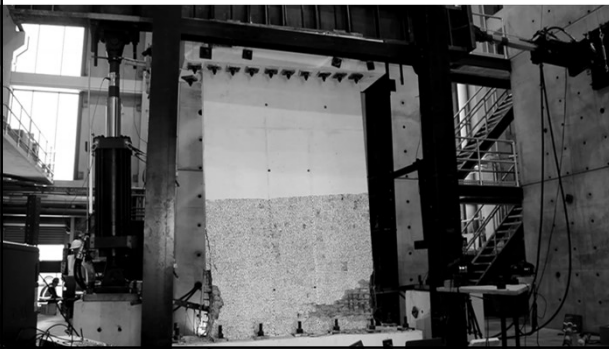

Walls – Axial load limits

- Be careful with high ductility demands
- Initial tests indicate that at $0.3A_g f_c$:
 - Drift capacity < 1.5%
 - Curvature ductility ~50% of NZS 3101 material strain limit (K_d)

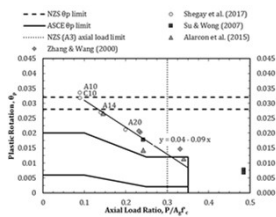

Coupled Walls

- No specific clauses previously in Ch. 11 [coupling beams covered in Ch. 9]
- CERC recommendation regarding overstrength

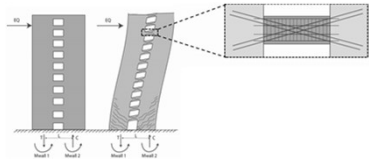

Coupled Walls

- Coupling beam elongation/deformation restrained by floors and wall piers

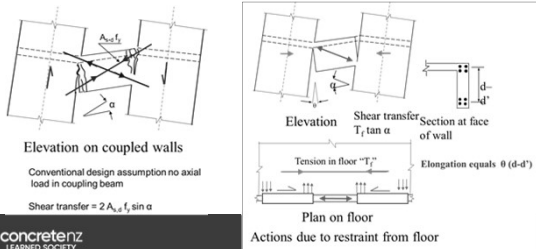

Coupled Walls

- Coupling beam overstrength can alter inelastic mechanism:
 - Reduce ductility
 - Wall pier shear
 - Wall pier axial loads

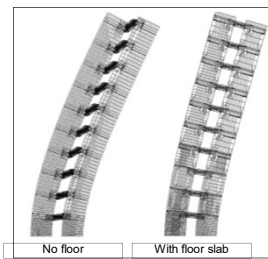

Coupled Walls

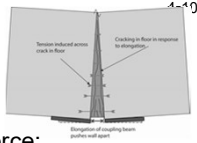

- 11.4.9.2: Coupling beam axial force:

$$N_{o,c} = \phi_o f_y A_{s,f} \quad \text{Eq. 11-31}$$

- $A_{s,f}$ = area of reo. parallel to coupled wall, within a width that is the smaller of:
 - Half span to next line of support (beam/wall)
 - 4 times the depth of coupling beam (h_b)
- Precast floor units parallel to wall = strength of units as per 9.4.1.6.2



Coupling Beam - Detailing

- 11.4.9.4 (a) – Confined diagonal bar groups

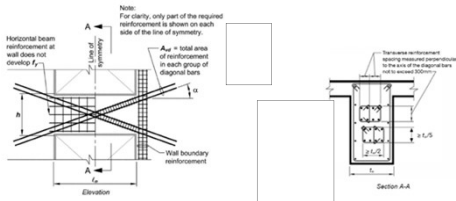

Figures C11.7, C11.8 and C11.9 are authorised adaptations of Figure R21.9.7(a)(b) Coupling Beams with Diagonally Oriented Reinforcement from the American Concrete Institute's ACI 318-05 Building Code Requirements for Structural Concrete and Commentary. Reproduced with permission from the American Concrete Institute. Figures C11.7, C11.8 and C11.9 are authorised adaptations of Figure R21.9.7(a)(b) Coupling Beams with Diagonally Oriented Reinforcement from the American Concrete Institute's ACI 318-05 Building Code Requirements for Structural Concrete and Commentary. Reproduced with permission from the American Concrete Institute.



NZ 3101 UPDATE

Coupling Beam - Detailing

- 11.4.9.4 (b) – Confined beam section

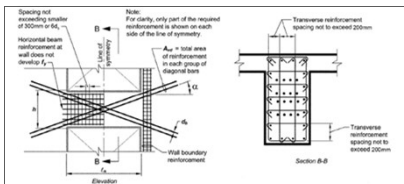

Figures C11.7, C11.8 and C11.9 are authorised adaptations of Figure R21.9.7(a)(b) Coupling Beams with Diagonally Oriented Reinforcement from the American Concrete Institute's ACI 318-05 Building Code Requirements for Structural Concrete and Commentary. Reproduced with permission from the American Concrete Institute.



NZ 3101 UPDATE

Structural Ductility Factors

- Revision to Table 2.5:
 - Removal of β factors for walls (covered by material strain limits)

Table 2.5 – Maximum available structural ductility factor, μ , to be assumed for the ultimate limit state

Type of structure	Reinforced concrete	Prestressed concrete with bonded non-prestressed reinforcement
1. Nominally ductile structures In-plane action of singly reinforced walls	1.25	1.25
2. Structures of limited ductility		
(a) Moment resisting frame	3	3
(b) Walls	3	3
(c) Cantilever face loaded walls (single storey only)	2	2
3. Ductile structures		
(a) Moment resisting frame	6	5
(b) Walls		
(i) Two or more cantilevered	6	5
(ii) Two or more coupled	6	6
(iii) Single cantilever	4	4

NOTE: The structural ductility of all members may be limited by the maximum permissible material strains.

Material Strain Limits

- **Reminder:**
 - Category of potential plastic region is based on material strains (deformation demands) (2.6.1.3)
 - Can differ from global structural ductility

- Reorganised for clarity
- Correction to equation in 2.6.1.3.2(b)(ii)



Material Strain Limits

- **2.6.1.3.4 (c):** Nominally ductile beams /columns
 - Group i:
 - Flexure controlled + T&C reo. + bar buckling restraint
 - Some ductility ($K_d = 3$)
 - Group ii
 - Not meeting criteria of i
 - No reliable ductility ($K_d \leq 1 \rightarrow$ depends on shear strength)
- **2.6.1.3.4 (e):** Squat walls – New limits

Material Strain Limits

- Nominally ductile walls (Table 2.4):
 - Doubly reinforced $K_d = 4$
 - Singly reinforced $K_d = 0.8$ (essentially elastic @ MCE)
- No changes to other K_d limits in Table 2.4



Ch. 7 – Shear and Torsion

- **7.5.2:** Maximum nominal shear stress, v_{max}
 - Beams: $0.2f_c$ or 10 MPa
 - Walls: $0.16f_c$ or 6 MPa
 - Columns: $0.2f_c$ or 6 MPa
- **7.6:** Updates to several provisions for torsion
 - Eq. 7-6(a)
 - Eq. 7-10 – error in published version

$$T_{r,min} = 0.30 A_{cv} f_c \lambda \sqrt{f_c} \sqrt{1 + \frac{N'}{0.33 A_{cv} \lambda \sqrt{f_c}}}$$

Ch. 7 – Shear-friction

- Only relates to potential sliding at an interface
 - Does not prevent diagonal tension (shear) or compression failure
 - Preferable to use strut and tie
- μ_f (avoid confusion with ductility factor)
- **7.7.4.3:** Concrete interface not roughened $\rightarrow \mu_f = 0$
- **7.7.5:** Max shear stress for shear friction - *New*

Ch. 9 - Beams

- **9.3.9.3.3:** Max nominal shear stress $0.2f_c$ or 10 MPa



- **9.3.9.3.4:** Clarification of v_c and k_d (depth factor) for beams with depth 200-400mm

Ch. 9 - Beams

- **9.3.9.4.13:** Revised criteria for members with no shear reinforcement
 - Includes previous B1/VM1 clarification on precast member depth (300 mm)
 - Strength of members with no shear reinforcement is more variable → $V^* < 0.5\phi V_c$



Ch. 10 - Columns

- **10.2** – Requirements for piers shall be the same as those for columns
 - All instances of “and pier” deleted
- Correction to **Eq. 10-34**

$$\cancel{v_c = 3v_b \left[\frac{N_o^*}{A_g f_c} - 0.1 \right] \geq 0.0} \rightarrow v_c = 3v_b \left[\frac{N_o^*}{A_g f_c} - 0.1 \right] \geq 0.0$$

Ch. 13 - Diaphragms

- 13.3.1: Seismic actions as per NZS 1170.5
- 13.3.2: Design shall be based on strut and tie (Appendix A)

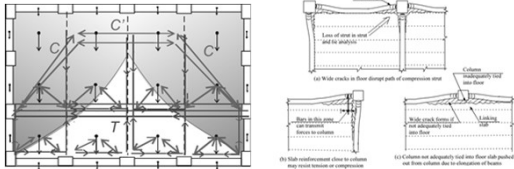

Ch. 15 - Joints

- 15.3.6.2: Anchorage of beam reo in external joint
 - As per 8.6.12.6:
 - Close as possible to opposite face of column
 - $>L_{dh}$ and $0.75h_c$
 - Joint shear reo that encloses hook and column long reo

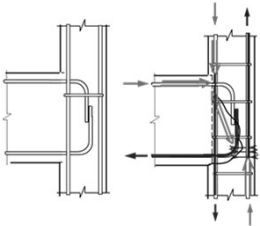

Appendix E Shrinkage and Creep

- Previously only commentary
 - Appendix CE (but no Appendix E content!)
 - General guidance on shrinkage and creep, but no information on typical NZ values
- Appendix E – New
 - Modified from Australian practice (AS 3600-2009)
 - Based on AS1012.13 shrinkage test
 - Tables of typical NZ shrinkage values for this test

Questions?

Appendix A

NZS 3101:2006 Amendment 3

List of Key Changes

Reference

Amendment 3 to NZS 3101

*Dene Cook, Richard Fenwick, Alistair Russell
(2014 NZCIC)*

Design of RC Walls Post the Canterbury Earthquakes

*Alistair Russell, Rick Henry, Richard Fenwick
(2015 NZCIC)*



AMENDMENT 3 TO NZS3101

DENE COOK¹, RICHARD FENWICK², ALISTAIR RUSSELL³

¹ Fletcher Building Infrastructure Division

² Adjunct Professor University of Canterbury

³ Cement and Concrete Association

SUMMARY

NZ Engineers have a proud tradition of developing practical and pragmatic design solutions from the lessons learnt from research and seismic events. The current proposed amendment of NZS3101 continues to advance the art and science of detailing reinforced concrete structures for appropriate behaviour, particularly in earthquakes, largely as a result of lesson learnt from the Canterbury earthquakes.

Generally reinforced concrete buildings performed within the performance expectation of the Building Code in the Canterbury Earthquake sequence. However, analysis of the damaged buildings highlighted a number of aspects of building performance that were not adequately covered in current design standards. These aspects included;

- Structural walls that exhibited brittle characteristics due to inadequate longitudinal reinforcement, which resulted in isolated cracks forming in the walls and with reinforcement failing due to the high strains at these cracks.
- A number of structural walls failed in what appeared to be a mixture of flexural and shear modes possibly associated with bi-axial loading.
- Damage and unexpected behaviour of some structural elements due to elongation of plastic hinge zones. While engineers have been aware of potential problems arising from elongation for many years little attention has been given to the adverse effects of this action.
- Many stairs in multi-storey buildings collapsed due to inadequate allowance for inter-storey drift and elongation.
- In a number of cases the increase in flexibility of structural elements due to cracking was over-estimated resulting in high estimates of the fundamental period and the corresponding under-estimate of the required seismic strengths.

These issues are addressed in this amendment. In addition some further changes have been made to correct errors in the current standard, simplify design criteria, and to incorporate findings from recent research.

AMENDMENT 3 TO NZS3101

The following paper provides the reasoning behind the more significant changes to NZS3101. Excluded from this paper are the predominantly editorial changes.

Chapter 2 Design Procedures

Chapter 2 effectively links the Standard to the loadings suite AS/NZS1170. It sets out the basic concepts which are used throughout the document and it gives a guide to where different design aspects are located. There are a number of proposed changes to this chapter as outlined below.

2.2.3 Design for robustness, durability and fire resistance

The clause has been modified to require stairs and ramps to be designed to be serviceable under the maximum considered earthquake, and for external cladding panels not to collapse. For concrete structures the maximum considered earthquake is taken as 50 percent greater than the ultimate limit state design earthquake. The requirements are more fully explained in section 2.6.10.4 (a new clause). This clause specifies that the peak storey drift is used in assessing imposed displacements together with any additional deformation arising from elongation, rotation of the supports or fixing for cladding panels. The design inter-storey drift found from NZS1170.5 is a value that may be expected to occur several times during a design level earthquake (see NZS1170.5, C4.4). The peak value is taken as equal to the design drift divided by the S_p factor. Assistance on the estimation of elongation effects has been provided in a new section in chapter 7.

Section 18.7.4 provides more detailed information on how supports for precast flooring units can be detailed to accommodate deformations arising from peak inter-storey drifts, elongation and twisting of supporting structure. **Section 18.8 also.**

2.3.2.2 Strength reduction factors

The capacity reduction factor for singly reinforced walls subject to in plane actions has been reduced to 0.7. This is coupled with a requirement in 11.3.1.4 that singly reinforced walls that are part of the primary lateral load resisting system are to be designed as nominally ductile members. With this revised strength reduction factor a wall designed by standard ultimate strength theory will respond without significant yielding of reinforcement in an ultimate limit state level earthquake and with only limited inelastic deformation in an MCE level earthquake. The change in strength reduction factor was made due to concerns about the stability of these thin walls when they sustained inelastic deformation simultaneously with out of plane seismic forces. Although this appears a significant change, it is understood that most designers were already designing thin singly reinforced walls for near elastic actions.

The strength reduction factor for tension in concrete has been reduced from 0.6 to 0.3. This change was made due to the difficulty of assessing tensile stresses induced by self-strain actions such as differential temperature, differential creep and shrinkage and heat of hydration. No allowance for tensile strength of concrete is permitted for flexural actions. Clause 2.3.2.3 indicates that where reliance is placed on the tensile strength of concrete in a number of situations, such as in design for shear, the appropriate magnitude of tensile strength are given in the appropriate clauses. Where such a value is not given the strength reduction factor of 0.3 is to be used.

2.4.4 Crack Control

This section covers criteria to limit the widths of flexural cracks in the serviceability limit state but excluding load combinations that contain seismic or wind forces.

Maximum crack widths for bridge superstructures, which previously were in the Bridge Manual, have been added to the Standard in clause 2.4.4.2, while the corresponding recommendations for buildings remain in the commentary.

The crack control criteria given in 2.4.4.3 to 2.4.4.6 have been modified in the light of recent research in which crack widths in test beams were measured and compared with calculated reinforcement stresses. There is a problem with the design criteria developed from these tests in that the influence of shrinkage of the concrete was not monitored or considered. The shrinkage levels were probably small as test beams are generally tested at an early age before most of the shrinkage would have developed.

When concrete in a reinforced member shrinks the reinforcement is subjected to compression and tensile stresses are induced in the concrete. For example in a reinforced concrete element with, 1% reinforcement, a free concrete shrinkage is 600×10^{-6} , an elastic modulus of 30,000MPa and the creep factor is 2.5, the shrinkage induced compression stress in the reinforcement is close to 100MPa and the associated tensile stress in the concrete is of approximately 1MPa. If after the shrinkage has developed the member is loaded until the concrete cracks, and then the load is then removed, the stress in both the concrete and the reinforcement decrease to zero at the crack. However, the crack does not fully close, as the stress in the reinforcement decreases in the vicinity of the crack from 100MPa in compression to zero at the crack. This decrease in this stress (100 to 0MPa) causes the bar to extend and prop open the crack. If the reinforcement stress is subsequently increased to 250MPa due to a serviceability load combination the crack width corresponds to a stress change of $100 + 250$ MPa. Ignoring the influence of shrinkage in this case is likely to result in a 40% under-estimate of the average crack width.

The design criteria in clauses 2.4.4.4 and 2.4.4.5 are a simple means of controlling crack widths by limiting the spacing of reinforcement in the flexural tension zones of members. This approach neglects the adverse effect of shrinkage of concrete on crack widths. Generally, where these criteria are followed the maximum crack widths should not exceed 0.5mm. However, where the average free concrete shrinkage in a member exceeds 400×10^{-6} the crack widths may be significantly under-estimated. It should be noted that the free shrinkage value is assessed allowing for the size of the member and environment as set out in Appendix E and CE. Where it is important not to exceed specified crack widths the approach given in 2.4.4.6 should be followed, as this method makes some allowance for the adverse effects of shrinkage on crack widths. With this approach the theoretical stress change due to shrinkage has been halved on the basis that, some shrinkage would have occurred in the test beams from which the criteria was derived, and once the cracks form the compression stresses induced by further shrinkage are smaller than in a corresponding level in an uncracked member.

Clause 2.4.4.5 contains criteria for controlling crack widths in the flexural tension zones on the sides of slabs and beams where the depth exceeds a metre. The only change in this clause was to replace the criteria for the amount of skin reinforcement given (d) in the current standard with a criterion based on there being a sufficient reinforcement to induce a tensile stress close to $0.25 \sqrt{f'_c}$ in the concrete surrounding the bars. It is believed that this level of reinforcement is sufficient to ensure a number of small cracks (secondary cracks) will develop instead of one wide crack. The criteria given in (a) to (d) control the widths near the surface of the member for serviceability limit state conditions. In wide members the crack widths in the mid regions may be significantly greater than those at the surface, which can have adverse effects for shear resistance and the ductility of members subjected to inelastic deformation. Consequently, where it is important that ductile behaviour is obtained, for example in structural walls, different criteria need to be applied (see chapter 11).

2.6.1.3.2 Material strain limits in plastic hinges

The clause has been reworded to aid clarity. A typographical error has been corrected in the equations in 2.6.1.3.2(b)(ii) to make the same as NZS1170.5.

2.6.1.3.3 Effective plastic region lengths

The section has been rearranged to combine the various rules for determining the effective plastic hinge length used to calculate curvatures into a single inequality. The k_p factor, which is given in Equation A, has been introduced to allow for an increase in effective plastic hinge length when the ratio of effective depth to overall depth, d/h , is less than 0.75. This adjustment makes an allowance for greater proportional contribution to flexural rotation that occurs due to the close location of the reinforcement to the compression face of the member, and to the increase in rotation that arises from the extension of reinforcement in its development length.

2.6.1.3.4 Material strain limits for flexural plastic hinge regions and shear strain for diagonally reinforced coupling beams

The section has been modified so that the methodology for checking curvatures in plastic hinge zones is the same for both nominally ductile and ductile structures. Table 2.4 has been modified to reflect this. Also the K_v factor for single reinforced walls has been reduced to reflect the desire for these walls to be proportioned so that they respond without yielding of reinforcement for ultimate limit state actions.

Rather than include values for unidirectional hinges in Table 2.4, the methodology now is to cover these by allowing a doubling of the tabled values (2.6.1.3.4(b))

Section (c) now covers the requirements for nominal ductile members. They are subdivided into two categories; group (i) where the strength is limited by flexure and certain detailing requirements have been addressed, or group (ii) where these requirements are not satisfied. Potential plastic regions are not permitted in group (ii) nominally ductile members.

2.6.2.2.2 Lower S_p may be used when detailing requirements are met

The words “that comply with the requirements of 2.6.6.1(a)” have been inserted into the clause to make it clear that a S_p of 0.7 can be used for nominally ductile structures when detailing in the potential plastic hinge regions satisfies the requirements for limited ductile plastic regions **and** an acceptable side sway mechanism will form in preference to other less ductile failure mechanisms.

2.6.2.3.2 ULS

Table 2.5 has been modified by removing β_a modification factors for walls as its function has been replaced by the material strain limits.

2.6.5.5 Likely maximum material strengths

The overstrength factor for both Grade 300 and 500 reinforcement has been set at 1.35 as recent research shows that this is appropriate.

2.6.5.10 elongation in plastic regions

Though elongation of plastic hinges has been recognised for over 35 years very little allowance has been made for the adverse effects of this deformation in previous structural concrete standards. The Canterbury Earthquakes highlighted the importance of elongation and clauses have been introduced into the Standard to address the adverse effects related this action. A new section 7.8 has also been added to the standard to enable the magnitude of elongation that may arise in different situations to be determined. The clause 2.6.5.10 requires allowance to be made for the deformation arising from elongation, and where

appropriate the actions induced by this elongation, in the following situations;

- (a) the support of stairs and ramps which connect different levels in a building, 2.6.10.4 and 18.7.6,
- (b) The support of cladding panels, section 17
- (c) the support of precast floor elements, 18.7.4
- (d) coupling beams in coupled structural walls, 11.4.10
- (e) axial forces induced in structural walls, 11.4.1.
- (f) transfer of forces between floors with precast units and lateral force resisting elements, section 13

2.6.8.3 Coupled walls

The clause has been modified to include consideration of the clamping forces provided by the floors and the foundation beams as coupled walls are subjected to sway. Guidance on how to evaluate these clamping forces is provided in 11.4,10

2.6.10.4 Stairs and ramps.

This new clause has been added to provide a high degree of confidence that egress routes will be available for evacuations after a large earthquake. Stairs and ramps are to be designed to be functional after sustaining actions associated with an MCE earthquake.

Chapter 3 Durability

The changes to this chapter are relatively minor. Table 3.4 has been modified to also include guidance for a specified intended life of 100 years. The requirements matching those provided in the NZTA Bridge manual.

The cover requirements in tables 3.6 and 3.7 for FA and MS for both the 50 and 100 year specified life have been slightly modified for exposure classification C. This reflects the latest results from ongoing chloride ingress monitoring of exposure blocks.

Clause 3.14.1.2 has been reworded to aid interpretation, and clause 3.14.1.3 has been modified to make it clear that XRF testing needs calibration.

Commentary clause C3.10 has been modified as previously the commentary gave information which implied that in the South Island concrete strengths greater than 30MPa would always be required to prevent freeze thaw. The satisfactory performance of 20MPa driveway obviously refutes this. The commentary has been amended to make clear that temperatures less than -5°C are required to cause freezing of water in the pores of concrete, and Table C3.1 has been modified to show the number of times that temperatures are likely fall below -5°C in various centres.

Chapter 4 Fire Resistance

The changes to this section are limited to section 4.8. When NZS3101:2006 was cited and became a verification method under B1 of the Building Compliance documents, section 4.8 was modified by MBIE to consider walls which could fail both inwards or outwards (clause 4.8 only mentions outwards).

The amendment of 4.8 integrates the modification of B1 into the clause and rewords the clause to aid understanding. Clause 4.8.3 has also been modified to make it clear that the design requirements provided in (a) to (c) relate to a building where a non-enclosed fire (warehouse) will occur.

Chapter 5 Materials

Again changes are relatively minor and predominantly to assist interpretation. The minimum concrete strength in clause 5.2.1 has been reduced from 25 to 20MPa to remove a conflict with Chapter 3. The equation for the modulus of elasticity has been simplified in clause 5.2.3. Clauses 5.2.10 and 5.2.11 have been modified by referencing appendix E where new information is provided on creep and shrinkage.

Clause 5.3.2.3 has been modified to mandate the use of Class E reinforcement and clause 5.3.2.4 which used to provide conditions on the use of class N reinforcing has been deleted.

Chapter 6 Methods of Analysis

Clause 6.3.7.1.1 has been modified to note that the stiffness considered in analysis should include the consideration of tension stiffening, ie the increase in member stiffness between cracks. The existing clause contained an editorial error implying that tension stiffening should be neglected. The title to clause 6.3.7.2 has been modified to make it clear that it also applies to nominally ductile structures. 6.4.2 has been modified to mention the consideration of hinge elongation as a nonlinear material effect.

In 6.8.3 a third option for calculating the deflections has been added. This method gives a better estimate of the deflected shape of a reinforced concrete member that sustains both positive and negative bending moments and where the reinforcement proportions vary along the member.

6.9.1 Linear elastic analysis

The clause has been modified to advise designers that realistic estimates are required of the extent of cracking when determining seismic actions. To obtain realistic predictions of periods of vibration and of lateral deflections in seismic load cases, allowance must be made for the effects of cracking on member stiffness. This is particularly important in modelling structural walls. Unless structural analysis indicates that flexural cracking is likely to occur in a structural member in the storey being considered, either gross section properties, or transformed section properties assuming concrete does not crack, should be used. In a number of buildings examined in the Christchurch it was found that section properties for walls had been reduced to 40% and/or 25% of gross section properties to allow for flexural cracking. However, analysis showed that very limited cracking would have been anticipated under a design ULS earthquake and consequently the fundamental periods were over-estimated and the design forces very significantly under-estimated. This highlights the need to make realistic allowances for stiffness reduction due to flexural cracking. For the purpose of assessment of flexural cracking the critical tensile strength should be taken as $0.55\sqrt{1.2f'_c}$. The coefficient of 1.2 makes an allowance for the likely long term gain in tensile strength with time. Where this level of tensile stress is not exceeded section properties should be based on gross section values or transformed section properties neglecting cracking in concrete.

The commentary to clause 6.9.1 has been extensively modified to assist designers. A revised Table C6.5 has been developed to give more refined estimates for member stiffness's.

6.9.1.5 Redistribution of moments and shear forces.

6.9.1.5 has been modified to remove restrictions on the amount of redistribution that can occur when considering seismic actions. The 2006 version of NZS3101 includes the requirements to calculate the expected inelastic curvatures in critical plastic hinges and check that they are below stated limits. This check removes the need to place limitations on the amount of redistribution. However, it is important to address the consequences of redistribution of ultimate limit state actions on the serviceability limit state. This consideration will often place some restrictions on the amount of redistribution which is achievable.

Chapter 7 Flexure, Shear, Torsion and Elongation

This chapter has been modified to correct some minor errors in the torsion section and introduce a new section on elongation of members. Note that the title of the chapter has been changed to include elongation of members.

Clause 7.5.2 the maximum allowable shear stress due to combined actions of torsion and shear has been increased from 8MPa to 10MPa to reflect the results of recent testing at the University of Auckland and values used in overseas design codes.

7.6.1.2 the equation for the torsional moment for which torsional reinforcement is not required has been modified to include the influence of axial load and to bring the design approach more into line with ACI318.

In clause 7.6.2 the magnitude of torsional reinforcement that is required where torsion is induced due to compatibility has been modified to ensure that there is no significant loss in shear strength and that the section is ductile in torsion. Provided this minimum level of reinforcement is provided torsional moments can be redistributed.

7.6.4. deals with the case where torsional actions which are required for equilibrium exceed the threshold level (7.6.1.2). There is no significant change to this section.

7.7 Shear friction

This section has been modified to more clearly identify the limitations of the use of shear friction. In the recent past some designers have assumed if the shear friction provisions are satisfied a shear failure will not occur. However, all the provisions do is to ensure that sliding will not occur. Diagonal tension failure, often called a shear failure, can still occur. An attempt has been made to clarify the limitations of the shear friction method. Preference would be for designers to consider strut and tie method of design as an alternative to shear friction.

Clause 7.7.4.1 has been modified to make clear that if reinforcement yields across the plane being considered then crack width can become large and shear friction will not be a valid transfer mechanism. 7.7.4.3 has also been modified to provide some additional information relating to the transfer of forces across an interface by the strut and tie mechanism where the interface is to pre-existing concrete with different levels of surface preparation, or to other surfaces such as structural steel members.

Section 7.8 Elongation

This is a new section which gives expressions for the magnitude of elongation that may be expected in plastic regions. Background material to this clause is given the commentary, C7.8,

In a plastic hinge the magnitude of the tensile strains is considerably greater than the corresponding compression strains and as a result the length of the member increases. With each subsequent inelastic load cycle the length further increases with flexural cracks in the compression zone not fully closing. In beams elongation in each plastic hinge typically exceeds 3 percent of the member depth before strength degradation and shortening occurs. Clause 2.6.5.10 identifies where elongation needs to be addressed in design.

Standard structural analysis packages do not consider elongation and consequently it is important for designers to be aware of this action and make appropriate allowance of any adverse effects. As noted below there are two aspects of adverse action that need to be addressed.

1. Elongation of beams can push other structural elements apart endangering the supports of precast floor units, stairs and ramps and external cladding panels. In addition elongation can create wide cracks in floors partially destroying their ability to act as diaphragms. There were many examples of the sort of damage described above observed in Christchurch as a result of the earthquakes.
2. Elongation of beams, columns or walls can induce structural actions in neighbouring structural elements. For example the formation of a plastic hinge at the base of a wall can result in an increase in height, which is partially restrained by any floors, beams, columns and walls in the vicinity of the member forming the plastic hinge. The axial force induced by this restraint generally increases the strength of the wall but at the expense of its ductility. However, the increased axial load may have implications for the stability of the foundations to the wall. The tension induced in the surrounding elements restraining elongation in the wall can potentially have adverse effects in these members. A second example occurs in coupled shear walls. Elongation in the coupling beams pushes the walls apart. The foundation beam and any floors that are tied into the walls will act to restrain the elongation of the coupling beams. The additional axial force induced in these beams can greatly increase their strength to the extent that the intended ductile behaviour of the coupled wall cannot develop (see 11.4.10).

Chapter 8 Reinforcement details

The modifications to chapter 8 mainly pertain to reinforcing coupling and anchorage systems. The changes have been introduced to ensure greater similarity between NZS3101 and the NZTA Bridge Manual.

The clauses modified include 8.6.11.1 to 8.6.11.4. These clauses relate to mechanical anchors. Basically the clause requires that at the maximum tensile load (~~570MPa for Grade 300 reinforcement and 840MPa for Grade 500~~) the mechanical anchor and the surrounding concrete should not be damaged. In addition when tested with a bar with an average yield strength greater than 500MPa, the failure should be a ductile failure of the reinforcement away from the anchor.

A new clause has been added regarding brittle fracture resistance. This clause becomes more significant when cold service conditions are expected. The system is required to behave in a ductile manner at the service temperatures. ~~The commentary provides further guidance on the interpretation of Charpy V Notch impact testing.~~ As per the Bridge Manual cast iron anchors are not accepted due to non-ductile behaviour.

Clause 8.7.2.8 which covers lap splices of stirrup and ties has been extended to provide further limitations on when straight lap splice of deformed bars can occur in the cover concrete. In addition to the existing 3 restrictions provided in 8.7.2.8(b), a further requirement to stagger the laps has been introduced.

8.7.5.2 which covers mechanical couplers has been modified to link back to the requirements for anchors (see above) as well as retaining change in length requirements.

The requirements for mechanical connections in members subject to seismic actions has also been modified to align with the bridge manual. ~~The testing requirements have been aligned with ISO 15835-2.~~

Chapter 9 Beams and one way slabs

A few changes have been made to chapter 9 to aid comprehension.

Clause 9.3.9.4.14 which provided a waiver from shear testing has been deleted as it conflicted with a clause 9.3.9.4.13 which gives a more accurate representation of the testing required to contemplate the omission of shear reinforcement. Note a high level of proof is always necessary to avoid the minimum shear reinforcement specified in 9.3.9.4.13 given that a shear failure without shear reinforcement is non ductile and can be severely influenced by second order effects such a shrinkage, and thermal effects.

Chapter 10 Columns

Many of the changes within this section are editorial. More significant are –

Clause 10.3.2.3 has reintroduced a maximum slenderness ratio of 100 which used to exist in earlier versions of the standard.

Equation 10-38 has been modified to incorporate a missing strength reduction factor.

10.4.7.2.6. There is an error in equation 10-34 due to a stray square root sign appearing in the equation. The revised equation is;

$$v_c = 3v_b \left[\frac{N_o^*}{A_g f'_c} - 0.1 \right] \geq 0.0 \text{-----(Eq. 10-34)}$$

10.4.7.5.1 which covers confinement and anti-buckling requirements in the ductile detailing length of columns, has been modified to include guidance on columns with h/b>2 and low axial loads. The clause allows a reduction in the required confining reinforcement in the mid region of blade columns. However, the total area of transverse reinforcement should still be greater than that required for nominally ductile members.

Chapter 11 Structural Walls

As outlined in the introduction there were a number of unexpected performance outcomes with structural walls in Christchurch which highlighted gaps in our knowledge. A number of research projects are being initiated to improve our understanding of these members. At this stage a number of amendments are proposed to move designs in the right direction as it will be some time before more rational criteria can be developed from research.

There are numerous changes in the chapter and only the most significant of these are described below.

Changes to this chapter have been introduced to;

- The design of singly reinforced walls;
- Minimum longitudinal reinforcement ratios to ensure multiple cracks can form in a wall so that yielding can spread and ductile behaviour can develop. As noted in the introduction in a number of walls with low reinforcement contents single cracks formed and the bars fractures at the cracks due to the high strains;
- Introduction of axial load limits for walls;
- Detailing requirements for shear reinforcement particularly at the ends of walls;
- Lateral tie requirements in plastic hinge zones.

Singly reinforced walls

A new clause, 11.3.1.5 has introduced the requirement that singly reinforced walls should be designed for nominally ductile actions for in plane loads. The introduction of a strength reduction factor of 0.7 for in-plane actions in 2.3.2.2 means that singly reinforced walls designed using standard ultimate strength theory will sustain ultimate strength actions with no significant inelastic deformation of the reinforcement. The NZS3101 committee understands that singly reinforced walls are often designed for nominally ductile actions so the change may not be as significant as first appears. This change was made due to concerns about the stability and lack of ductility of singly reinforced walls when subjected to bi-axial cyclic loading where extensive yielding is relied upon to develop ductile behaviour. .

An additional requirement has been added to 11.3.1.4 to put an upper limit on the longitudinal reinforcement content of singly reinforced walls. A commentary to 11.3.1.4 has been added to explain that the maximum reinforcement contents of singly reinforced walls approximately corresponds to the limit obtained from balanced strain conditions for out of plane loading in 11.3.11.3(a) which is renumbered in the amendment to 11.3.12.3(a).

In clause 11.3.7, the maximum ratio, $(k_e L_n/t)$ is reduced from 30 to 20 when N^* exceeds $N^* > 0.2 f'_c A_g$.

11.3.11.3 Minimum and Maximum reinforcement

This clause is predominantly unchanged although it has been renumbered to 11.3.12.3. The changes include the removal of the allowance to reduce the required minimum reinforcement ratios if at least one third greater reinforcement is provided than required. However, in later clauses, which apply to ductile and limited ductile walls require different minimum proportions of longitudinal reinforcement to be used. Consequently the minimum proportions in the clause apply only to nominally ductile walls.

11.12.11.5: Anchorage of shear reinforcement.

This new clause requires shear reinforcement in all but singly reinforced walls to be anchored at each end of the wall, either by enclosing the longitudinal reinforcement near the end of the wall with a U shaped bar, or by being anchored within stirrups which enclose the longitudinal reinforcement near each end of the wall. The commentary to this clause provides illustrations to aid interpretation.

11.4.1.1 Maximum axial load actions for ductile walls

The existing clause has been relocated to the 11.3 section of the standard and this new clause added Axial load limits have not previously been included in NZS3101, however given the size of most walls, axial loads are typically relatively low. The Hotel Grand Chancellor in Christchurch demonstrated that for some designs axial load limits for walls are appropriate. This is a new clause limiting the maximum axial load under capacity over-strength conditions, ~~N'_0~~ , to $0.45 A_g f'_c$. However, this axial load is to include the increase in axial load induced by elongation of the wall being considered. The alternative was to provide a conservative limit on the axial load ($0.3f'_c A_g$) when elongation is not considered with the 0.45 limit applying when elongation is considered. Feedback on this step is sought as it could require a significant change in the way in which buildings are analysed.

11.3.1.4 Axial load limit for nominally ductile walls

For walls with curvature consistent with nominal ductility (section 11.3) the ultimate axial load has been limited to $0.3f'_c A_g$. (11.3.1.5). In addition to reduce the risk of buckling, when the axial load on the wall is greater than $0.2f'_c A_g$, the ratio of effective height to thickness of the wall is limited to 20. Furthermore, when the flanges of a wall contribute to resisting flexure in compression, the effective length to flange thickness ratio is also limited to 20. When considering fully ductile walls (excluding nominally and limited ductile) this limit is decreased to $k_e L_n / t_f \leq 15$.

Clause 11.4.4.2 Minimum area of reinforcement in ductile detailing length

This is a new clause which gives minimum reinforcement ratios for vertical reinforcement. These have been selected to ensure that ductile behaviour can be obtained with yielding spreading along the ductile detailing length. Each wall is made up of two different regions. The end region extends for a distance of $0.15L_w$ from each tension face of the wall and the central region between the two end regions. The aim of the increase in minimum reinforcement content in limited or fully ductile walls is to ensure the formation of both primary and secondary cracks. This has been achieved by concentrating reinforcement at each end of the wall (end regions) and maintaining a minimum level of reinforcement in the central region. The minimum reinforcement content in these end regions has been derived with consideration of –

- Concrete strengths being greater than specified and strength increasing with time.
- Load application rates increasing the strength of both concrete and reinforcement.
- Relationships between compressive and tensile strength.
- Upper characteristic strengths.
- Residual tensile stress in the concrete due to internal restraint of drying shrinkage by the reinforcement.

In the ductile detailing lengths of walls designed for limited or fully ductile actions, in the central region of the wall ($0.7L_w$) the required longitudinal reinforcement ratio remains as defined in NZS3101:2006. However in the end $0.15L_w$ of the wall the required reinforcement ratio has been doubled. Refer 11.4.4.2 for details. To ensure that a reasonable degree of

distribution of reinforcement occurs, there is also a requirement that the reinforcement ratio in the middle section of the wall shall not be less than 30% of that in the end region of the wall.

Lumping reinforcement at the ends of the walls ensures the initiation of primary cracks, and the requirement for 30% of the end reinforcement ratio in the central region of the wall ensures the initiation and propagation of secondary cracks. If the quantity of vertical reinforcement in the end zone ($0.15L_w$) is significantly greater than the quantity of distributed vertical reinforcement in the central region, the wall can be susceptible to widely spaced cracks in the central region which can result in poor shear resistance and higher shear deformations.

The actual concrete strength being higher than expected is due to both the required target ready mix concrete strengths in NZS 3104:2003 being greater than f'_c , as well as strength growth with time. Additionally, dynamic application of loads during an earthquake increases both the tensile and compressive strength of concrete.

Use was made of flexural beam results provided by many NZ ready mixed concrete companies for determining probable tensile strengths.

Details of the factors forming the minimum reinforcement requirements are shown in Equation 1.

$$A_{s,\min} = \frac{1.2 \times 0.85 \times 0.52 \sqrt{1.2 \times 1.1 \times f'_c}}{1.1 \times 1.08 \times f_y} \quad \text{Equation 1}$$

$$A_{s,\min} = \frac{0.5 \sqrt{f'_c}}{f_y} \equiv \frac{\sqrt{f'_c}}{2f_y} \quad \text{Equation 2}$$

Each factor in Equation 1 is given below:

- 1.2 relates to the tensile strength increase of concrete due to dynamic loading
- 0.85 relates to the drying shrinkage of concrete imposing tensile strains into the concrete.
- 0.52 relates the mean tensile strength to the upper characteristic (95%ile) tensile strength of concrete
- 1.2 relates the average target compressive strength given in NZS 3104:2003 to the lower characteristic (specified) strength (5%ile)
- In the numerator, 1.1 relates to the increase in concrete compressive strength due to age.
- In the denominator, 1.1 relates to the tensile strength increase of steel reinforcement due to dynamic loading
- 1.08 relates the lower characteristic (specified) strength of reinforcement to the mean strength

11.4.5.2 and 11.4.5.3 Lateral tie requirements in plastic hinge zones.

In NZS 3101:2006, requirements for the transverse reinforcement in plastic hinge zones were described in clause 11.4.6.3. This required transverse reinforcement around bars which could yield in compression with an exclusion that if the reinforcement ratio was below $2/f_y$ for ductile and $3/f_y$ for limited ductile plastic hinge regions. Possibly not overly clear in NZS3101:2006 was that these requirements applied to any bar which could yield in compression and not only the reinforcement in the compression zone. As a loading direction reverses in a ductile wall, the tension reinforcement in the centre of the wall needs to yield in

compression and therefore has the potential to buckle. The amendment has taken a revised approach to preventing premature buckling of longitudinal reinforcement in walls. The existing clause 11.4.6.3 has been deleted and replaced by two clauses 11.4.5.2 and 11.4.5.3 (the different numbering arising due to rearrangement of the chapter).

Clause 11.4 5.2 provides transverse reinforcement requirements in the compression zone of the wall. The requirements are those to prevent buckling and are similar to the previous clause described above but with the exclusion for low reinforcement contents removed.

For the central portion of the wall (between the neutral axis depths as loading reverses) the requirements for transverse reinforcement are described in 11.4.5.3. The aim of the clause is to minimise spalling and therefore the potential for the central bars to buckle with the potential loss of integrity of the concrete in the core of the wall. Three factors have been considered important, the magnitude of the diagonal compressive force (represented by the shear stress), the cover to the vertical bars, and the likely inelastic strains the central bars will experience. 11.4.5.3 requires transverse reinforcement linking the central bars in the wall unless all of the following are satisfied-

- the shear stress is less than $0.075f_c$
- the cover to the vertical bars is greater than $1.5d_b$
- the curvature demand in the plastic hinge zone is less than that associated with a limited ductile wall, ie a K_d less than 6 as defined by Table 2.4

The NZS3101 committee particularly solicits feedback on this new clause during the public comment stage.

11.4.9 Coupled shear walls

The existing NZS3101:2006 clause 11.4.9 has been renumbered and is now 11.4.8. The clause number 11.4.9 is now used in the amendment to cover new criteria on coupled shear walls.

There are no criteria given in the current Standard related to the design of coupled walls. The addition of this new clause is an attempt to partially rectify this omission. A major problem in current practice, which was highlighted in the analysis of the CTV building (Royal Commission Report, Vol. 6), is the failure to consider the implications of elongation of coupling beams. As sway develops the coupling beams push the coupled walls apart. The increase in horizontal displacement is partially restrained by the foundation beam and floors or other structural elements that are connected to the coupled walls. The action of floors is relatively easy to envisage. As the walls are pushed apart tension is resisted by the floors and axial compression is induced in the coupling beams. This compression force can very significantly increase the vertical shear force that these elements can transfer between the coupled walls. In the case of the CTV building this increase in shear resistance of the coupling beams appeared to explain why the coupled wall did not behave as the ductile element intended in the design.

The new clause on coupled walls sets out how allowance for the restraint forces provided by the floors and the corresponding increase in shear transfer between the coupled walls. However, there is a more complex problem that is not addressed in the proposed amendment. This relates to the restraint provided by the foundation beam. Elongation of the coupling beam or beams near the foundation beam imposes horizontal shear forces in the walls, increased curvature demands on the plastic regions at the base of the walls, negative moments in the foundation beam and it restricts the inelastic deformation in the lower coupling beam or beams.

The behaviour of coupling beams is currently being investigated at the University of Auckland.

Chapters 12, 13, 14, 15, and 16

The changes to these chapters are small and editorial in nature.

Chapter 17

Corrections include changing the word “fixings” to the more correct term of “anchors” ~~which is consistent with ACI318. The committee evaluated the possibility of including post installed anchors into the scope of the chapter but decided to explore this opportunity in future amendments.~~

Chapter 18

Many of the changes in chapter 18 were editorial and are designed to assist in interpretation of the clause. 18.6.7.1 Includes inserting the word “peak” into the sentence relating to inter-storey drifts. Refer to the comments on clause 2.3.3.3 for an explanation of this.

Precast concrete flooring seating lengths

Section 18.7.4 and section 18.8 have been extensively modified to provide better guidance on appropriate seating lengths for precast elements. Given that the consequences of seating failure can be significant, a degree of conservatism is appropriate. The proposed amendments recognise that in some instances precast elements do not rely on the seating for transfer of loads, an example would be a precast beam framing into a column. The proposed amendments do not apply to these elements where the seating is not the primary mechanism for transfer of gravity loads. However in most instances for flooring systems the seating is an important mechanism for transferring gravity loads and therefore its performance post a seismic event needs careful consideration.

The amendment provides minimum seating requirements which are provided in section 18.7.4.3. However the clause recognises that where elongation is likely to cause separation of the floor from the supporting element, or where spalling is possible due to prising due to moderate inter-storey drift, then larger seating lengths are appropriate. Guidance for is provided in clause 18.8.1. The required seating length is the sum of the following-

- The bearing length required at the ultimate limit state. Note often this number is considerably smaller than the bearing width provided and maybe a fraction of the width of the bearing pad.
- An estimate of the amount of spalling on the outside face of the supporting member. The clause provides guidance for appropriate assumptions both within and outside of the plastic hinge length.
- Potential spalling of the end of the precast element.
- Loss of seating length due to frame elongation.
- Loss of seating length due to rotation of the supporting member.
- An allowance for construction tolerances.
- Loss of seating due to creep, shrinkage and or thermal effects.

In many cases, after consideration of all the above considerations the seating lengths in flexible and ductile buildings will be in the order of 125-150mm.

Chapter 19

No changes were made to the prestress section as it was outside the terms of reference.

Appendix E

Bridge engineers, where the lengths of beams are often considerably larger than found in buildings, often have to grapple with how to design for creep, shrinkage and redistribution of structural actions due to stage construction. Appendix CE used to provide information on how to consider these consideration but did not provide information on typical NZ values for creep and shrinkage. Also missing was how shrinkage values obtained from small test specimens are modified to give values appropriate for design. Conversely, after designing a structure based upon certain shrinkage assumptions, what the designer needs to specify as the performance target for the concrete mix design was also missing.

In most situations the best economics are achieved by designing for the materials which are readily available. Therefore some knowledge of the local shrinkage values is required. Tables are provided of typical shrinkage values obtained by testing using AS1012.13.

The section is a modification of what is used in Australian design practice. The procedures have therefore been built around the AS1012.13 shrinkage test. It should be noted that both creep and shrinkage are effected by the size of the specimen, humidity, and the duration of the test. When looking at data from other sources it is important to appreciate these factors.

Shrinkage is considered to the sum of two components, the autogenous shrinkage, and drying shrinkage. Autogenous shrinkage occurs predominantly as the chemical reaction of water and cement results in a small reduction in volume. The greater the concrete strength the greater the autogenous shrinkage. The rate of volume change with autogenous shrinkage occurs quickly and 50% of this form of shrinkage can occur within the first 7 days, This form of shrinkage is also largely unaffected by humidity and size effects.

Drying shrinkage occurs as free water slowly exits the capillaries within concrete and in doing so creates large negative internal pressures which result in volume reduction. As this form of shrinkage is dependent upon the movement of water it is effected by the ambient humidity and the size of the member. The relationship between compressive strength and drying shrinkage is complex. As the w/c ratio decreases (stronger concrete) the drying shrinkage of the paste decrease. However the amount of paste generally increase as higher strength is normally achieved by adding more cement. In most common situations, increasing concrete strength results in higher drying shrinkage.

As autogenous and drying shrinkage occur at different rates and both are influenced by different variables the procedure involves considering these influences separately. However, when conducting a shrinkage test in accordance with AS1012.13, the measurement of shrinkage commences at day 7. This means that the values obtained from the test will include a component of both autogenous and drying shrinkage. The commentary provides some guidance on how to consider this.

The section should provide better understanding of concrete shrinkage and also provide better specifications.

DESIGN OF RC WALLS POST THE CANTERBURY EARTHQUAKES

Alistair Russell¹, Rick Henry² and Richard Fenwick³

¹Cement and Concrete Association of New Zealand (CCANZ)

²Department of Civil and Environmental Engineering, University of Auckland

³Adjunct Professor, University of Canterbury

Abstract

The seismic behaviour of reinforced concrete (RC) walls has received significant attention following the Canterbury earthquakes. The poor performance of some RC walls in several modern buildings raised questions regarding the current state of RC wall design and construction practice. In response to the concerns raised, the provisions in the Concrete Structures Standard (NZS 3101:2006) have been re-examined and amendments proposed. Following the earthquakes, both the Canterbury Earthquakes Royal Commission (CERC) and the Structural Engineering Society (SESOC) recommended changes to current design practice and to standards to address the identified deficiencies. Several key considerations for RC wall design are discussed with respect to the issues raised by CERC and SESOC, and these have been addressed in Amendment 3 to NZS 3101:2006. These amendments will result in significant changes to RC wall design provisions in relation to the minimum vertical reinforcement limits, confinement reinforcement, detailing of shear reinforcement, axial load limits, coupled wall systems and the detailing of singly reinforced walls.

Introduction

A number of structural reinforced concrete (RC) walls that were examined by the Canterbury Earthquakes Royal Commission (CERC) performed poorly during the earthquakes with unexpected and/or undesirable behaviour. In some cases the poor performance appeared to be largely due to basic structural mechanics issues not being adequately addressed. To understand the reasons for the observed poor performance and to produce safe designs it is essential to have a good basic understanding of structural engineering concepts.

In response to issues identified by CERC and the Structural Engineering Society (SESOC, 2011; 2013), significant changes are being made to NZ 3101:2006 in the form of Amendment 3, which it is planned to publish in late 2015. In addition to numerous editorial changes (including terminology and clause order), important changes were made to most sections of the Standard, and particularly to Chapter 11 which covers RC walls. Some of the noteworthy changes made to other chapters included:

- Consideration of member elongation, which was the cause of significant damage in the Canterbury earthquakes
- Changes to support details for precast floor, stair units and panels
- Changes in the way that member stiffness values are calculated for seismic analyses.

Further details of the major changes proposed in Amendment 3 can be found in Cook et al. (2014).

Assessment of RC wall performance resulted in significant changes to Chapter 11 of NZS 3101:2006, based on inadequacies found in design and detailing in the following areas:

- Minimum reinforcement limits
- Singly reinforced walls

- Transverse reinforcement and detailing, including an increase in confinement reinforcement
- Global wall buckling and instability – axial load limits and slenderness
- Wall elongation
- Low aspect ratio walls
- Coupled wall systems

Background – Observed Wall Damage and Implications

Two of the RC walls that were assessed by the CERC had been designed or assessed using stiffness for analysis that were based on the assumption that extensive flexural cracking would occur over the whole height of the wall. However, relatively simple calculations, backed by observed crack patterns, indicated that flexural cracking was limited to one or two sections. The consequence was that the calculated fundamental periods were too high and the required design strength was too low. The lack of sufficient vertical reinforcement in both cases led to fracture of the reinforcement due to yield being confined to the immediate vicinity of the cracks. One of these cases, being the Gallery Apartments Building, is described in greater detail below.

Torsional resistance in a beam, a shear core or a column requires that the diagonal compression forces, which resist the torsional shear stresses at a section, are balanced by tension forces in the transverse and longitudinal reinforcement. In one of the buildings, a shear-core, which was eccentric to the centre of mass of the building in plan, provided the lateral seismic strength of the building. For this purpose the shear-core needed to sustain uncoupled flexural and torsional actions in an earthquake. When the longitudinal flexural tension reinforcement yields in tension the capacity of this reinforcement that is required for torsion is lost. This results in a loss of torsional resistance and failure can occur by rotation of the shear core leading to collapse of the building. For this building a flexural torsional failure of the shear core appears to be a likely cause of collapse (PGC building).

In walls subjected bi-axial flexure and shear there are some basic problems in assessing shear strength. Relatively simplistic analyses indicate that under this loading condition there is likely to be a significant decrease in out of plane shear strength of the member when it is subjected to high axial loading. In one multi-storey building a wall that was subjected to relatively high axial loading failed in the earthquake. Initially this was put down to the lack of confinement reinforcement in the wall. However, as the wall would also have been subjected to appreciable out of plane displacement due to torsional response of the structure, it is likely that the failure was triggered by a shear failure where the shear resistance was reduced by the axial loading and the in plane flexural and shear forces.

Lack of Distributed Flexural Cracking

Assessments of buildings following the Canterbury earthquakes highlighted several examples of RC walls in multi-storey buildings that had formed a single flexural crack in the plastic hinge region as opposed to the expected larger number of distributed cracks (CERC 2012a, Sritharan et al. 2014). After breaking out the surrounding concrete it was found that the vertical reinforcing steel was often fractured due to the inelastic strain demand at the crack location. If too little vertical reinforcement is used in walls, there is insufficient tension transferred across the crack to exceed the tensile strength of the concrete surrounding the reinforcement and as a result secondary cracks cannot form. In this situation tests on bars extracted from other buildings where single major cracks had formed indicated that yielding of the reinforcement was limited to fewer than two bar diameters on each side of the crack. Consequently relatively modest crack widths of the order of a few mm can lead to strain levels that may fracture the bars. Such walls lack ductility and perform poorly during earthquakes. To obtain ductile performance a series of secondary cracks must form so that

yielding can extend for some distance along the wall. The Canterbury Earthquake Royal Commission recommended that research be conducted to refine design requirements for crack control in RC walls (CERC 2012a).

As part of the CERC (2012a) a detailed investigation was conducted into the performance of the Gallery Apartments building (Smith and England 2012). The reinforced concrete walls in the Gallery Apartment building contained less vertical reinforcement than is required by the current design standard NZS 3101:2006, but it complied with the 1995 edition of the Standard. The walls were observed to have formed a small number of cracks at the wall base. As highlighted in volume 2 of the CERC report (2012a), the quantity of vertical reinforcement in the Gallery Apartment walls was insufficient to develop the tension force required to form further cracks. Additionally, samples extracted from the Gallery Apartments building following the earthquakes indicated that the concrete strength was significantly higher than the specified concrete strength (Holmes Solutions 2011). The higher concrete strength further increased the likelihood of a single crack formation and fracture of vertical reinforcing steel. Both moment-curvature and detailed finite element analysis conducted of the grid-F wall in the Gallery Apartments building confirmed the observed earthquake performance (Henry 2013, Sritharan et al. 2014). When the as-built reinforcement content and concrete strength were used, a single flexural crack was predicted to form when subjected to lateral load with premature fracture of the vertical reinforcement. It should also be noted that this analysis confirmed that the stiffness of the wall was likely to be closer to the gross section stiffness rather than the reduced cracked section stiffness used during the design.

Minimum Vertical Reinforcement Limits

Historically, minimum requirements for vertical reinforcement in RC walls were governed by shrinkage and temperature effects. More recently, minimum vertical reinforcement limits for RC walls have been increased in design standards worldwide to ensure that ductile behaviour is achieved when yielding of reinforcement is expected. In the 2006 revision of NZS 3101, the minimum required vertical reinforcement in RC walls was increased by over 80% with the adoption of a similar equation to that previously used for RC beams. Because of these recent changes, some of the RC walls in Christchurch that were observed to have only a few flexural cracks and fractured vertical reinforcement had vertical reinforcement contents below the current limit in NZS 3101:2006.

As discussed by Henry (2013), the current minimum vertical reinforcement limit for RC walls may not be appropriate as the margin of separation between cracking and nominal strength would be less than for an equivalent beam unless a significant axial load is applied. A series of large-scale tests were conducted and supported by additional numerical analysis to investigate the seismic behaviour of RC walls with vertical reinforcement in accordance with the current minimum limits in NZS 3101:2006 (including Amendment 2, A2) (Lu et al. 2014, 2015). Based on this research the following conclusions were drawn:

- Current NZS 3101:2006 (A2) requirements for minimum vertical reinforcement are sufficient to prevent a non-ductile response, but deformations are still concentrated at a limited number of flexural cracks and these walls are susceptible to bar buckling and fracture failure at low lateral drifts.
- Placing additional reinforcement at the ends of the wall beyond that required by NZS 3101:2006 (A2) significantly increased the distribution of cracking and ductility of the wall.

NZS 3101 A3 – Nominally Ductile

The existing requirements for minimum vertical reinforcement were retained with two minor changes. The notation was changed from a total vertical reinforcement ratio to a distributed

vertical reinforcement ratio (ρ_l), and the previous clause that allowed the limit to be related when the nominal strength exceeded the design strength by 30% was removed. The performance of these lightly reinforced walls was also improved by refinement of requirements for singly reinforced walls and transverse ties as discussed below.

NZS 3101 A3 – Ductile and Limited Ductile

For ductile and limited ductile hinge regions additional vertical reinforcement is required to ensure the required hinge rotations can be sustained during an earthquake. As per recommendations from research (Henry, 2013; Lu et al. 2014, 2015), it was proposed to increase the reinforcement in the ends of the wall. The initial primary flexural crack in a wall is induced when the tensile stress in the concrete is exceeded. This crack will extend from the extreme tension fibre to close to the zero strain fibre, and generally the crack length will exceed half the wall length. The minimum vertical reinforcement proportion in the end regions of the wall has been determined to ensure that before the reinforcement yields a series of secondary cracks will have also formed adjacent to the primary crack. This is essential to enable yielding to spread over a length of the wall to enable ductile performance to develop. If the series of secondary cracks cannot form, a brittle failure may occur similar to that observed in the Gallery Apartments building.

To achieve this secondary crack formation, the tension force transmitted across the cracks in the end region must exceed the tensile strength of the concrete in this region. The requirement for minimum vertical reinforcement in the end zone was determined by equating the tensile force provided by the vertical reinforcement in the end zone with the expected maximum long-term tensile strength of the concrete in the end zone to ensure that secondary cracks would form. Consideration was given to the following aspects:

- Concrete strengths being greater than specified and strength increasing with time
- Earthquake strain rates increasing the strength of both concrete and reinforcement
- Relationships between compressive and tensile strength of NZ concrete
- The maximum likely tensile strength of the concrete
- Residual tensile stress in the concrete due to internal restraint of drying shrinkage by the reinforcement

Details of the numerical factors that were used to derive the minimum reinforcement requirements are shown in Cook et al. (2014).

The end zone, requiring additional vertical reinforcement, extends $0.15L_w$ along the wall length at each end of rectangular walls, or from the ends of flanges and webs in non-rectangular walls. The end zone definitions are shown in Figure 1 for different wall geometries.

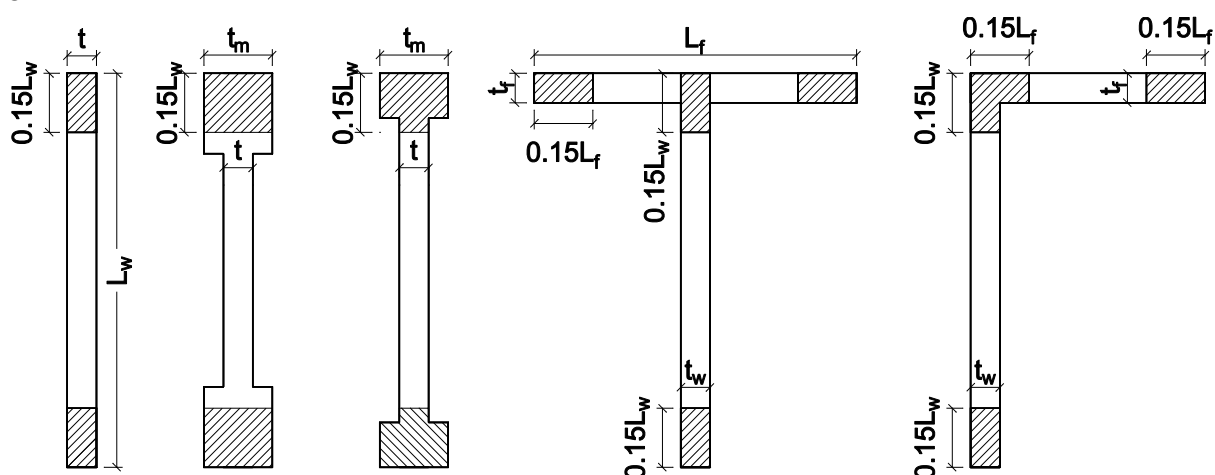

Figure 1: End zone definition for different wall geometries

If the quantity of vertical reinforcement in the end zone ($0.15L_w$) is significantly greater than the quantity of distributed vertical reinforcement in the central region, without distributed reinforcement in the central region of the wall the secondary cracks will not extend into the wall far beyond the end regions, and the wall can be susceptible to widely spaced cracks in the central region which can result in poor shear resistance and higher shear deformations (Sritharan et al 2014). Lumping reinforcement at the ends of the walls ensures the initiation of primary and secondary flexural cracks, and an additional requirement for 30% of the end reinforcement ratio in the central region of the wall (between end zones) ensures that these cracks propagate through the length of the wall. A second requirement for this central reinforcement is to ensure that the bending moment transferred across the crack is sufficient to enable other primary cracks to form higher up the wall.

Singly Reinforced Walls

In Amendment 3 to NZS 3101:2006, singly reinforced walls are no longer permitted to be designed for ductile or limited ductile regions. Whilst research and some experiences in the Canterbury Earthquake sequence demonstrated ductility of singly reinforced walls, these walls are thought to lack the robustness and ductility to sustain significant damage while retaining lateral stability, particularly when considering multi-directional actions. Included in the lack of robustness were uncertainties relating to:

- Connections and bar anchorage
- Shear and stability
- Fracture of reinforcement
- Reliance being placed upon extensive yielding to develop ductile behaviour

Consequently, to allow for their uncertain performance in earthquakes, singly reinforced walls which form part of the primary lateral load resisting system are to be designed for nominal ductility ($\mu=1.25$) combined with a strength reduction factor of 0.7. The strength reduction factor of 0.7 is a result of combining the “usual” wall strength reduction factor of $\phi = 0.85$ with an additional factor of 0.8. The 0.8 factor is the ratio of the flexural strength at first yield to the ultimate strength. The product of 0.85 and 0.8 gives 0.68 which was rounded to 0.7. With the reduced strength reduction factor the wall should resist the ultimate strength actions with negligible inelastic deformation and sustain only relatively minor inelastic deformation in the maximum considered earthquake.

The maximum vertical reinforcement content in singly reinforced walls is limited by the requirement that they satisfy the condition for nominal ductility for out of plane bending. For this condition the neutral axis depth must be equal to or less than 0.75 times the corresponding depth at balanced conditions (see clause 7.4.2.8), that is $c > 0.75c_b$. Hence, for a singly reinforced wall reinforced with Grade 500 reinforcement, the limiting vertical reinforcement proportions for concrete strengths of 30 MPa and 50 MPa are 1.18% and 1.6% respectively. To be consistent with other equations for walls these percentages are expressed in terms of the total width of the wall.

Anchorage of Horizontal Reinforcement

SESOC (in the Interim Design Guidance) (2013) noted that reinforcement confinement was important for the performance of doubly reinforced walls in the Canterbury Earthquakes. Amendment 3 to NZS 3101 now explicitly requires the ends of wall segments to be locally confined to provide adequate anchorage and development of horizontal reinforcement, and to transfer loads through a diagonal compression strut into the end vertical (longitudinal) bars. This can be achieved by using one of the following alternatives;

- bending the horizontal reinforcement around both of the corner end bars to form a continuous U shaped bar (Figure 2(a));

- bending the horizontal reinforcement around a corner bar at the ends of the wall with a 135° hook; with those two corner bars at the end of the wall then linked with an effective tie (Figure 2(b));
- anchoring the horizontal reinforcement as close as practical to the end of the wall with horizontal 90° or semi-circular hooks, with these hooks terminating within a horizontal closed cage which encloses at least 4 vertical bars at the end of the wall (Figure 2(c)).

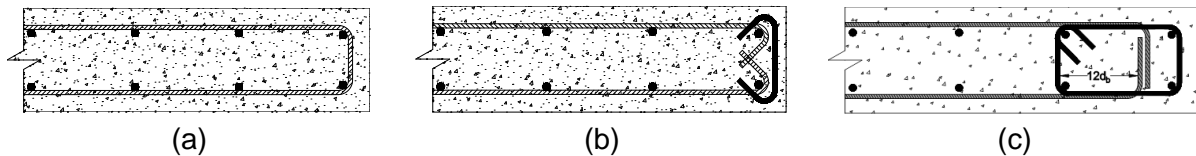

Figure 2: Anchorage of horizontal reinforcement (dimensions exaggerated for illustrative purposes)

Similar anchoring details are required for horizontal reinforcement at the intersections in C- or T-shaped walls. Because singly reinforced walls will be effectively designed to behave elastically, no such detailing requirements are included in Amendment 3.

Local Buckling of Bars in Mid Regions of Walls

In the Interim Design Guidance, SESOC (2013) noted that buckling of vertical reinforcing steel in concrete walls with confined boundary regions was observed in several buildings in Christchurch. Bar buckling was not limited to the ends of the wall, but it also occurred along the wall length and led to lack of containment of large sections of concrete in the web region. When subjected to in-plane actions, a wall with distributed vertical reinforcement and a low axial load ratio would exhibit a strain profile at ULS such that most of the wall (and reinforcing bars) would be in tension, with a comparatively shorter length of the wall in compression. When the earthquake force reverses the bars that had previously yielded in tension would now be subjected to compression, and those bars which had sustained an appreciable level of tension strain would then have the potential to buckle in compression. Whilst those bars in the compression zone on the ULS strain profile (within a length of c , the neutral axis depth, from the ends of the wall) would be provided with anti-buckling and confinement reinforcement, there could be a portion of the middle part of the wall where the tension strain was such that the bars when subjected to compression would be susceptible to buckling. In developing the design criteria it has been assumed that bars not constrained by ties, which sustain a tensile strain in the ultimate limit state greater than $8\varepsilon_y$ are susceptible to buckling when subjected to compression. Further research on this critical strain limit is required, and consequently the following design criteria are tentative. In limited ductile walls the strain limit ($8\varepsilon_y$) is seldom reached due to the limited material strain (curvature) permitted in the plastic hinge region. Consequently for limited ductile plastic regions no additional ties are required.

For ductile plastic regions the permissible curvature limits are considerably higher, which enables appreciably greater strains than $8\varepsilon_y$ to be induced in the reinforcement in the mid region of wall. In this situation, unless it can be shown that the concrete surrounding the reinforcement is intact, so that it can provide lateral restraint to the reinforcement, containment reinforcement, which consists of ties that hold the two sides of the wall together, is required over the length of the effective plastic hinge. It is assumed that the concrete surrounding the vertical reinforcement will be intact where the three criteria given below are all satisfied. Where this is the case no containment reinforcement is required.

The three criteria are:

1. The spacing of the vertical bars is greater than $5d_b$. A close spacing of bars can result in a crack forming in the plane of the bars, which would increase the tendency for spalling.

2. The clear cover to the vertical bars is equal to or greater than $1.5d_b$. Thin cover encourages tensile splitting cracks to form along the bars and the lateral resistance that can be provided to restrain buckling is reduced.
3. The shear force acting on the wall is less than $0.075f'_c 0.8L_w t$, where L_w is the length of the wall and t is the thickness. This limit was set on the basis that;
 - the diagonal compression stresses associated with shear would be confined to half the wall thickness due to out of plane bending,
 - the shear stresses in the mid region of the wall are greater than the average shear stress.

Based on these assumptions the diagonal compression stresses are close to $0.4f'_c$, which is close to the limit that can be sustained in a region containing diagonal cracks.

Global Wall Buckling and Instability

For walls with high axial loads, ($N > 0.2\phi f'_c A_g$), the ratio of effective height to thickness ($k_e L_n / t$) has been reduced in Amendment 3 to NZS 3101 from 30 to 20 to reduce the effects of lateral flexural torsional buckling. The reason for this reduction is to simply increase the level of robustness, noting that walls may be subjected to both in-plane and out-of-plane actions during an earthquake. In a similar manner, the effective height to thickness ratio of flanges is also now 20 when the overhang length of the flange on the side of the web is of an appreciable length that buckling could be a concern (flange overhang $\geq 3t_f$), and when the flange contributes to the flexural resistance of the wall. In plastic hinges of fully ductile wall structures, this limit is reduced to 15, and again is to safeguard against out-of-plane buckling of thin and wide flanges.

Global wall buckling and instability are not simple phenomena, and for this reason the above reductions in effective height to thickness have been implemented for robustness purposes primarily. By this means allowance has been made to reduce the potential adverse effects associated with global wall buckling.

Axial Load Limitations

The axial load is another contributing factor to global buckling of RC walls. There is currently insufficient evidence and data to support a more comprehensive analysis of the effect of axial load, but it was considered that axial load limitations should be introduced. The exact calculation of axial loads on RC walls during earthquakes is complex and involves consideration of building interactions. The formation of a plastic hinge in a wall can cause significant elongation to develop. The resultant vertical displacement can be partly restrained by surrounding structural elements, potentially significantly increasing the axial load on the wall. As an interim solution, the ultimate axial load for all walls has been limited to $0.3f'_c A_g$ when considering earthquake actions. This limit excludes axial load induced by elongation. The corresponding limit for non-seismic load combinations is $0.4f'_c A_g$. The imposed actions due to earthquake loading are less certain than for gravity loading and it is impractical to calculate the additional axial loading associated with elongation which is discussed below in more detail.

Elongation

Flexural cracking in most RC members causes elongation to occur as the tensile strains are greater than the corresponding compression strains. Generally in the serviceability limit state the effects of elongation are minor. However, when plastic hinges form, the magnitude of elongation increases, and significant interactions can occur between structural elements. A lot of structural damage in the Canterbury Earthquakes was caused by elongation. A major difficulty in dealing with the adverse effects of elongation arises from:

- Most currently used methods of structural analysis do not include elongation
- Much of our design criteria for structural elements has been developed from structural tests and analyses of individual structural elements in which the interactions with other structural elements have not been considered.

Elongation of coupling beams pushes the coupled walls apart. This relative movement will be partly restrained by any floor slabs that are connected to the walls and by the stiffness of the foundation beam. The tension force resisted by the slabs is balanced by a compression force in the coupling beams, which can significantly increase their shear strengths. This action prevented the coupled shear walls in the CTV building behaving in the intended ductile manner (CERC, 2012b). The enhanced strength of the coupling beams, due to the restraint provided by the floor slabs, increased the strength of the beams to the extent that inelastic deformation was induced in the walls causing a premature limited ductile failure. Clauses detailing how strength enhancement of coupling can be assessed have been added to NZS 3101:2006 in Amendment 3, together with design criteria to ensure inelastic deformation is confined to the chosen locations that have been detailed to sustain inelastic deformation in the coupled walls.

When a plastic hinge forms at the base of a wall, or other location, elongation occurs. The increase in height of the wall can be partly restrained by forces that are transferred to columns or other walls by the flexural, torsional and tensile membrane stiffness and strengths of the floors and beams. This action can increase the axial load on the wall and induce tension in columns and other walls in the structure. Elongation can have a major effect on the seismic performance of a building and it is difficult to assess in design (Wight, 1985). As it is impractical to expect designers to determine the potential increase in axial load due to elongation, the limiting design axial load has been reduced and the confinement requirements for the flexural compression zone of walls have been increased. By this means allowance has been made to reduce the potential adverse effects associated with this action, though there may still be potential problems in the foundations.

Squat Shear Walls

In structural walls, where the aspect ratio (M^*/V^* or h_w/L_w) is low, such as can occur in podium type structures where high shears are transferred from the tower to the perimeter walls, the horizontal shear reinforcement becomes less effective than vertical reinforcement for shear resistance. In such walls, the vertical reinforcement provided to resist flexure may be insufficient to maintain shear resistance. Additionally, the flexural design principle of plane sections remaining plane breaks down, and a strut-and-tie analysis may be a more suitable design method.

With a strut-and-tie approach the shear stress resisted by concrete, v_c , should be taken as zero, and the strut angles of the compression forces to the horizontal plane, which are used to resist shear and flexure, must equal or exceed 30° . The limit of 25° given in Appendix A of NZS 3101:2006 is increased to 30° to allow for the inelastic cyclic loading that occurs in earthquakes.

An alternative to the strut-and-tie method of analysis and design is to design for flexure but provide a minimum amount of distributed vertical reinforcement (ρ_{lm}) to ensure that the shear forces can be adequately resisted. The reinforcement proportion ρ_{lm} corresponds to a minimum area of distributed reinforcement for shear. If the distributed reinforcement provided for flexure exceeds this value then no additional vertical reinforcement would be required for shear.

In NZS 3101:2006 Amendment 3 a new clause has been introduced so that where the M^*/V^* ratio is less than 0.75, or where the h_w/L_w aspect ratio is equal to or less than 0.5, the

minimum proportion of vertical reinforcement, p_{lm} , for shear resistance, at any location along the length of the wall is either based on the strut-and-tie method, with the stipulations given above, or determined by the following equation:

$$p_{lm} \geq \frac{v_s}{f_y} \quad \text{Equation 1}$$

In Equation 1, v_s is the shear stress resisted by horizontal web reinforcement, which is given by:

$$v_s = \frac{V_s}{0.8L_w t} \quad \text{Equation 2}$$

and the minimum proportion of vertical reinforcement at any section along the wall is given by:

$$p_{lm} = \frac{A_{sb}}{s_h t} \quad \text{Equation 3}$$

where, A_{sb} is the area of vertical reinforcement within a spacing of s_h and t is the width of the wall at the location being considered.

The above Equation 1 effectively ensures that in those walls with low aspect ratios, as described above, the amount of vertical shear reinforcement is equal to or greater than the amount of horizontal shear reinforcement. This new approach in Amendment 3 for Chapter 11 of NZS 3101 for shear reinforcement in low aspect ratio walls is similar to the approach given in ACI 318-14.

Coupled Wall Systems

Several different methods of modelling coupling beams in coupled shear walls have been proposed. Santhakumar (1974) initially developed an equivalent stiffness based on a truss mechanism and Paulay (1981) developed equations in which the shear deformation that developed in coupling beams was allowed for by modifying the flexural stiffness of the coupling beams. This approach was included in the Paulay and Priestley (1992) textbook. However, neither the book nor the report (1981), or the references in either text, gave the basis of the approach. In a later paper Paulay (2003) further developed the approach suggested by Santhakumar (1974) in which the effective stiffness of diagonally reinforced coupling beams was found from calculated deformation of the diagonal reinforcement Paulay (2003). While this approach is theoretically attractive there are difficulties with it in that the stiffness at first yield is calculated assuming that there is appreciable yield penetration of the diagonal reinforcement into the walls, which is unlikely at first yield, and that tension stiffening of concrete surrounding the diagonal bars is neglected. In terms of practical use, this approach has the added though minor disadvantage of requiring the quantity of diagonal reinforcement to be known before the beam stiffness can be determined. When checking the two approaches against each other it was found that there were major differences in the predicted stiffness values of identical beams. In Amendment 3 for NZS 3101:2006 it was decided to base stiffness of coupling beams on the approach given in the Paulay and Priestley book (1992). However, it should be noted that this method does not allow for the change in stiffness associated with different proportions of diagonal reinforcement.

In the Paulay and Priestley book (1992) the effective stiffness, I_e , of diagonally reinforced coupling beams is given by the following equation:

$$I_e = 0.4 I_g / (1 + 3(h_b/L_n)^3) \quad \text{Equation 4}$$

where I_g is the gross section stiffness of the coupling beam, h_b is the overall beam depth and L_n is the clear span. The $0.4I_g$ is a basic stiffness for rectangular beams used at the time when Grade 300 reinforcement was used. To enable the approach to be used with different reinforcement grades, and in cases other than coupling beams with equal moment capacities

at each end, the corresponding values in the proposed Amendment is given as a basic stiffness for rectangular beams (see Table C6.5 in NZS 3101) multiplied by a coefficient given for different M/Vh_b values in a table. The resultant stiffness values are essentially identical to those referenced in the Paulay and Priestley book (1992) except for the basic flexural stiffness of rectangular beams being $0.33I_g$ for beams with Grade 500 reinforcement and $0.4I_g$ for Grade 300 reinforcement.

For coupling beams with conventional reinforcement, the corresponding stiffness values are taken as half the values used for beams with diagonal reinforcement. The shear stress limit, v , for conventionally reinforced coupling beams given in (Paulay and Priestley, 1992) is equal to:

$$v \leq 0.1(l_n/h_b)\sqrt{f'_c} \quad \text{Equation 5}$$

This limit was introduced to ensure that excessive plastic rotations were not induced in the beam. However, as the section rotation limits are directly controlled elsewhere in the Standard this limit is not used. The requirement that diagonal reinforcement is required where the shear stress exceeds $0.25\sqrt{f'_c}$ given in Chapter 9 of NZS 3101 still applies.

Conclusions

This paper has highlighted some of the current challenges for RC wall design resulting from the Canterbury earthquakes, and the significant changes that have been incorporated into NZS 3101:2006 through Amendment 3. Whilst most of the changes are credibly supported by mature research, several changes have been incorporated to provide an increased level of robustness to RC wall structures, and allowance has been made to reduce the potential adverse effects associated with actions such as elongation and bi-axial bending. Further research may be required to refine these elements.

References

- Bull, D. (2012). The performance of Concrete Structures in the Canterbury Earthquakes: Lessons for concrete buildings, *Structural Engineers Association of California (SEAOC) Convention*, Santa Fe, NM, USA.
- CERC (2012a). Canterbury Earthquakes Royal Commission Report. Final report: Volume 2: The performance of Christchurch CBD buildings.
- CERC (2012b) Canterbury Earthquakes Royal Commission Report. Final report: Volume 6. Canterbury Television Building (CTV), Nov. 2012, pp196-232
- Cook, D., Fenwick, R. C. and Russell A.P. (2014) Amendment 3 to NZS 3101. *The New Zealand Concrete Industry Conference*, Wairakei Resort, Taupo, New Zealand, 9-11 October
- Henry, R. S. (2013) Assessment of minimum vertical reinforcement limits for RC walls, *Bulletin of the New Zealand Society for Earthquake Engineering*, 46(2), 88-96.
- Holmes Solutions (2011). Material testing in buildings of interest: Gallery Apartments, Westpac Centre and IRD building. <http://canterbury.royalcommission.govt.nz/documents-by-key/20111129.1351>, Report prepared for the Canterbury Earthquakes Royal Commission.
- Kam, W. Y., Pampanin, S. and Elwood, K. J. (2011). Seismic Performance of Reinforced Concrete Buildings in the 22 February Christchurch (Lyttelton) Earthquake, *Bulletin of the New Zealand Society for Earthquake Engineering*, Vol 44(4) 239-278

Lu, Y., Goltom, R., Henry, R. S., Ma, Q. T. (2014). Experimental evaluation of minimum vertical reinforcement requirements for reinforced concrete walls, *Proceedings of the 2014 New Zealand Concrete Industry Conference*, Wairakei, New Zealand, October 9-11, p314-323.

Lu, Y., Henry, R. S., Gultom, R., Ma, Q. T. (2015). Experimental testing and modelling of reinforced concrete walls with minimum vertical reinforcement, *Proceedings of the 2015 NZSEE Annual Conference*, Rotorua, April 10-12.

NZS 3101:2006. Concrete Structures Standard. Wellington, New Zealand, Standards New Zealand: 646.

Paulay, T. (1981). *Design of Reinforced Concrete Shear Walls for Earthquake Resistance*, Civil Engineering, University of Canterbury Research report, 1981

Paulay, T. and Priestley, N. J. M. (1992). *Seismic Design of Reinforced Concrete and Masonry Buildings*, published John Wiley and Sons, New York, 1992, pages 377 and 419.

Paulay, T., (2003). Seismic Displacement Capacity of Ductile Reinforced Concrete Building Systems, *Bulletin of the New Zealand Society for Earthquake Engineering*, 36(1), March 2003, 47- 65

Santhakumar, A. R. (1974). Ductility of Coupled Shear Walls, PhD thesis, University of Canterbury

Smith, P. and England, V. (2012). *Independent assessment on earthquake performance of Gallery Apartments - 62 Gloucester Street*. <http://canterbury.royalcommission.govt.nz/documents-by-key/20120217.3188>, Report prepared for the Canterbury Earthquakes Royal Commission.

Sritharan, S., Beyer, K., Henry, R. S., Chai, Y. H. Kowalsky, M., Bull, D. (2014) Understanding poor seismic performance of concrete walls and design implications, *Earthquake Spectra*, 30(1), 307-334.

Structural Engineering Society of New Zealand (SESOC). (2011). *Preliminary Observations from Christchurch Earthquakes*. <http://canterbury.royalcommission.govt.nz/documents-by-key/20111205.1533>, Report prepared for the Canterbury Earthquakes Royal Commission

Structural Engineering Society of New Zealand (SESOC). (2013). *Interim Design Guidance Design of Conventional Structural Systems Following The Canterbury Earthquakes*. <http://www.sesoc.org.nz/Design-Guides/SESOC-Interim-Design-Guidance-0.9.pdf>

CONCRETE NZ – LEARNED SOCIETY

NZS 3101:2006 AMENDMENT 3



To download the presenters PowerPoint slides in colour (one page per slide format)
use this QR code, or go to

concretesociety.org.nz/q/NZS3101

(QR readers are easily installed at no cost from your mobile phone app store)