



AREVA

Leadership in Safe Used Fuel Transportation

January 12, 2016

Sven Bader, PhD., PE

Advisory Engineer

AREVA Federal Services, LLC

Transportation a Critical Link

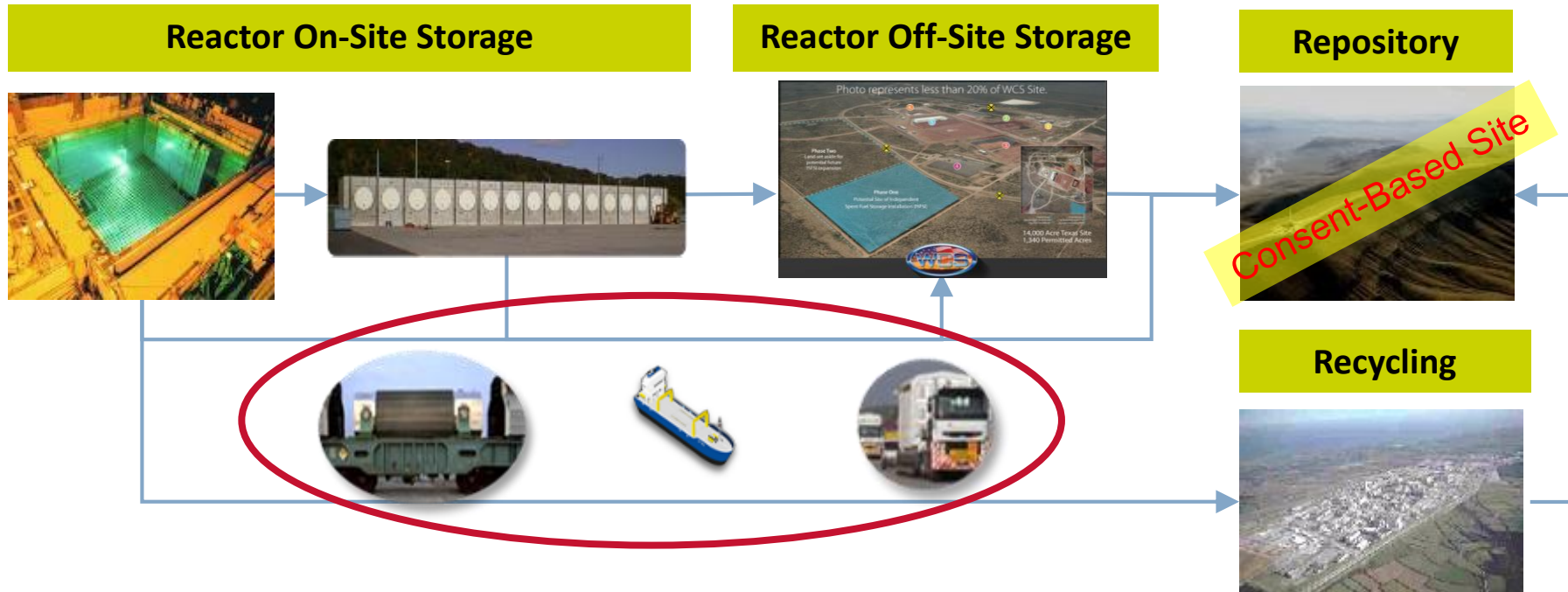

Transportation: a critical element to nearly all aspects of the Spent/Used Fuel Management

AREVA Global Experience: Around 4,000 Shipments Each Year



- ▶ More than 200 shipments of used fuel (France and Europe) and of vitrified and compacted waste (Europe and Japan)
- ▶ More than 150 MOX fuel shipments
- ▶ More than 300 shipments of low level waste
- ▶ More than 2,700 front-end shipments
- ▶ Around 150 shipments for research reactors and laboratories
- ▶ And also more than 400 shipments of heavy industrial equipment

Transportation of UNF is a well understood and demonstrated activity.

AREVA U.S. Transportation Experience

- ▶ Foreign research reactor UNF to Savannah River and Idaho, >250 shipments
- ▶ TN9 cask shipments (1980's): Dresden & Oyster Creek UNF to West Valley
- ▶ TN8 cask shipments (1980's): PWR UNF shipped from Oconee Nuclear Station to McGuire Nuclear Station
- ▶ Numerous post-irradiation examination (PIE) shipments
- ▶ Planning TN32 shipment from North Anna to TBD (~2028)



Transportation of UNF in the U.S. is and has been safely performed.

AREVA has Experience Adapting Equipment to Each Stage of the Nuclear Fuel Cycle



- ▶ **2,200 casks (from 1 to 130 t) with more than 50 heavy-weight casks dedicated to used fuel and vitrified and compacted residues**
- ▶ **47 wagons/railcars dedicated to heavy-weight casks**
- ▶ **100 trucks/trailers designed for heavy packages (10 dedicated to high-security shipments)**

Significant equipment will be needed to transport the >72,000 MT of UNF in the U.S.

AREVA has Unparalleled Experience with Diverse Interfaces for Transportation Packages



Shipment in the U.S. of UNF from the various sites may involve diverse interfaces.

... Including Intermodal Transfers

- ▶ Valognes terminal for transferring from railcar to truck
- ▶ More than 1,000 truck/wagon transfers of packages per year
- ▶ 15 operators, 7 tracks
- ▶ 5 halls for unloading, loading, & radiological control
- ▶ Facility for change of configuration of rail cars
- ▶ 40 km from La Hague site (Reprocessing)

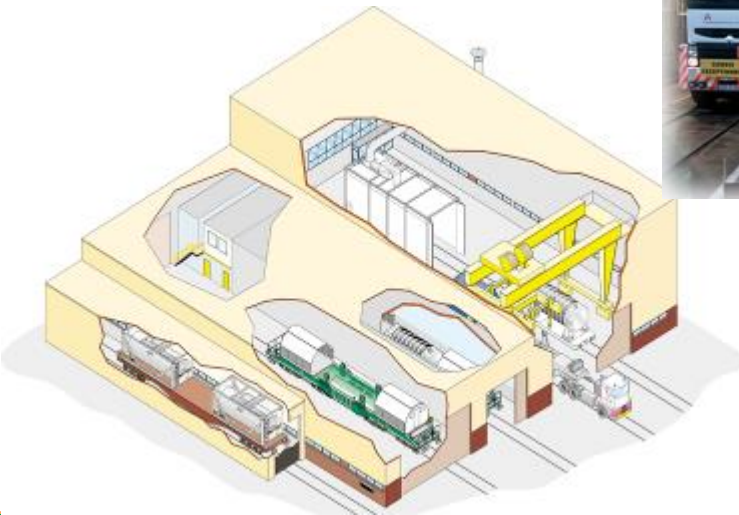

Valognes: the link between La Hague recycling facility and railway network.

AREVA Supporting Current Direction of UNF/SNF Management in the U.S.

Pool

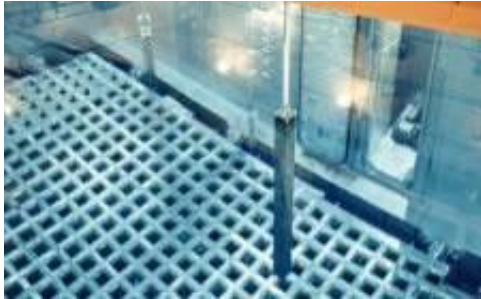

Dry storage multipurpose casks



Dry storage canisters



TN - MP197HB Universal Transport Cask

- ▶ Universal transport package – licensed for nine different canister types
- ▶ Meets NRC requirements to safe transport of high burn-up UNF in canisters
- ▶ Currently being fabricated at Hitachi-Zosen (ready for deployment this year)
- ▶ Elegant, easy, safe transfer of canisters into transportation package
- ▶ No vertical lift of canister necessary
- ▶ High heat-load capacity (up to 32 kW) [61/69 BWR FA or 24/32/37 PWR FA]
- ▶ Approved for use by rail, truck, or marine transport

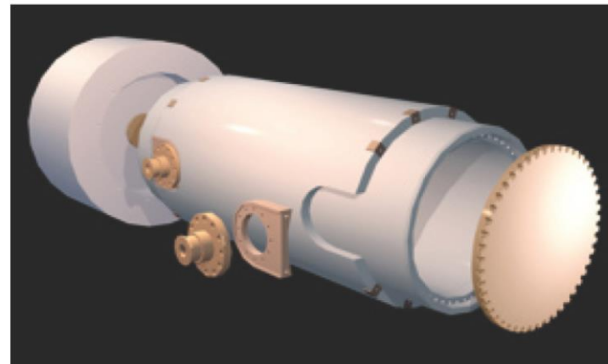
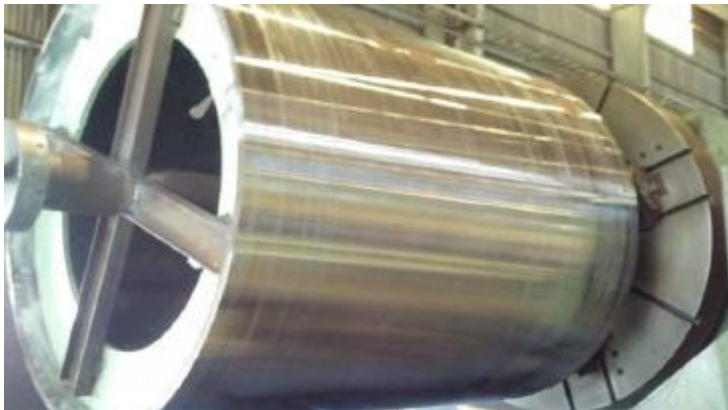

MP197HB Transport Cask



Universal transportation packages reduce costs associated with shipping UNF.

Conceptual Design of a Transportation Package for Uncanistered UNF

- ▶ Reusable transportation package for 61 BWR and 24 PWR UNF
- ▶ Designed to handle short-cooled high burnup UNF (≥ 5 years)
- ▶ Also designed to handle damaged UNF in damaged fuel cans
- ▶ < 125 ton gross hook weight, designed for rail transport
- ▶ Designed to take UNF directly from SFP (no welding, 2 bolted lids)

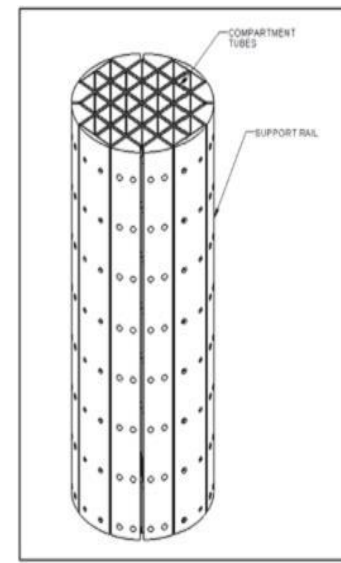
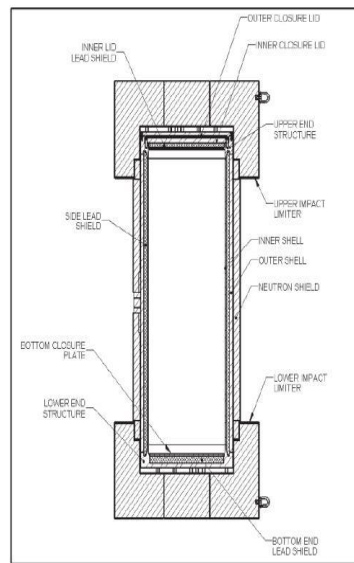
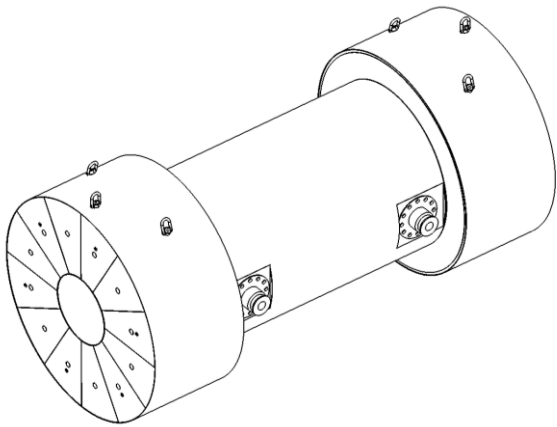

Transportation of uncanistered UNF may be beneficial to DOE and utilities.

AREVA-led Team Railcar Project

► AREVA led-team designing a railcar under a contract with DOE

- ◆ Will meet Association of American Railroads (AAR) Standard 2043
- ◆ Project includes conceptual cradle designs for DOE selected licensed transport packages

(Subject of presentation Wednesday afternoon)

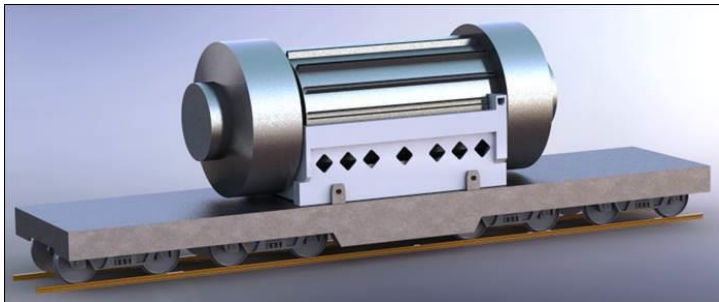

Drawings are conceptual.

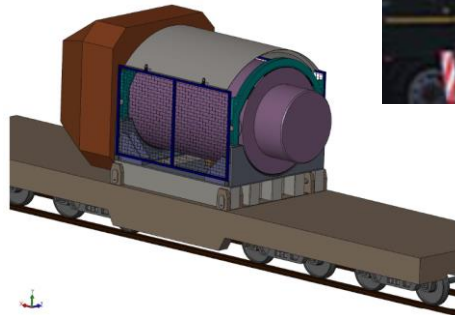
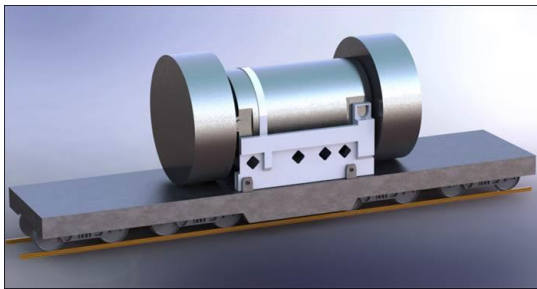

A railcar approved to AAR standards is a critical element to UNF transport in the U.S.

AREVA-led Team Developing Initial Site-Specific Deinventory Implementation Plan

- ▶ Focus has been to provide UT-Battelle (ORNL) industrial feedback/information on potential de-inventory activities at select sites with shutdown reactors
- ▶ Identify tasks and interfaces necessary to perform activity
 - ◆ Near-site transportation infrastructure and routes to rail-sidings or spurs
 - ◆ Identification of entities involved in preparing for, conducting & demobilizing the campaign
 - ◆ Potential significant effort will be required to move stranded UNF from ISFSIs to Class I rail carrier/barge due to loss of infrastructure at sites



High Burnup Dry Storage Cask Research & Development Project

- ▶ TN-32 cask with lid modified to allow insertion of temp. probes
- ▶ Provide confirmatory data, including for transportation of HBU
- ▶ TN cask to be transported to an off-site fuel examination facility
(Subject of presentation Wednesday afternoon)

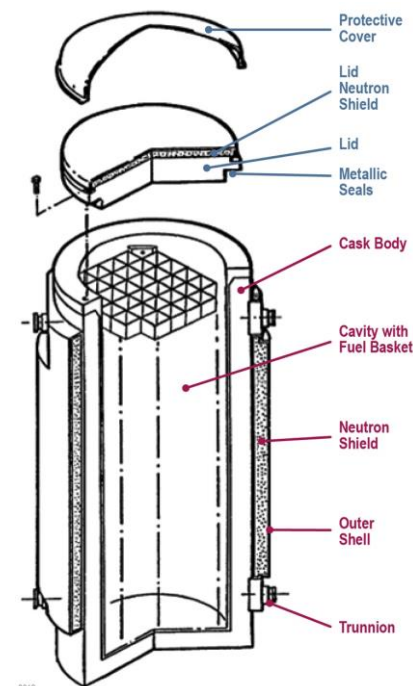

Providing certainty toward shipment of HBU UNF.

The La Hague Advantage

- ▶ Shipment of ~3,000 fuel assemblies per year (> 75,000 total)
- ▶ Capable of unloading casks in both dry (250 casks/yr) and wet (130 casks/yr) facilities
- ▶ 3,363 cask received (1/2000 – 6/2014)
- ▶ 1,080 damaged & 229 failed fuel assemblies received since 2000
- ▶ No damage to UNF during transportation or during unloading
- ▶ Unloading includes short-cooled HBU UNF

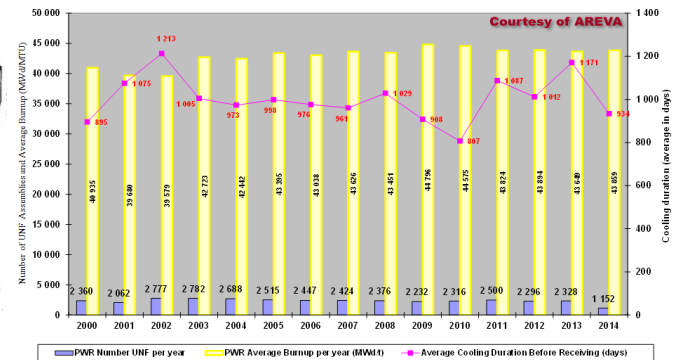
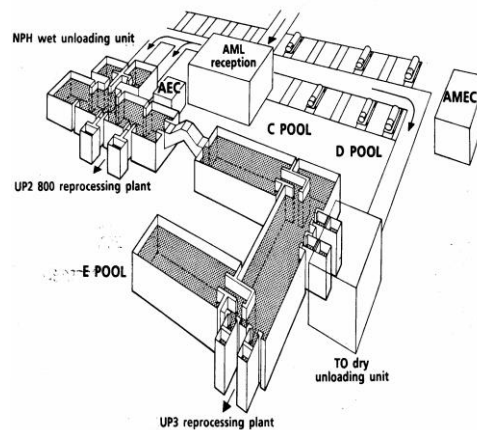
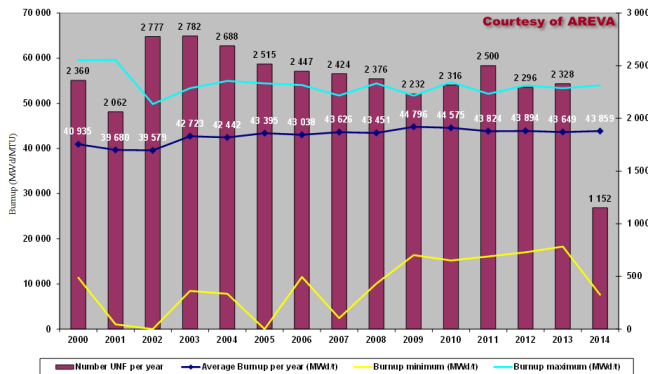

Demonstrating the safe transportation, receipt, and handling of UNF.

Summary

- ▶ **Globally AREVA provides demonstrated safe and secure transportation of nuclear materials, including shipment of short-cooled HBU**
- ▶ **Experience adapting equipment to each stage of the nuclear fuel cycle**
- ▶ **Unparalleled experience with diverse interfaces for transportation packages, including intermodal transfers**
- ▶ **Providing support for “current” direction of U.S. fuel management**
 - ◆ **TN MP197HB**
 - ◆ **Railcar**
 - ◆ **Deinventory**

Public outreach is an industry priority. We share a collective responsibility for promoting safe transportation systems.

Questions?

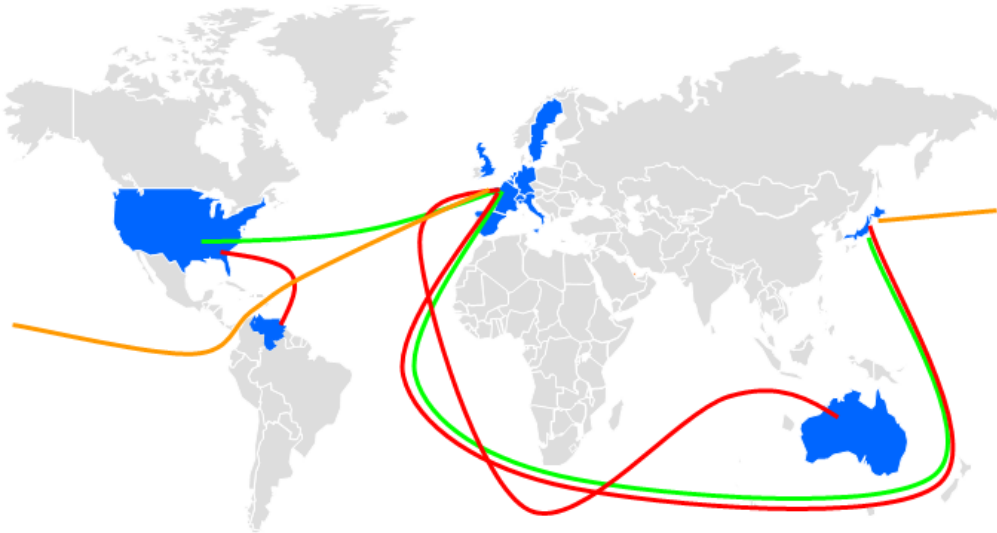

Used Fuel	MOX
Waste	REPU

Main steps of used fuel transport in Europe (1/4)



Reactor site



**After cask loading,
transfer onto
transport equipment**



**If no rail spur, road
transport to nearest
spur and then rail
transport**

Main steps of used fuel transport in Europe (2/4)



EDF Railway terminal



Transport by rail



Valognes Railway Terminal

Main steps of used fuel transport in Europe (3/4)



Road transport
between Valognes –
La Hague



Reception of cask at
La Hague

Main steps of used fuel transport in Europe (4/4)

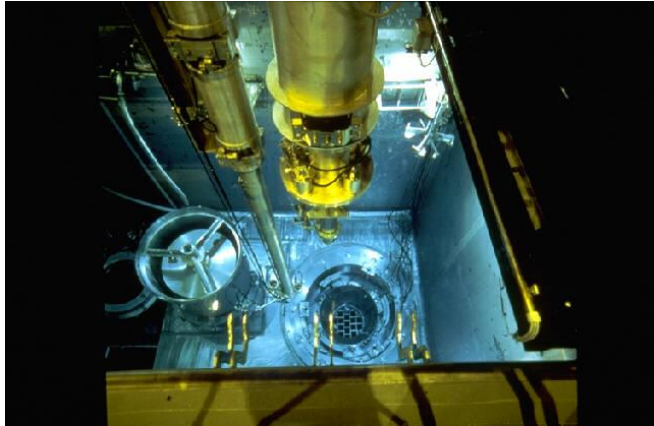

Wet or dry
unloading at La
Hague



Storage pool at La
Hague

Empty cask parking
at La Hague



» Q70



» Q76

Fuel Loading Maps for Conceptual Design of a Transportation Package



Maximum Burnup	Minimum Enrichment	Minimum Cooling Time (years)		
		Zone 1/4	Zone	Zone
		Heat \leq 0.9 kW	Heat \leq 1.4 kW	Heat \leq 2.1 kW
\leq 30	\geq 1.8	\geq 5	\geq 5	\geq 5
\leq 37	\geq 2.3	\geq 6.5	\geq 5	\geq 5
\leq 45	\geq 2.8	\geq 10	\geq 5	\geq 5
\leq 53	\geq 3.3	\geq 16	\geq 6.5	\geq 5
\leq 62.5	\geq 3.8	\geq 26	\geq 9	\geq 5

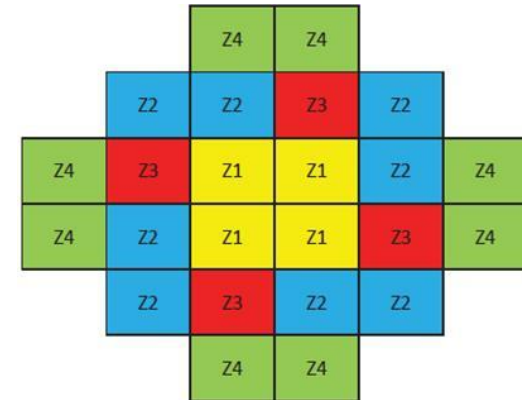

Maximum Burnup	Minimum Enrichment	Minimum Cooling Time (years)		
		Zone 1/4	Zone	Zone
		Heat \leq 0.33 kW	Heat \leq 0.78 kW	Heat \leq 0.45 kW
\leq 29	\geq 1.5	\geq 5	\geq 5	\geq 5
\leq 35	\geq 2.2	\geq 6	\geq 5	\geq 5
\leq 39	\geq 2.4	\geq 7.2	\geq 5	\geq 5
\leq 45	\geq 2.8	\geq 10	\geq 5	\geq 6
\leq 53	\geq 3.3	\geq 16	\geq 5	\geq 8
\leq 62.5	\geq 3.8	\geq 25	\geq 5	\geq 12.5

