

# NFRC 201-2023<sub>[E0A0]</sub>

Procedure for Interim Standard  
Test Method for Measuring the  
Solar Heat Gain Coefficient of  
Fenestration Systems Using  
Calorimetry Hot Box Methods

---

© 2013, 2023 National  
Fenestration Rating Council, Inc.

**Prepared by:**

**National Fenestration Rating Council**

6305 Ivy Lane, Suite 410

Greenbelt, MD 20770

P: 301-589-1776

F: 301-589-3884

E: [info@nfr.org](mailto:info@nfr.org)

W: [www.nfr.org](http://www.nfr.org)





## ***FOREWORD***

The National Fenestration Rating Council, Incorporated (NFRC) has developed and operates a uniform rating system for energy and energy-related performance of fenestration products. The Rating System determines the U-factor, Solar Heat Gain Coefficient (SHGC) and Visible Transmittance (VT) of a product, which are mandatory ratings for labeling NFRC certified products, are mandatory ratings for inclusion on label certificates, and are supplemented by procedures for voluntary ratings of products for Air Leakage (AL), and Condensation Resistance. Together, these rating procedures, as set forth in documents published by NFRC, are known as the NFRC Rating System.

The NFRC Rating System employs computer simulation and physical testing by NFRC-accredited laboratories to establish energy and related performance ratings for fenestration product types. The NFRC Rating System is reinforced by a certification program under which NFRC-licensed responsible parties claiming NFRC product certification shall label and certify fenestration products to indicate those energy and related performance ratings, provided the ratings are authorized for certification by an NFRC-licensed certification and Inspection Agency (IA).

The requirements of the rating, certification, and labeling program (Certification Program) are set forth in the most recent versions of the following as amended, updated, or interpreted from time to time:

- NFRC 700 Product Certification Program (PCP).
- NFRC 705 Component Modeling Approach (CMA), Product Certification Program (CMA-PCP).

Through the Certification Program and the most recent versions of its companion programs as amended, updated, or interpreted from time to time:

- The laboratory accreditation program (Accreditation Program), as set forth in the NFRC 701 Laboratory Accreditation Program (LAP).
- The IA licensing program (IA Program), as set forth in NFRC 702 Certification Agency Program (CAP).
- The CMA Approved Calculation Entity (ACE) licensing program (ACE Program), as set forth in the NFRC 708 Calculation Entity Approval Program (CEAP).

NFRC intends to ensure the integrity and uniformity of NFRC ratings, certification, and labeling by ensuring that responsible parties, testing and simulation laboratories, and IAs adhere to strict NFRC requirements.

In order to participate in the Certification Program, a Manufacturer/Responsible Party shall rate a product whose energy and energy-related performance characteristics are to be certified in accordance with mandatory NFRC rating procedures. At present, a Manufacturer/Responsible Party may elect to rate products for U-factor, SHGC, VT, AL, Condensation Resistance, or any other procedure adopted by NFRC, and to include those ratings on the NFRC temporary label affixed to its products, or on the NFRC Label Certificate. U-factor, SHGC and VT, AL, and Condensation Resistance rating reports shall be obtained from a laboratory that has been accredited by NFRC in accordance with the requirements of the NFRC 701.

The rating shall then be reviewed by an IA which has been licensed by NFRC in accordance with the requirements of the NFRC 702. NFRC-licensed IAs also review label format and content, conduct in-plant inspections for quality assurance in accordance with the requirements of the NFRC 702, and issue a product Certification Authorization Report (CAR), or approve for issuance an NFRC Label Certificate for site-built or CMA products and attachment products. The IA is also responsible for the investigation of potential violations (prohibited activities) as set forth in the NFRC 707 Compliance and Monitoring Program (CAMP).

Ratings for products that are labeled with the NFRC Temporary and Permanent Label, or products that are listed on an NFRC Label Certificate in accordance with NFRC requirements, are considered to be NFRC-certified. NFRC maintains a Certified Products Directory (CPD), listing product lines and individual products selected by the manufacturer/responsible party for which certification authorization has been granted.

NFRC manages the Rating System and regulates the Product Certification Program (PCP), Laboratory Accreditation Program (LAP) and Certification Agency Program (CAP) in accordance with the NFRC 700 (PCP), the NFRC 701 (LAP), the NFRC 702 (CAP), the NFRC 705 (CMA-PCP), and the NFRC 708 (CEAP) procedures, and conducts compliance activities under all these programs as well as the NFRC 707 (CAMP). NFRC continues to develop the Rating System and each of the programs.

NFRC owns all rights in and to each of the NFRC 700, NFRC 701, NFRC 702, NFRC 705, NFRC 707, NFRC 708 and each procedure, which is a component of the Rating System, as well as each of its registration marks, trade names, and other intellectual property.

The structure of the NFRC program and relationships among participants are shown in Figure 1, Figure 2, and Figure 3. For additional information on the roles of the IAs and laboratories and operation of the IA Program and Accreditation Program, see the NFRC 700 (PCP), NFRC 701 (LAP), and NFRC 702 (CAP) respectively.

**Figure 1**

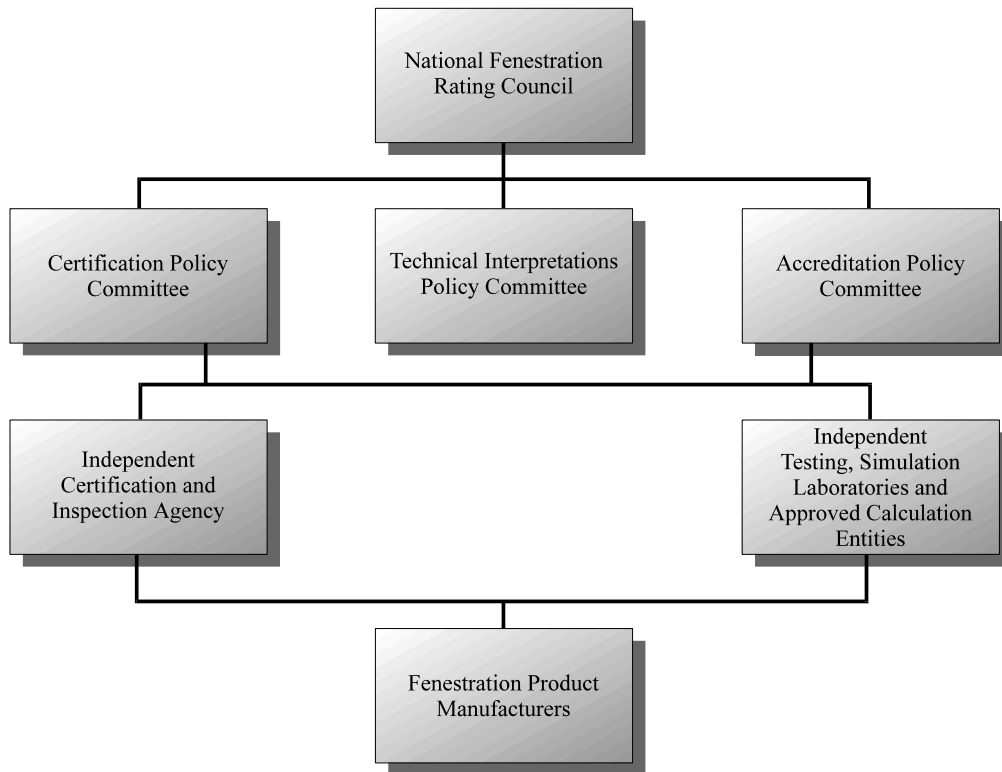

**Figure 2**

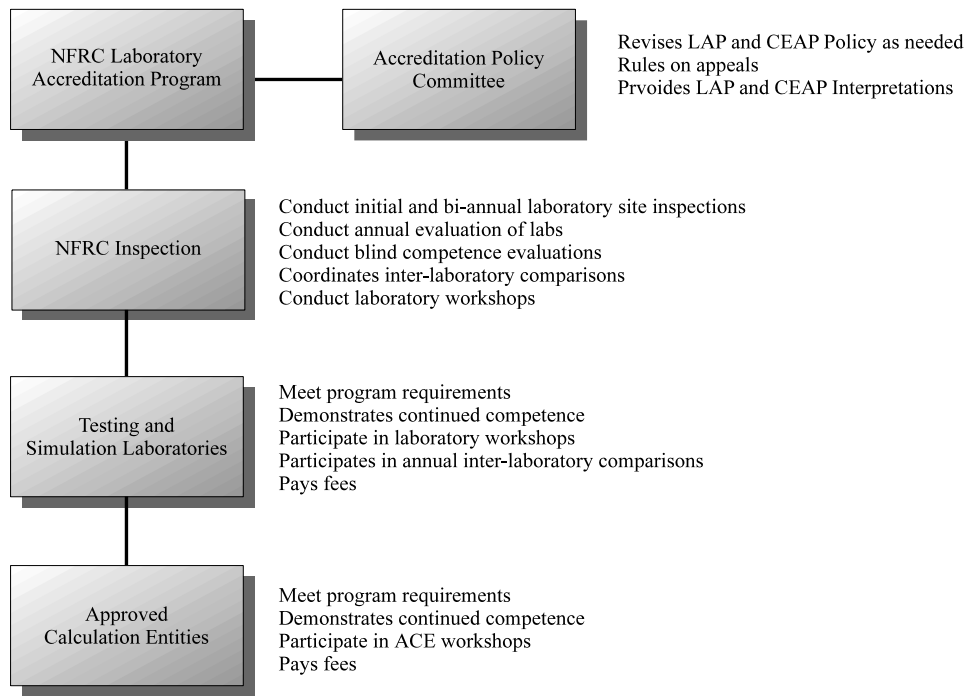

**Figure 3**

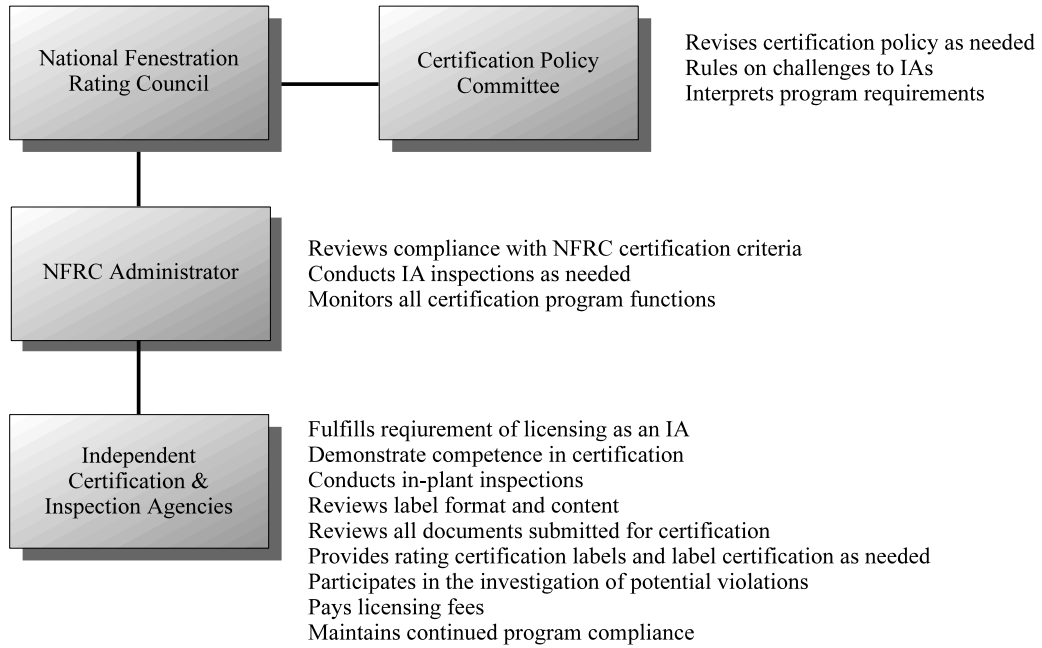

Questions on the use of this procedure should be addressed to:

**National Fenestration Rating Council**  
6305 Ivy Lane, Suite 410  
Greenbelt, MD 20770  
Voice: (301) 589-1776  
Fax: (301) 589-3884  
Email: [info@nfrc.org](mailto:info@nfrc.org)  
Website: [www.nfrc.org](http://www.nfrc.org)



## ***DISCLAIMER***

NFRC certification is the authorized act of a Manufacturer/Responsible Party in: (a) labeling a fenestration or related attachment product with an NFRC Permanent Label and NFRC Temporary Label, or (b) generating a site built or CMA label certificate, either of which bears one or more energy performance ratings reported by NFRC-accredited simulation and testing laboratories and authorized for certification by an NFRC-licensed IA. Each of these participants acts independently to report, authorize certification, and certify the energy-related ratings of fenestration and related attachment products.

NFRC does not certify a product and certification does not constitute a warranty of NFRC regarding any characteristic of a fenestration or fenestration-related attachment product. Certification is not an endorsement of or recommendation for any product or product line or any attribute of a product or product line. NFRC is not a merchant in the business of selling fenestration products or fenestration-related products, and therefore cannot warrant products as to their merchantability or fitness for a particular use.

NFRC THEREFORE DISCLAIMS ANY AND ALL LIABILITY THAT MAY ARISE FROM OR IN CONNECTION WITH SERVICES PROVIDED BY, DECISIONS MADE BY OR REPORTS OR CERTIFICATIONS ISSUED OR GRANTED BY ANY NFRC-ACCREDITED LABORATORY, NFRC-LICENSED IA OR ANY PRODUCT MANUFACTURER/RESPONSIBLE PARTY; RELIANCE ON ANY NFRC PRODUCT DESCRIPTION, SPECIFICATION, RATING, TEST OR CERTIFICATION, WHETHER APPEARING IN A REPORT, A PRODUCT CERTIFICATION AUTHORIZATION OR A PRINTED OR ELECTRONIC DIRECTORY, OR ON A LABEL, OR ON A LABEL CERTIFICATE; OR THE SALE OR USE OF ANY NFRC-RATED OR CERTIFIED PRODUCT OR PRODUCT LINE; INCLUDING BUT NOT LIMITED TO DAMAGES FOR PERSONAL OR OTHER INJURY, LOST PROFITS, LOST SAVINGS OR OTHER CONSEQUENTIAL OR INCIDENTAL DAMAGES.

NFRC program participants are required to indemnify NFRC from and against such liability.



## Table of Contents

<b>Forward</b>		<b>ii</b>
<b>Disclaimer</b>		<b>vi</b>
<b>Foreword</b>		<b>i</b>
<b>Disclaimer</b>		<b>v</b>
<b>1. Scope</b>		<b>1</b>
<b>2. Referenced Documents</b>		<b>1</b>
2.1	ASTM STANDARDS	1
2.1	ASHRAE/ANSI STANDARDS	3
2.3	NFRC STANDARDS	3
2.4	ISO STANDARDS	3
<b>3. Terminology</b>		<b><u>43</u></b>
3.1	DEFINITIONS	<u>43</u>
3.2	DESCRIPTIONS OF TERMS SPECIFIC TO THIS STANDARD:	<u>54</u>
3.3	SYMBOLS	<u>76</u>
<b>4. Significance and Use</b>		<b><u>109</u></b>
<b>5. Calibration</b>		<b><u>1413</u></b>
5.1	OVERALL CALIBRATION REQUIREMENTS	<u>1413</u>
	Table 5-1 – Calibrations Required	14
5.2	INSTRUMENT CALIBRATION	15

5.2.1	Pyranometer Calibration .....	15
5.2.2	Fluid Temperature Difference.....	<u>1615</u>
5.2.3	Fluid Flow Rate.....	<u>1615</u>
5.3	SYSTEM CHARACTERIZATION .....	16
5.3.1	Temperature Measurements .....	16
5.3.1.1	Interior Surface Temperatures .....	16
5.3.1.2	Surface Temperature Difference .....	16
5.3.1.3	Air Temperatures.....	<u>1716</u>
5.3.1.4	Fluid Temperature Difference.....	17
5.3.1.5	Fluid Flow Rate Measurements .....	<u>1817</u>
5.3.2	Miscellaneous Power Input.....	18
5.3.3	Irradiance Measurements .....	18
5.4	SYSTEM CHARACTERIZATION TESTS.....	18
5.4.1	General System Calibration Requirements.....	<u>1918</u>
5.4.1.1	Calibration Panel or Surround Panel.....	<u>1918</u>
5.4.1.2	Air Leakage .....	<u>1918</u>
5.4.1.3	Heat Input Measurement and Instrumentation .....	19
5.4.2	Calibration of Solar Calorimeter Wall Heat Flux.....	<u>2019</u>
5.4.3	Surround Panel Flanking Loss Calibration.....	20
5.4.4	Time Constant Determination.....	20
5.5	SYSTEM VERIFICATION TESTS.....	<u>2120</u>
5.5.1	Internal Surface Heat Transfer Coefficient.....	<u>2120</u>
5.5.2	Real System Tests.....	21
5.5.2.1	General Description .....	21
<b>6.</b>	<b>Experimental Apparatus and Instrumentation.....</b>	<b><u>2322</u></b>
6.1	GENERAL DESCRIPTION OF MEASUREMENT OF SOLAR HEAT GAIN COEFFICIENT.....	<u>2322</u>
	Figure 6-1 -- Typical components used in a calorimeter apparatus.....	23
6.2	DESCRIPTION OF SOLAR CALORIMETER CELL .....	24
6.2.1	Design Options .....	24
6.2.1.1	Tracking vs. Stationary .....	<u>2524</u>
6.2.1.2	Guarded vs. Calibrated .....	<u>2524</u>
6.2.1.3	Dynamic vs. Steady-state .....	25
6.2.2	Solar Calorimeter Wall Construction, Absorber Plate and Instrumentation.....	25
6.2.2.1	Interior Air Temperature Instrumentation .....	<u>2625</u>
6.2.2.2	Interior Air Temperature Control .....	<u>2726</u>
6.2.2.3	External Electrical Power Instrumentation .....	27
6.2.2.4	Interior Solar Calorimeter Walls and Absorber Plate..	27
6.2.2.5	Insulated Walls of Solar Calorimeter .....	28
6.2.2.6	Guarded Solar Calorimeter.....	<u>2928</u>
	Figure 6-2 -- Cross Section of Solar Calorimeter Wall Using Electric Heater Guard.....	29

	Figure 6-3 -- Schematic of Actively Guarded Solar Calorimeter Using Fluid Heater Guard .....	<u>3029</u>
	6.2.2.7 Exterior Shell of Solar Calorimeter .....	30
6.2.3	Surround Panel and Instrumentation .....	<u>3130</u>
6.2.4	Heat Extraction System and Instrumentation .....	<u>3130</u>
	Equation 6-1 .....	<u>3130</u>
	6.2.4.1 Fluid Temperatures .....	<u>3231</u>
	6.2.4.2 Flow Measurements.....	<u>3231</u>
6.2.5	Automated Systems for Tracking Solar Calorimeter Tilt and Azimuth .....	<u>3231</u>
6.3	SOLAR RADIATION MEASUREMENT .....	<u>3231</u>
6.3.1	Radiometer Requirements.....	<u>3332</u>
	6.3.1.1 Variation with Ambient Temperature.....	<u>3432</u>
	6.3.1.2 Variation in Spectral Response.....	<u>3432</u>
	6.3.1.3 Nonlinearity of Response .....	<u>3432</u>
	6.3.1.4 Time Constant.....	<u>3432</u>
	6.3.1.5 Variation with Angle of Incidence.....	<u>3432</u>
	6.3.1.6 Variation with Tilt .....	<u>3533</u>
	6.3.1.7 Effects of Temperature Gradient .....	<u>3533</u>
	6.3.1.8 Calibration .....	<u>3533</u>
	6.3.1.9 Sample Plane Pyranometer.....	<u>3533</u>
	6.3.1.10 Horizontal Pyranometer .....	<u>3533</u>
6.4	MEASUREMENT OF AMBIENT CONDITIONS .....	<u>3533</u>
6.4.1	Exterior Air Temperature Instrumentation .....	<u>3534</u>
6.4.2	Wind Speed and Direction .....	<u>3634</u>
6.4.3	Measured Weather Side Surface Heat Transfer Coefficient.....	<u>3634</u>
<b>7.</b>	<b>Test Procedure .....</b>	<b><u>3634</u></b>
7.1	TEST SPECIMEN INSTALLATION .....	<u>3634</u>
	7.1.1 Test Specimen Preparation .....	<u>3634</u>
	7.1.2 Test Specimen Installation.....	<u>3635</u>
	7.1.3 Test Specimen Air Leakage .....	<u>3735</u>
	7.1.4 Test Specimen Instrumentation .....	<u>3836</u>
	7.1.5 Test Specimen Average Surface Temperature.....	<u>3836</u>
	7.1.6 Test Specimen Thermal Transmittance.....	<u>3937</u>
7.2	TEST CONDITIONS.....	<u>3938</u>
	7.2.1 General .....	<u>4038</u>
	7.2.2 Incident Solar Irradiation .....	<u>4038</u>
	7.2.2.1 Incident Angle Tolerance .....	<u>4038</u>
	7.2.2.2 Indoor Light Source (Artificial Sunlight) .....	<u>4038</u>
	7.2.3 Ambient Temperature.....	<u>4139</u>
	7.2.3.1 Indoor Solar Calorimeter Ambient Temperature .....	<u>4139</u>
	7.2.4 Exterior Wind Conditions .....	<u>4139</u>
	7.2.4.1 Indoor Solar Calorimeter Exterior Wind Conditions .....	<u>4139</u>

	7.2.4.2 Outdoor Solar Calorimeter Exterior Wind Conditions	
	<u>4139</u>	
	7.2.5 Interior Conditions Inside Solar Calorimeter .....	<u>4240</u>
	7.2.6 Fluid Flow Heat Extraction and Control .....	<u>4240</u>
7.3	DETERMINATION OF STEADY-STATE CONDITIONS .....	<u>4240</u>
<b>8.</b>	<b>Calculation Procedure .....</b>	<b><u>4341</u></b>
8.1	GENERAL DESCRIPTION OF CALCULATION PROCEDURE .....	<u>4341</u>
	Equation 8-1 .....	<u>4341</u>
8.2	HEAT TRANSFER THROUGH SOLAR CALORIMETER SHELL .....	<u>4442</u>
	8.2.1 Solar Calorimeter Walls, $Q_{Walls}$ .....	<u>4442</u>
	8.2.2 Surround Panel, $Q_{SP}$ .....	<u>4442</u>
	8.2.3 Flanking Loss, $Q_{fl}$ .....	<u>4543</u>
8.3	HEAT REMOVAL BY FLUID HEAT EXTRACTION SYSTEM .....	<u>4543</u>
	8.3.1 Fluid Heat Extraction System, $Q_{fluid}$ .....	<u>4543</u>
8.4	HEAT INPUT BY FANS AND PUMPS .....	<u>4543</u>
	8.4.1 Heat Input by Fans and Pumps, $Q_{AUX}$ .....	<u>4543</u>
8.5	HEAT TRANSFER THROUGH THE TEST SPECIMEN, $Q_{U-FACTOR}$ .....	<u>4644</u>
	8.5.1 Standardized Thermal Transmittance, $U_{ST}$ .....	<u>4644</u>
	8.5.1.1 Modified Thermal Transmittance, $U_M$ .....	<u>4745</u>
	8.5.1.2 Measured Weather Side Surface Heat Transfer Coefficient, $h_{h-sun}$ .....	<u>4745</u>
	Equation 8-9 .....	<u>4745</u>
	8.5.1.3 Total Measured Thermal Transmittance .....	<u>4846</u>
	Equation 8-10 .....	<u>4846</u>
8.6	SOLAR IRRADIATION INCIDENT ON THE TEST SPECIMEN, $E_s$ .....	<u>4846</u>
8.7	CALCULATION OF SOLAR HEAT GAIN COEFFICIENT .....	<u>4947</u>
	8.7.1 Data Collection and Analysis .....	<u>4947</u>
	8.7.1.1 Heat Balance Equation, $Q_s$ .....	<u>4947</u>
	8.7.1.2 Calculation of Solar Heat Gain Coefficient, SHGC .....	<u>4947</u>
<b>9.</b>	<b>Test Report .....</b>	<b><u>4947</u></b>
	9.1 REPORTED DATA .....	<u>4947</u>
	9.2 UNCERTAINTY ESTIMATION .....	<u>4947</u>
<b>10.</b>	<b>Precision and Bias .....</b>	<b><u>5048</u></b>
<b>11.</b>	<b>Keywords .....</b>	<b><u>5048</u></b>
	<b>ANNEXES (Mandatory Information) .....</b>	<b><u>5149</u></b>
<b>A.</b>	<b>Solar-Air Heat Transfer Coefficient Meter .....</b>	<b><u>5149</u></b>
A1.	DESCRIPTION OF SOLAR-AIR HEAT TRANSFER COEFFICIENT METER .....	<u>5149</u>
A2.	CONSTRUCTION AND INSTALLATION OF SOLAR-AIR HEAT TRANSFER COEFFICIENT METER .....	<u>5149</u>
	A2.1 General Description .....	<u>5149</u>
	Figure 11-1 -- Solar-Air Heat Transfer Coefficient Meter .....	<u>5250</u>

A2.2	Metal Plate and Instrumentation .....	<u>5250</u>
A2.2.1	Aluminum Plate .....	<u>5250</u>
Figure 11-2	-- Thermocouple attached to back side of aluminum plate .....	<u>5351</u>
A2.2.2	Copper Plate .....	<u>5351</u>
A2.3	Foam Insulation .....	<u>5452</u>
A2.4	Installation .....	<u>5452</u>
<b>B.</b>	<b>Calibration of Solar Calorimeter Wall Heat Flux.....</b>	<b><u>5452</u></b>
B1.	CALIBRATION OF SOLAR CALORIMETER WALL HEAT FLUX .....	<u>5452</u>
B2.	MODEL PREDICTION.....	<u>5553</u>
Equation 11-1	.....	<u>5553</u>
Equation 11-2	.....	<u>5553</u>
B3.	SOLAR CALORIMETER CALIBRATION .....	<u>5654</u>
B4.	VERIFYING CALORIMETER WALL TRANSDUCER NULL OFFSET .....	<u>5654</u>
B5.	CALIBRATION OF CALORIMETER WALL TRANSDUCER.....	<u>5755</u>
<b>C.</b>	<b>Surround Panel Flanking Loss Calibration.....</b>	<b><u>5856</u></b>
C1.	CALIBRATION OF SURROUND PANEL FLANKING HEAT FLUX .....	<u>5856</u>
Equation 11-3	.....	<u>5957</u>
<b>D.</b>	<b>Recommended Practice for Estimation of the Testing System Time Constant .....</b>	<b><u>5957</u></b>
D1.	GENERAL CONSIDERATIONS.....	<u>5957</u>
D2.	TESTING SYSTEM TIME CONSTANT EVALUATION .....	<u>6058</u>
D3.	RESPONSE OF THE APPARATUS .....	<u>6058</u>
D3.1	Experimental Determination of the Apparatus Time Constant	
	<u>6159</u>	
D3.2	Procedure for Experimental Time Constant Determination...	<u>6260</u>
D4.	CALCULATION OF SPECIMEN TIME CONSTANTS.....	<u>6462</u>
Equation 11-4	.....	<u>6462</u>
Equation 11-5	.....	<u>6462</u>
Equation 11-6	.....	<u>6563</u>
D5.	OVERALL TEST TIME CONSTANT .....	<u>6563</u>
D5.1	Alternative Methods .....	<u>6563</u>
<b>E.</b>	<b>Calibration Transfer Standard Tests.....</b>	<b><u>6664</u></b>
Figure 11-3	.....	<u>6664</u>
<b>F.</b>	<b>Design and Construction of the Solar Calorimeter Calibration and Surround Panels.....</b>	<b><u>6765</u></b>
F1.	CONSTRUCTION AND INSTRUMENTATION OF THE PANELS.....	<u>6765</u>
F2.	SURROUND PANELS.....	<u>6866</u>
F3.	INSTRUMENTATION OF CALIBRATION AND SURROUND PANELS.....	<u>6967</u>
F4.	CALIBRATION OF THE PANEL AS A HEAT FLOW TRANSDUCER .....	<u>7169</u>

<b>G. Tubular Daylighting Device (TDD) Installation and Testing .....</b>	<b><u>7270</u></b>
G1. TDD INSTALLATION.....	<u>7270</u>
G2. TDD TESTING .....	<u>7270</u>
<b>References .....</b>	<b><u>7472</u></b>
<b>Index .....</b>	<b><u>7573</u></b>

- 
- 1. SCOPE**
- A. This test method provides requirements and guidelines and specifies calibration procedures required for the measurement of the Solar Heat Gain Coefficient (SHGC) of fenestration systems and glazing systems installed in a solar calorimeter (hot box).
  - B. This test method applies to all fenestration systems, glazed apertures in buildings intended for the controlled admission of solar radiation. This includes windows, glazed doors, translucent panels, skylights and glazing systems incorporating integral or attached shading devices such as insect screens, drapes, shades and blinds. Annex G describes how this test method can be used to measure the SHGC of Tubular Daylighting Devices (TDD).  
  
[Note: The methods described in this document may also be adapted for use in determining the SHGC of sections of totally opaque building wall, roof and floor assemblies containing thermal anomalies, which are smaller than the solar calorimeter metering area, but the results cannot be NFRC certified.]
  - C. This test method specifies the necessary measurements to be made using solar calorimeters exposed to solar radiation under clear sky conditions (outdoors) or using artificial solar radiation (indoors). The test sample may be illuminated with either direct beam radiation only or with direct beam plus diffuse sky and ground reflected radiation, as long as the method of irradiation is specified and the method employed satisfies the specifications within this document.
  - D. A discussion of the terminology and underlying assumptions for measuring the Solar Heat Gain Coefficient is included.
  - E. This standard does not purport to address all of the safety problems, if any, associated with its use. It is the responsibility of the user of this standard to establish appropriate safety and health practices and determine the applicability of regulatory limitations prior to use.
- 2. REFERENCED DOCUMENTS**

---

### 2.1 ASTM Standards

- C 168 Terminology Relating to Thermal Insulating Materials, Annual Book of ASTM Standards, Vol. 04.06

- C 177 Test Method for Steady-State Heat Flux Measurements and Thermal Transmission Properties by Means of the Guarded Hot Plate Apparatus, Annual Book of ASTM Standards, Vol.4.11.
- C 518 Test Method for Steady-State Thermal Heat Flux Measurements and Transmission Properties by Means of the Heat Flow Meter Apparatus, Annual Book of ASTM Standards, Vol. 04.11.
- C 1045 Practice for Calculated Thermal Transmission Properties from Steady-State Heat Flux Measurements, Annual Book of ASTM Standards, Vol. 04.11.
- C 1114 Test Method for Steady-State Thermal Transmission Properties by Means of the Thin-Heater Apparatus, Annual Book of ASTM Standards, Vol. 04.11.
- C 1199 Test Method for Measuring the Steady-State Thermal Transmittance of Fenestration Systems Using Hot Box Methods, Annual Book of ASTM Standards, Vol. 04.11.
- C 1363 Standard Method of Test for The Thermal Performance of Building Assemblies by Means of A Hot Box Apparatus, Annual Book of ASTM Standards, Vol. 04.11.
- C 1371 Standard Test Method for Determination of Emittance of Materials Near Room Temperature Using Portable Emissometers, Annual Book of ASTM Standards, Vol. 04.11.
- E 283 Test Method for Rate of Air Leakage Through Exterior Windows, Curtain Walls and Doors Under Specified Pressure Difference Across the Specimen, Annual Book of ASTM Standards, Vol. 04.11.
- E 631 Terminology of Building Constructions. Annual Book of ASTM Standards, Vol. 12.02.
- E 772 Terminology Relating to Solar Energy Conversion, Annual Book of ASTM Standards, Vol. 12.02.
- E 824 Test Method for Transfer of Calibration from Reference to Field Radiometers, Annual Book of ASTM Standards, Vol. 14.04.
- E 1423 Practice for Determining the Steady-State Thermal Transmittance of Fenestration Systems, Annual Book of ASTM Standards, Vol. 12.02.

## 2.2 ASHRAE/ANSI Standards

41.1-1991 Standard Method for Temperature Measurement. Available from ASHRAE Inc.

93-1986 Methods of Testing to Determine the Thermal Performance of Solar Collectors. Available from ASHRAE Inc.

2020 Handbook --of Fundamentals

## 2.3 NFRC Standards

ANSI/NFRC 100 Procedure for Determining Fenestration Product U-Factors. Available from the National Fenestration Rating Council.

ANSI/NFRC 200 Procedure for Determining Fenestration Product Solar Heat Gain Coefficient and Visible Transmittance at Normal Incidence. Available from the National Fenestration Rating Council.

NFRC 300 Test Method for Determining the Solar Optical Properties of Glazing Materials and Systems. Available from the National Fenestration Rating Council.

NFRC 301 Standard Test Method for Emittance of Specular Surfaces Using Spectrometric Measurements

## 2.4 ISO Standards

ISO 9060 Solar Energy – Specification And Classification Of Instruments For Measuring Hemispherical Solar And Direct Solar Radiation. Available from ASHRAE Inc.

ISO 15099 Thermal Performance of Windows, Doors and Shading Devices — Detailed Calculations. Available from ASHRAE Inc.

[ISO 9050](#) [Glass in building — Determination of light transmittance, solar direct transmittance, total solar energy transmittance, ultraviolet transmittance and related glazing factors](#)

[ISO 19467](#) [Thermal performance of windows and doors – Determination of solar heat gain coefficient using solar simulator.](#)

[ISO 19467-2](#) [Thermal performance of windows and doors – Determination of solar heat gain coefficient using solar simulator. – Part 2: Centre of glazing](#)

### 3.1 Definitions

3. **TERMINOLOGY** Definitions and terms are in accordance with definitions in ANSI/NFRC 100 and Terminologies in ASTM C 168, ASTM E 631 and ASTM E 772 from which the following have been selected and modified to apply to fenestration systems.

**Air leakage:** the volume of air flowing per unit time through a test specimen because of air pressure or temperature difference on both sides of the specimen.

**Fenestration system:** a fenestration is a glazed aperture in a building for the controlled admission of solar radiant heat and light. A fenestration system is a system of usually planar (but sometimes curved) transparent or translucent glazings, frames holding the glazing, mullions, muntin bars, dividers and other attachments and/or shading devices that form the fenestration system. The glazing can include glass or plastic sheets that are patterned, corrugated or otherwise distorted, so long as some visible light can pass through them. The fenestration system is often referred to as the test specimen in this document.

**Standard barometric pressure:** standard barometric pressure is 101.325 kPa (29.92 in Hg).

**Surface heat transfer coefficient,  $h$**  (sometimes called surface conductance or film coefficient): the time rate of heat flow from a unit area of a surface to its surroundings, induced by a unit temperature difference between the surface and the environment.

**Time constant:** the time for energy (density  $\times$  flow rate  $\times$  specific heat at constant pressure  $\times$  temperature difference) carried in the fluid leaving the test chamber to attain  $1/e$  (63.2%) of its steady-state change following an instantaneous step change in the irradiance incident upon the test aperture.

**Thermal Opening Area:** The area of the TDD/HTDD product at the interior-most plane of the building's thermal envelope.

**Thermal transmittance,  $U_s$**  (sometimes called the overall coefficient of heat transfer or air-to-air U-factor): the heat transfer in unit time

through unit area of a test specimen and its boundary air films, induced by unit temperature difference between the environments on each side. The U-factor is the inverse of the overall R-value.

### 3.2 Descriptions of Terms Specific to this Standard:

**Air mass:** the ratio of the mass (optical thickness) of atmosphere in the actual observer-sun path to the mass that would exist if the observer was at sea level, at standard barometric pressure and if the sun was directly overhead (at the zenith).

**Angle of incidence:** the angle between the solar beam and the normal (perpendicular) to the plane on which it is incident. (The plane of incidence may be the aperture plane, the glazing plane or any other plane of interest)

**Artificial Sunlight:** a light source having similar a spectral distribution to the sun. See Solar Simulator

**Calibration Transfer Standard (CTS):** an insulation board that is faced with glazing, instrumented with temperature sensors between the glazing and the insulation board core, which is used to calibrate the surface heat transfer coefficients and the surround panel (See Annex A1 in ASTM C 1199 for design guidelines for Calibration Transfer Standards). The thermal conductance of the insulation board core is known by measurement using ASTM C 177 or ASTM C 518.

**Control boundary:** the system boundary is one of three elements, which comprise all thermodynamic systems. It is an imaginary surface, which divides the system volume and the surroundings. The calorimeter system boundary consists of an imaginary surface defined by the exterior surfaces of the surround panel and calorimeter walls.

**Solar irradiance:** the quantity of radiant flux incident upon a surface from all directions and over all wavelengths per unit area.

**Solar irradiance, average:** the time integral of solar irradiance incident on a unit surface area over a specified time period divided by the duration of that time period.

**Solar irradiance, global:** the solar irradiance incident upon an upward-facing horizontal surface directly from the solid angle of the sun's disk and scattered or diffusely reflected in traversing the atmosphere. This includes direct and diffuse solar radiation

**Profile angle:** the angular difference between a horizontal plane and a plane tilted about a horizontal axis in the plane of the fenestration until it includes the sun.

**Pyranometer:** a radiometer used to measure the total solar radiant energy incident upon a surface per unit time per unit area. This energy

may include the direct radiant energy, the diffuse sky radiant energy and the reflected radiant energy from the foreground.

**Steady-state conditions:** state of the solar calorimeter test when the heat flow rate removed by the fluid flowing through the absorber plate and the temperatures within the solar calorimeter and on the test specimen are constant. The exit fluid temperature changes are small and due to only the usual change in irradiance that occurs with time for clear sky conditions.

**Solar-Air Heat Transfer Coefficient Meter:** an insulated flat black plate, which is in the same plane and solar exposure as the test specimen that is used to measure the instantaneous exterior surface heat transfer coefficient (See Annex A).

**Solar calorimeter:** an insulated enclosure designed to permit the continuous introduction and extraction of a measured flow of fluid mass and equipped with an empty aperture into which a fenestration system is inserted for testing. During a test, solar radiation (or simulated solar radiation) is made to be incident upon the fenestration at a known rate. An energy balance performed over the calorimeter, which incorporates heat extracted by the fluid, wall losses and power input to internal mechanisms, is indicative of the net energy gain (solar heat gain minus thermal losses) through the fenestration.

**Solar heat gain (SHG):** the amount solar incident energy transmitted through a system in question. Included are both directly transmitted solar radiation as well as solar energy absorbed by the fenestration system and re-transmitted into the inside space.

**Solar heat gain coefficient (SHGC):** the ratio of solar heat gain through the fenestration system per unit area to solar radiation incident on the system per unit area, for a given angle of incidence and for given environmental conditions (indoor temperature, outdoor temperature, wind speed, direction and solar radiation). The SHGC can be expressed as follows:

$$SHGC = \tau_s + N_i \alpha_s \quad \text{Equation 3-1}$$

Where

- $SHGC$  = Solar Heat Gain Coefficient
- $\tau_s$  = solar transmittance of fenestration system
- $N_i$  = inward-flowing fraction of absorbed radiation
- $\alpha_s$  = solar absorptance of a single-pane fenestration system

**Solar radiation:** electromagnetic radiation covering the spectral range from 300 to 4000 nm coming from either natural direct beam solar

radiation or from an artificial radiation source having a similar spectral distribution.

**Solar Simulator:** device that provides a controllable illumination source approximating natural sunlight for the purpose of indoor testing under laboratory conditions.

**Surround panel** (sometimes called the mask, mask wall or homogeneous wall): a uniform structure of homogeneous, low conductivity material that both supports the test specimen and provides a uniform, reproducible energy flux pattern at the edges of the solar calorimeter perimeter. (See Section 6.2.3 for a description of a surround panel.)

**Test specimen:** (also called the specimen) the fenestration system or product being tested.

### 3.3 Symbols

The symbols, terms and units used in this test method are as follows:

- $A_s$  *projected area of test specimen, (same as open area in surround panel),  $m^2$  ( $ft^2$ )*
- $A_{sp}$  *projected area of surround panel, (does not include open area in surround panel),  $m^2$  ( $ft^2$ )*
- $\alpha_s$  *solar absorptance of surface*
- $C_g$  *thermal conductance of glass or acceptable transparent plastic facing on Calibration Transfer Standard,  $W/m^2K$  ( $Btu/h \cdot ft^2 \cdot ^\circ F$ )*
- $C_{sp}$  *thermal conductance of surround panel (surface to surface),  $W/m^2K$  ( $Btu/h \cdot ft^2 \cdot ^\circ F$ ), determined by means of ASTM C 177 and ASTM C 1045, ASTM C 518 and ASTM C 1045 or ASTM C 1114 and ASTM C 1045*
- $C_{ts}$  *thermal conductance of Calibration Transfer Standard,  $W/m^2 \cdot K$  ( $Btu/h \cdot ft^2 \cdot ^\circ F$ ), determined by means of ASTM C 177 and ASTM C 1045, ASTM C 518 and ASTM C 1045 or ASTM C 1114 and ASTM C 1045*
- $\varepsilon$  *emittance of surface*
- $E_s$  *incident solar irradiance,  $W/m^2$  ( $Btu/h \cdot ft^2$ )*
- $F_{1b}$  *interior calorimeter radiative view factor*
- $h_{h\ sun}$  *exterior surface heat transfer coefficient, as measured on the Solar-Air Heat Transfer Coefficient Meter,  $W/m^2K$*

	$(\text{Btu/h}\cdot\text{ft}^2\cdot^{\circ}\text{F})$
$h_{\text{STh}}$	<i>standardized surface heat transfer coefficient, calorimeter side, <math>\text{W/m}^2\text{K}</math> (<math>\text{Btu/h}\cdot\text{ft}^2\cdot^{\circ}\text{F}</math>)</i>
$h_{\text{STc}}$	<i>standardized surface heat transfer coefficient, weather side, <math>\text{W/m}^2\text{K}</math> (<math>\text{Btu/h}\cdot\text{ft}^2\cdot^{\circ}\text{F}</math>)</i>
$h_{\text{h}}$	<i>surface heat transfer coefficient, calorimeter side, <math>\text{W/m}^2\text{K}</math> (<math>\text{Btu/h}\cdot\text{ft}^2\cdot^{\circ}\text{F}</math>)</i>
$h_{\text{c}}$	<i>surface heat transfer coefficient, weather side, <math>\text{W/m}^2\text{K}</math> (<math>\text{Btu/h}\cdot\text{ft}^2\cdot^{\circ}\text{F}</math>)</i>
$\theta$	<i>incident angle, degrees</i>
$\theta_{\text{E}}$	<i>average incident angle, degrees</i>
$L$	<i>length of heat flow path, m (ft)</i>
$m$	<i>mass flow rate, kg/s (lb/h)</i>
$N_{\text{i}}$	<i>inward flowing fraction</i>
$\Psi$	<i>profile angle, degrees</i>
$\Psi_{\text{E}}$	<i>average profile angle, degrees</i>
$Q$	<i>time rate of heat flow through the total surround panel/test specimen system, <math>\text{W}</math> (<math>\text{Btu/h}</math>)</i>
$Q_{\text{aux}}$	<i>thermal transmittance of test specimen (air to air under test conditions), <math>\text{W/m}^2\text{K}</math> (<math>\text{Btu/h}\cdot\text{ft}^2\cdot^{\circ}\text{F}</math>)</i>
$Q_{\text{c}}$	<i>time rate of convective heat flow from test specimen surface, <math>\text{W}</math> (<math>\text{Btu/h}</math>)</i>
$Q_{\text{env}}$	<i>time rate of heat flow through the calorimeter walls, surround panel and energy input by the fans and pumps, <math>\text{W}</math> (<math>\text{Btu/h}</math>)</i>
$Q_{\text{fl}}$	<i>time rate of flanking loss heat flow around surround panel, <math>\text{W}</math> (<math>\text{Btu/h}</math>)</i>
$Q_{\text{fluid}}$	<i>time rate of heat flow from the absorber plate into the fluid passing through it, <math>\text{W}</math> (<math>\text{Btu/h}</math>)</i>
$Q_{\text{net}}$	<i>time rate of heat flow into solar calorimeter, <math>\text{W}</math> (<math>\text{Btu/h}</math>)</i>
$Q_{\text{r}}$	<i>time rate of net radiative heat flow from test specimen surface to the surroundings, <math>\text{W}</math> (<math>\text{Btu/h}</math>)</i>
$Q_{\text{s}}$	<i>time rate of heat flow through the test specimen, <math>\text{W}</math> (<math>\text{Btu/h}</math>)</i>
$Q_{\text{sp}}$	<i>time rate of heat flow through the surround panel as determined from measured conductance <math>C_{\text{ts}}</math> and area weighted surround panel surface temperatures, <math>\text{W}</math> (<math>\text{Btu/h}</math>)</i>
$Q_{\text{U-factor}}$	<i>time rate of heat flow through the test specimen due to a</i>

- temperature difference across the unit, W (Btu/h)*
- $Q_{\text{walls}}$  *time rate of heat flow through the solar calorimeter walls due to a temperature difference between the inside and outside, W (Btu/h)*
- $q$  *heat flux (time rate of heat flow through unit area), W/m<sup>2</sup> (Btu/h·ft<sup>2</sup>)*
- $q_s$  *heat flux through the test specimen, W/m<sup>2</sup> (Btu/h·ft<sup>2</sup>)*
- $q_{r1}$  *net radiative heat flux to the calorimeter side of the test specimen, W/m<sup>2</sup> (Btu/h·ft<sup>2</sup>)*
- $q_{r2}$  *net radiative heat flux from the weather side of the test specimen, W/m<sup>2</sup> (Btu/h·ft<sup>2</sup>)*
- $q_{c1}$  *convective heat flux to the calorimeter side of the test specimen, W/m<sup>2</sup> (Btu/h·ft<sup>2</sup>)*
- $q_{c2}$  *convective heat flux from the weather side of the test specimen, W/m<sup>2</sup> (Btu/h·ft<sup>2</sup>)*
- $\rho$  *reflectance of surface*
- $R_s$  *overall thermal resistance of test specimen (air to air under test conditions), m<sup>2</sup>K/W (h·ft<sup>2</sup>·°F/Btu)*
- SC *Shading Coefficient*
- SHGC *Solar Heat Gain Coefficient*
- $T_s$  *solar transmittance of fenestration system*
- $t_{b1}$  *equivalent radiative baffle surface temperature, calorimeter side, K or °C (R or °F)*
- $t_h$  *average temperature of calorimeter side air, K or °C (R or °F)*
- $t_c$  *average temperature of weather side air, K or °C (R or °F)*
- $t_{sp1}$  *average temperature of calorimeter side of surround panel, K or °C (R or °F)*
- $t_{sp2}$  *average temperature of weather side of surround panel, K or °C (R or °F)*
- $t_1$  *average temperature of test specimen calorimeter side surface, K or °C (R or °F)*
- $t_2$  *average temperature of test specimen weather side surface, K or °C (R or °F)*
- $t_1'$  *average temperature of room side glass/core interface of*

- calibration transfer standard, K or °C (R or °F)*
- $t_2$  *average temperature of weather side glass/core interface of calibration transfer standard, K or °C (R or °F)*
- $U_M$  *modified thermal transmittance of test specimen [in the absence of the exterior surface heat transfer coefficient],  $W/m^2K$  (Btu/h·ft<sup>2</sup>·°F)*
- $U_S$  *thermal transmittance of test specimen (air to air under test conditions),  $W/m^2K$  (Btu/h·ft<sup>2</sup>·°F)*
- $U_{ST}$  *Standardized thermal transmittance of test specimen,  $W/m^2K$  (Btu/h·ft<sup>2</sup>·°F)*

#### 4. SIGNIFICANCE AND USE

- A. This test method details the calibration and testing procedures and necessary instrumentation required to measure the Solar Heat Gain Coefficient of fenestration systems installed in a solar calorimeter.
- B. Since the irradiance, spectral distribution, incident angle of solar radiation, temperatures and the surface heat transfer coefficients all affect the SHGC of many fenestration products, use of standardized conditions will assist in comparing results of tests performed at dissimilar test sites. Standardized test conditions for rating the SHGC of fenestration systems are specified in Section 7, and the standardized test conditions for testing Tubular Daylighting Devices are described in Annex G.
- C. Fenestration systems in buildings may accept solar radiation from the direct sun, the diffuse sky and radiation reflected from the ground and surrounding objects. The solar radiation incident on an (indoor or outdoor) solar calorimeter during a test will be different from what a fenestration system installed in a building might experience.
- i. Solar calorimeters that are located outdoors are often tilted to non-vertical orientations in an effort to minimize the variation of incident angle during the test period. This is important when testing the SHGC of fenestration systems, which produce different SHGCs at different incident angles (i.e., venetian blinds). When a solar calorimeter is tilted, the surface heat transfer coefficients of the test specimen differ from those experienced at a vertical orientation and the test specimen's view of the sky and ground is different. The characteristics of the

diffuse radiation from the sky can be very different from those of the diffuse radiation from the ground, depending on the solar angle, sky conditions and the specific foreground within the view of the solar calorimeter. By tilting the solar calorimeter, the test specimen's view of the sky increases and the view of the ground decreases, which may significantly change the irradiance, especially its spectral and angular distribution incident on the test specimen.

Note: Preliminary research has shown that the results from some solar calorimeters tilted beyond 60° from vertical should not be used to represent vertical test results. Unless the solar calorimeter has been calibrated and can demonstrate accurate results with a specimen tilted beyond 60° from vertical, tests on products that are intended to be installed in a vertical orientation shall not be performed with a tilt angle greater than 60°.

- ii. The spectral distribution of both the direct and diffuse solar irradiation at the earth's surface can vary with location, season and time of day. Although these variations are typically not significant when testing the SHG of clear or lightly tinted and uncoated glazing systems, they can influence the measured results if the test specimen has complex spectral or angular optical characteristics. For these reasons, the SHG results of these types of products measured at one outdoor laboratory may vary from the results measured at another outdoor laboratory in a different location. Also, the SHG results from the same laboratory on the same test specimen may vary based on the time of year, solar altitude angle and/or time of day it was tested. The magnitudes of the errors that can be introduced from these variations are not large but can be significant, depending upon the degree of spectral and/or angular selectivity inherent in the optical properties of the test specimens used. Further research is required to assess these errors and find ways to reduce them. If the spectral characteristics of the test specimen are known, as well as that of the incident solar radiation (either by measurement or calculation) it should be possible to determine a correction factor to minimize these errors, but this procedure has been neither identified nor standardized.
- iii. Solar calorimeters that are located indoors may use an electric lamp or a series of lamps, filters and reflectors,

(solar simulators) to approximate the characteristics of direct beam solar radiation from the sun, as transmitted through the Earth's atmosphere. Although the spectral distribution of the radiation from an artificial light source must meet the specifications outlined in Section 7.2.2.2, there will always be some differences between the spectral distribution of the radiation emitted by an artificial source and the radiation from the sun transmitted through the Earth's atmosphere. These differences can produce different results for the same test specimen when measured with different solar simulators and differences in measurements with a solar simulator and with real solar radiation.

- (a) In addition, solar calorimeters that are located indoors are usually not exposed to real or simulated diffuse irradiation from the sky and the ground. As a result, all of the incident solar radiation is contained in the direct beam. See Section 7.2.2.2 for methods to minimize the differences between artificial light sources and the actual solar radiation at the Earth's surface and Section 9.1 for the minimum reporting requirements for indoor solar calorimeters.
- iv. Because of the possible spectral selectivity effects discussed in Sections 4.c.ii and 4.c.iii, differences have been noted between calorimeter measurements of a test specimen and calculations of the solar heat gain coefficient of that specimen made with widely used, two-dimensional, fenestration thermal performance rating software based on ISO 9050 and ISO 15099. These programs use an ASTM standard air mass 1.5 solar spectral distribution weighting function in its calculation of the SHGC. If the specimen is tested with a calorimeter either outdoors or indoors using real or simulated solar radiation having a spectral distribution significantly different from the ASTM standard, significant differences in measured and calculated SHGC values can result, depending upon the spectral selectivity of the test specimen. It has been found that the use of a more representative solar spectrum weighting function in the fenestration thermal performance rating software calculation can reduce the differences between calculation and measurement. Future versions of these fenestration thermal performance rating programs are

expected to contain an option for changing the source spectrum to a more realistic one.

- D. It should be noted that the interior surface heat transfer coefficient on the calorimeter side,  $h_h$ , as determined prior to testing a fenestration product by using an appropriately sized Calibration Transfer Standard (CTS), may differ from the interior surface heat transfer coefficient that exists inside of the solar calorimeter during a SHGC test. Fenestration systems usually have frame and sash surfaces, which introduce two- and three-dimensional convective heat transfer that results in variable surface heat transfer coefficients which differ from the CTS values. In addition, solar calorimeters that are located outside are often tilted to non-vertical orientations to keep the incident angle constant and the surface coefficients will change with tilt angle. As a result of all these factors, the test specimen surface heat transfer coefficients will not be equal to those obtained with the non-framed, approximately two-dimensional Calibration Transfer Standard used as a reference under the same conditions. It should be recognized that this assumption of equality will not be accurate for all fenestration products, especially for high thermal transmittance products in which the surface heat transfer coefficients are a major portion of the overall thermal transmittance and also for fenestration products with significant projection (e.g., skylights, roof windows, garden windows) for which the surface heat transfer coefficients are quite different from the CTS values.
- E. The SHGC of a test specimen is affected by its three-dimensional shape and also by its size (since the glazing does not scale along with the frame). Care must be exercised when extrapolating to product sizes smaller or larger than the test specimen. Therefore, it is recommended that fenestration systems be tested at the recommended sizes specified in ASTM E 1423 or ANSI/NFRC 100.

**Note:** This test method does not include separate procedures to determine the heat flows due to either air movement through the specimen or nighttime U-factor effects. As a consequence, the SHGC results obtained do not reflect the overall performance, which may be found in field installations due to temperature differences, wind, shading, air leakage effects and the thermal bridge effects specific to the design and construction of the fenestration system opening. Since there are a wide variety of fenestration system openings in North American residential, commercial and industrial buildings, it is not feasible to select a “typical” surround panel construction in which to mount the fenestration test system. The selection of a relatively high

thermal resistance surround panel, places the focus of the test on the thermal performance of the fenestration system alone. Therefore, it should be recognized that the thermal transmittance results obtained from this test method, for ideal laboratory conditions in a highly insulating surround panel, should only be used for fenestration product comparisons or as input to thermal performance analyses which also include solar, air leakage and thermal bridge effects due to the surrounding building structure. To determine air leakage effects for windows and doors, refer to ASTM E 283, ASTM E 783 or ASTM E 1424. For thermal transmittance, refer to ASTM C 1199.

---

## 5. CALIBRATION Overall Calibration Requirements

Calibration of the calorimeter is required on each separate system level. Before testing of actual fenestration can occur, the instrumentation and systems of the calorimeter shall be calibrated, and the operating characteristics of the calorimeter shall be determined.

### Required Calibration - Primary Measurement Equipment

All calibrations shall be performed either in-house or by an ISO 17025 accredited calibration laboratory. If in-house calibrations are performed, the calibration equipment shall be calibrated annually by an ISO 17025 accredited calibration laboratory.

**Table 5-1 – Calibrations Required**

Calibrations Required	Frequency
Pyranometer	Annual
Fluid Flowmeter	Annual
Fluid Heat Extraction System	Annual
Metering Box Wall Transducer and Surround Panel Flanking Loss Characterization	Once and done but verified annually
Reference Glazing	Annual system verification (see Section 4.5.2)
Thermocouples	Annual
Data Acquisition System's	Annual

Calibrations Required	Frequency
I/O Module	
Interior Wind Velocity Sensors	Annual
Exterior Wind Velocity Sensors	None -- Monitoring device only. Exterior film coefficient calculated using the device described in Annex A. Alternative methods of monitoring velocity shall be allowed if properly documented by the laboratory.
Surround Panel/Characterization Panel Apparent Thermal Conductance Characterization	Once and done.
CTS Core Apparent Thermal Conductance Characterization	Once and done.
CTS Calibration (Surface Coefficients)	Once and done. Recalibration is required if modifications are made to the calorimeter.

## 5.2 Instrument Calibration

Calibration of individual instruments shall be performed prior to system calibration. While periodic calibration of some of these devices is prudent (e.g., pyranometers and flowmeters), recalibration of all devices may be impossible (e.g., surface temperature difference thermopiles imbedded in the calorimeter walls). Care should be taken to accurately characterize and document such instruments and sensors during the construction of the calorimeter. The method and frequency of the calibration of some of the primary instruments used in solar calorimeter testing are discussed below.

### 5.2.1 Pyranometer Calibration

Of all the instrumentation, maintaining the accuracy of the pyranometer is the most critical to the measurement of solar heat gain. Error in the measurement of the incident solar irradiation is directly proportional to the error in measuring the solar heat gain coefficient. Therefore, the pyranometer shall be calibrated using ASTM E 824 before use and at a minimum frequency of once a year thereafter. ASTM E 824 calibrations shall be performed at normal incidence (Type C) and at a tilt

angle of  $40^{\circ} \pm 20^{\circ}$  from horizontal. Certain types of pyranometers, (e.g., black and white thermopile sensors) have been shown to have a more significant variation in their calibration coefficient during their initial years of use and therefore may require more frequent calibration over this period. A periodic comparison of the results from the solar calorimeter against the reference glazing test specimen specified in Section 5.5.2.1 and comparison of the primary pyranometer against other pyranometers, which are kept in a dark, thermally stable environment most of the time, can help identify variations in the pyranometer calibration coefficient over time.

### **5.2.2 Fluid Temperature Difference**

The fluid temperature difference sensors shall be calibrated annually. Depending on the type of temperature sensors used, calibration of a multi-junction thermopile or RTD sensor may be required at more frequent intervals as identified by the instrument manufactures' specifications.

### **5.2.3 Fluid Flow Rate**

The instrumentation used to measure the fluid flow rate shall be calibrated at least once a year. As a secondary check between calibrations, the flow rate can be easily verified using a stopwatch and a graduated or weighed bucket.

## **5.3 System Characterization**

### **5.3.1 Temperature Measurements**

The following temperature measurements are required during system calibration tests.

#### **5.3.1.1 Interior Surface Temperatures**

The temperatures of all interior solar calorimeter surfaces (baffles, absorber plate, etc.) exchanging heat with or in view of the calibration panel, surround panel or test specimen shall be measured. In addition, the surface temperatures on both sides of the calibration or surround panel shall be measured. All surface temperature measurements shall be made using the temperature sensor attachment techniques and area weighing criteria specified in Section 6.10 of ASTM C 1363. Surface temperatures shall be measured to  $\pm 1.0^{\circ}\text{C}$  ( $\pm 1.8^{\circ}\text{F}$ ).

#### **5.3.1.2 Surface Temperature Difference**

The temperature difference across the solar calorimeter walls (control boundary) shall be measured using multi-junction thermopiles or equivalent instrumentation (see Section 6.2.2.5). All surface temperature measurements shall be made using the temperature sensor attachment techniques and area weighing criteria specified in Section 6.5.4 of ASTM C 1363. See Annex A2 for more information on how to determine the solar calorimeter wall loss. The temperature sensors shall be capable of measuring a temperature difference to sufficient accuracy to allow wall losses to be determined within  $\pm 1.0 \text{ W}$  ( $\pm 3.4 \text{ Btu/h}$ ).

#### **5.3.1.3 Air Temperatures**

The average interior air temperature of the solar calorimeter shall be a defined measurement on a plane parallel with the surface temperature sensors on the surround panel. As a minimum requirement, this shall be the mean of measurements at three locations equidistant from the vertical centerline of the surround panel. All air temperatures shall be measured in accordance with Section 6.10 of ASTM C 1363. Special care needs to be taken with air temperature sensors located in direct sunlight as they need to be shielded from effects of solar irradiation. A thin-walled aluminum shield painted white on the outside and inside surfaces and typically measuring up to 50 mm (2 in) in diameter by 100 mm (4 in) long placed around the bead and leading wire of the thermocouple has been shown to be adequate for this purpose, although some have successfully used shields that are smaller in dimension or made of specularly reflecting aluminum. In addition the ambient air temperature near the solar calorimeter shall be measured in at least one location at a distance not to exceed 2 meters (6 feet) from the solar calorimeter. The ambient air temperature sensor shall be placed at a location that is shaded from direct solar irradiation. Air temperatures shall be measured to  $\pm 1.0^\circ\text{C}$  ( $\pm 1.8^\circ\text{F}$ ).

#### **5.3.1.4 Fluid Temperature Difference**

The temperature difference between the fluid flowing into the solar calorimeter and the fluid exiting the solar calorimeter shall be measured by a multi junction thermopile or equivalent device. The temperatures of the inlet and outlet fluid shall also be measured at a location

central in the flow. The temperature sensors shall be capable of measuring temperature differences within  $\pm 0.05^{\circ}\text{C}$  ( $\pm 0.09^{\circ}\text{F}$ ).

Note: The temperature sensor requirements given in Section 5.3.1 and Subsections 5.3.1.1 through 5.3.1.4 are general requirements. Section 7.2.5 on test specimen temperature measurements may suggest additional temperature sensors, dependent on the test specimen type. More temperature sensors shall be used if they provide a more representative area-weighted average temperature (air and surface).

#### **5.3.1.5 Fluid Flow Rate Measurements**

The flow rate of the fluid flowing through the solar calorimeter heat exchanger shall be measured by instrumentation or methods accurate to  $\pm 1.0\%$ . Alternatively, the mass of fluid through the heat exchanger over a measured time interval and the time interval shall be measured by instrumentation or methods accurate to  $\pm 1.0\%$ .

#### **5.3.2 Miscellaneous Power Input**

Power provided to the calorimeter to operate internal pumps, fans or other electrical equipment shall be measured. Power levels shall be determined to within  $\pm 1\text{ W}$  ( $\pm 3.4\text{ Btu/h}$ ) or  $\pm 1.0\%$  of reading, whichever is most accurate.

#### **5.3.3 Irradiance Measurements**

The level of solar irradiance shall be determined. Irradiance measuring devices shall be calibrated to  $\pm 2.0\%$  accuracy as specified in Section 5.2.1. See Section 6.3.1 for a more detailed description of the minimum requirements of pyranometers or similar solar irradiation measuring devices.

### **5.4 System Characterization Tests**

The following four calibration test procedures shall be followed to characterize the performance of the solar calorimeter cell. Two of the calibration tests require that a calibration panel or continuous surround panel (the test specimen aperture is filled with the same material as the rest of the surround panel) be tested under different test conditions. Three calibration tests are performed under “night-time” conditions,

without the influence of solar irradiation and the remaining calibration test is performed with actual test specimens under full solar irradiation.

#### **5.4.1 General System Calibration Requirements**

The following equipment and set-up are required for system calibration tests.

##### **5.4.1.1 Calibration Panel or Surround Panel**

The solar calorimeter wall calibration test and the surround panel flanking loss tests require that a continuous surround panel or calibration panel (one without the test specimen aperture cut in it) be installed in the solar calorimeter with temperature sensors attached to both sides as specified in Annex F. A surround panel (one with the test specimen aperture cut in it) is required for the time constant calibration tests and the reference specimen tests. See Annex F for more detailed information on how to construct and instrument a surround panel and calibration panel.

##### **5.4.1.2 Air Leakage**

All potential air leakage sites on the calibration and surround panel and at the interface between the panel and the solar calorimeter, shall be sealed with tape and/or caulking as close to the primary seal as possible to minimize or eliminate air leakage between the interior of the solar calorimeter and the outside. The surface emittance and solar absorptance of the tape or caulk shall be similar to ( $\pm 0.1$ ) the emittance and solar absorptance of the surround panel surface. If the surround panel is assembled from different pieces of the same material, the joints between surround panel pieces shall be sealed on both sides of the surround panel. In no case shall the tape or caulk cover more than 25 mm (1 in) on each side of the surround panel edge.

Note: As an additional precaution to minimize the potential for leakage of air through and around the sealed test specimen, means may be provided to measure and equalize the pressure difference across the test specimen. See Section 7.1.3 of ASTM E 1423 for additional information on how to equalize the pressure difference across the test specimen.

##### **5.4.1.3 Heat Input Measurement and Instrumentation**

To perform the solar calorimeter wall calibration tests as specified in Annex B, heat lamps or similar devices are placed inside of the calorimeter to produce a power input within the solar calorimeter. The heat source shall be centered in the interior space of the solar calorimeter and be situated as to fully irradiate the solar absorber plate, without exchanging heat by radiation with the surround panel. The total energy input to the inside of the solar calorimeter shall be measured and recorded by instrumentation accurate to  $\pm 1.0\%$ .

#### **5.4.2 Calibration of Solar Calorimeter Wall Heat Flux**

The initial calibration test requires that the calorimeter is able to accurately determine the power input to the calorimeter when little to no inside/outside temperature gradient exists. This calibration is actually a series of tests that are used to define the relationship between heat transfer through the walls of the solar calorimeter and the output from the heat flux transducers or thermopile used to measure the temperature difference or heat flux across the calorimeter walls. Annex B describes the theory and methodology used to perform the solar calorimeter wall heat flux calibration tests, which are required before additional calibration and testing is performed.

#### **5.4.3 Surround Panel Flanking Loss Calibration**

The surround panel flanking loss calibration test method is described in detail in Annex C. The surround panel flanking loss shall be determined using the procedure specified in Annex C for each thickness and construction of surround panel. For this calibration test, the temperature of the outdoor face of a calibration panel, which is constructed of the same material as the surround panel, is maintained at a higher temperature than the interior air temperature within the solar calorimeter. This test is performed under full sunlight with a calibration panel installed in the calorimeter. See Annex C for a complete description on how to determine the surround panel flanking loss of each surround panel.

#### **5.4.4 Time Constant Determination**

To establish when steady-state conditions occur it is necessary to determine the time constant of the solar calorimeter cell, surround panel and specimen. Annex D specifies the methodology used to measure the time constant of the solar calorimeter apparatus and a means to estimate the time

constant of the test specimen. The minimum time constant that can be used during actual tests shall not be less than ten minutes.

## **5.5 System Verification Tests**

After the initial calibration tests have been performed, tests of well-characterized test specimens shall be conducted to confirm the expected performance of the calorimeter cell. The previous calibration tests require that calibration panels and glazing systems be tested under different test conditions. These additional tests shall be conducted using a Calibration Transfer Standard (CTS) and reference glazing test specimens, which shall both be installed in an aperture cut in the surround panel.

### **5.5.1 Internal Surface Heat Transfer Coefficient**

The test facility surface heat transfer coefficient shall be calibrated using a heat flux transducer Calibration Transfer Standard constructed as described in Annex A1 of Test Method C 1199. The Calibration Transfer Standard has a core material of known characteristics traceable to primary standards such as the guarded hot plate of a national standard laboratory. The projected area of the Calibration Transfer Standard shall cover the same range as the test specimen model size and tolerance as specified in ANSI/NFRC 100. If the solar calorimeter is to be used at non-vertical orientations, a minimum of three CTS tests shall be performed covering the range of tilt angles encountered during testing. See Annex A5 for the required standard temperatures, surface heat transfer coefficients and tolerances. Solar calorimeters using a Solar-Air Heat Transfer Coefficient Meter as described in Annex A shall not be required to satisfy the exterior surface heat transfer coefficient tolerance. See Annex E for a detailed description of how to perform the Calibration Transfer Standard tests.

### **5.5.2 Real System Tests**

These tests shall be conducted in full sun using the procedures outlined in Sections 7 and 8.

#### **5.5.2.1 General Description**

Data taken from a calorimeter shall be compared to at least one well-characterized test specimen, called a reference specimen or reference glazing. At a minimum, one of the reference glazings specified in the following section shall be tested. In this manner, the calorimeter

performance and calculation procedure can be verified. These tests should be performed after any equipment modification.

#### A. Reference Glazing Test

A reference glazing test specimen shall be constructed consisting of either single pane nominal 3 mm (1/8 in) glass or two panes of nominal 3 or 6 mm (1/8 in or 1/4 in) clear glass with a 12 mm (1/2 in) air gap. The 3 mm glass shall have a solar transmittance,  $\tau_s$ , of  $0.84 \pm 0.02$  and the 6 mm glass shall have a solar transmittance of  $0.78 \pm 0.02$  as determined by NFRC 300. The use of double glazing reduces the effects of exterior wind direction and speed and clear glass minimizes the effects of absorbed solar radiation in the test specimen, as well as spectral selectivity effects. If possible, the reference glazing test specimen should not have a frame and should be installed with glazing stops made from the same material as the surround panel. For structural reasons, wood may be used sparingly as a frame or as glazing stop material if it is painted white with a solar absorptance equal to or less than 0.2.

#### B. Reference Specimen Size

The reference specimen or glazing test specimen shall have sufficient size as to reduce uncertainty in the calculated SHGC. It shall not have less than 508 mm by 508 mm (20 in by 20 in) of visible area when installed in the surround panel.

#### C. Test Procedure

The test procedure shall be performed as described in Sections 7 and 8. The calibration test specimen shall be tested at as close to normal incidence as possible.

#### D. Expected Results

Clear single pane nominal 3 mm (1/8 in) thick glass has a SHGC of 0.87. For the double glazed calibration test specimen at normal incidence, the SHGC shall be 0.75 for the nominal 3 mm (1/8 in) thick glass and 0.70 for the nominal 6 mm (1/4 in) thick glass. SHGC results for other incident angles

can be found in Table 11 of ASHRAE Handbook of Fundamentals (Chapter 31). Tested results shall not vary from those expected by more than  $\pm 2\%$ .

SHGC for other fenestrations are well documented in Table 11 of ASHRAE Handbook of Fundamentals (Chapter 31) or can be calculated using approved ANSI/NFRC 200 software.

---

## 6.1 General Description of Measurement of Solar Heat Gain Coefficient

### 6. EXPERIMENTAL APPARATUS AND INSTRUMENTATION

- A. Solar calorimetry, by definition, is composed of power measurements (energy flux per unit time) made across a defined, closed control boundary, which includes a test specimen and the calorimeter enclosure (or calorimeter cell). The equipment for control of the interior thermal conditions supplies a metered power across the control boundary. All other power fluxes across the control boundary (with the exception of that across the test specimen) should be minimized and shall be measured and documented.
- B. The principal components used in the determination of SHGC by calorimetric methods (shown in Figure 6-1) may be generalized as:
- i. test specimen
  - ii. calorimeter cell and surround panel
  - iii. cell interior heat exchanger (or absorber)
  - iv. thermal loop and
  - v. external solar band radiation source.

Systems to measure the energy flux across sections of the control boundary are also an integral part of the apparatus.

**Figure 6-1 -- Typical components used in a calorimeter apparatus**

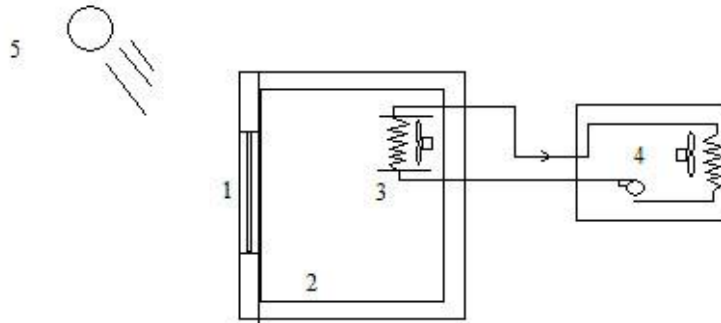

- C. The function of the calorimeter enclosure is to provide a controlled thermal environment (simulating the interior space within a building) and to collect incoming solar and long-wave radiation. The calorimeter usually consists of this insulated enclosure with an aperture in which the fenestration test specimens are mounted, and the heat removal measured. Design options used in the construction of calorimeter cells are described in Section 6.2.1.
- D. The air temperature within the calorimeter cell is typically controlled at a specified value through the combined use of a heat exchanger and circulation loop. These devices function to remove the incoming heat (slightly less or more in a servo loop) in order to maintain the cell conditions at the desired state. In the case of a liquid circulation loop, this may be accomplished by controlling fluid inlet temperature and flow rate. Low-power fans and auxiliary heaters may also be used to achieve more uniform temperature distributions and air flow within the test cell as long as their power inputs are measured.
- E. During calorimeter testing, either the sun or an artificial solar source irradiates the fenestration test specimen. Simulated solar irradiation is used to allow testing under stable and repeatable conditions without sunshine. The intensity, uniformity, direction and spectral characteristics of natural and artificial sunshine are important issues and are discussed in Section 7.3.2.1.
- F. Measurement instrumentation typically consists of temperature sensors, radiometers to measure total and direct normal solar radiation and long-wave thermal radiation, exterior film coefficient or wind speed transducers and envelope heat flux sensors. See Section 6.3 and Section 6.4 for the instrumentation requirements.

## 6.2 Description of Solar Calorimeter Cell

### 6.2.1 Design Options

There is a significant range in the design of calorimeters, primarily driven by the nature of the measurement intended. In general, these design options can be described by differing degrees of their capabilities.

#### **6.2.1.1 Tracking vs. Stationary**

Calorimeter test cells may be stationary or designed to track the sun as it sweeps across the sky during the day. This latter capability is intended to reduce variations in the intensity of the radiant energy due to the dependence of transmittance on incident angle.

#### **6.2.1.2 Guarded vs. Calibrated**

To account for energy losses or gains through the calorimeter walls, calorimeter designs generally follow one of two basic design approaches, which are referred to as "calibrated" or "guarded" designs. Calibrated designs rely on careful calibration (measurement) of the heat losses from the calorimeter and usually involve the use of heat-flux meters or temperature sensors embedded in sections of the calorimeter walls to determine losses. Guarded calorimeter cells attempt to eliminate the temperature difference across the calorimeter wall, thereby reducing heat losses to negligible levels. Techniques for guarding include the use of air guards that are separately air-conditioned spaces surrounding the test facility, fluid guards that are heated or cooled by a separate fluid flow loop or the use of actively controlled surface heaters attached to the exterior of the metering cell's walls.

#### **6.2.1.3 Dynamic vs. Steady-state**

Dynamic test methods allow the solar and environmental conditions to vary during the test period and as such shall account for the storage or release of energy within the calorimeter and test specimen. Steady-state methods require the calorimeter to come to thermal equilibrium before measurements are recorded and remain at that condition during data collection periods.

### **6.2.2 Solar Calorimeter Wall Construction, Absorber Plate and Instrumentation**

A cross section diagram of the walls of a calorimeter cell would show an interior absorber plate with an integral heat removal

system (liquid), insulation, temperature and heat flux instrumentation, optional guard or surface heaters and an exterior rigid shell. The absorber plate need not be part of the calorimeter wall. It can be separate or suspended to allow better convective heat transfer as well as heat absorption by radiation. The better contact the absorber has with the air in the calorimeter cell, the closer the air temperature will be to the heat exchanger surface, thus reducing thermal radiation effects. The absorber plate shall completely shade the calorimeter cell walls from solar radiation.

#### **6.2.2.1 Interior Air Temperature Instrumentation**

The average air temperature for the calorimeter interior shall be a defined measurement in a plane parallel with the surround panel and test specimen, at a distance of 75 mm (3 in) from the interior side of the surround panel.

- A. As a minimum requirement, this shall be the mean of measurements at three locations equidistant from the vertical centerline of the surround panel. All air temperatures shall be measured in accordance with Section 6.10 of Test Method C 1363. More air temperature sensors may be used. Any additional air temperature sensors shall be placed in an array of equally spaced locations in a plane parallel with the surround panel at a distance of 75 mm (3 in) from the interior side of the surround panel.
- B. The temperature sensors used shall be thermocouples (24 gage may be used, 30 gage or smaller are recommended) or appropriate size thermistors or RTD's (resistance temperature devices). Air temperatures shall be measured to  $\pm 1.0^{\circ}\text{C}$  ( $\pm 1.8^{\circ}\text{F}$ ).
- C. Air temperature sensors illuminated by direct or diffuse solar radiation shall be either shielded from solar radiation or shall have bright metallic surfaces, small sizes and mechanical and material properties designed to reduce measurement errors produced by radiative heat transfer. Temperature sensors exposed to heat exchanger surfaces within the calorimeter shall be similarly shielded from radiative heat transfer.

### 6.2.2.2 Interior Air Temperature Control

The interior air of the calorimeter shall be maintained at the temperature specified by the appropriate test practice (i.e., ANSI/NFRC 200).

- A. The air in the calorimeter shall be maintained at a spatially constant temperature. There shall be no more than 2.0°C (3.8°F) of temperature stratification per meter from top to bottom of the interior height of the solar calorimeter measured along the plane parallel to the surround panel and at a distance of 75 mm (3 in) from the surround panel surface.
- B. The spatially averaged air temperature in the calorimeter shall remain constant within  $\pm 2.0^{\circ}\text{C}$  ( $\pm 3.6^{\circ}\text{F}$ ) during the measurement period.
- C. The circulating air flow inside the calorimeter shall at no point exceed 0.3 m/s (0.7 mph). If variation of the flow rate adjacent (measured at a distance of 75 mm (3 in) from the inside surround panel surface) to the test specimen exceeds 0.1 m/s (0.2 mph) steps shall be taken to insure the uniformity of the air flow.

### 6.2.2.3 External Electrical Power Instrumentation

The total energy transmitted to the inside of the solar calorimeter by auxiliary heaters, fans or pumps shall be measured by instrumentation accurate to  $\pm 1.0\%$  of reading or  $\pm 1\text{ W}$  ( $\pm 3.4\text{ Btu/h}$ ), whichever is most accurate.

### 6.2.2.4 Interior Solar Calorimeter Walls and Absorber Plate

The interior walls of the calorimeter are heavily insulated or else guarded, to reduce heat transfer. The absorber plate is constructed from metal or other highly conductive material, which is in contact with a physical means for removing and measuring absorbed heat. Sometimes, the interior walls of the solar calorimeter themselves are designed to incorporate an interior absorber plate skin.

However, the absorber plate may also be freestanding within the calorimeter cell. The methodology used to suspend or support the absorber plate shall be designed and constructed as to minimize conducted heat transfer from the absorber plate into the calorimeter walls. The absorber plate shall completely shade the calorimeter cell walls from solar radiation. The heat extraction system is discussed in greater detail in Section 6.2.4.

- A. The absorptance of the interior surfaces of the calorimeter enclosure to (solar spectral bandwidth 300 nm to 3,500 nm) shall be not less than 0.94. The determination of its value shall be made by measurement, according to ASTM E 903 or NFRC 300.
- B. The emittance of the interior surfaces of the calorimeter enclosure shall be determined by measurement using ASTM C 1371, ASTM E 1585 or NFRC 301 and shall be not less than 0.90.
- C. Interior Surface Temperatures

The temperatures of all interior solar calorimeter surfaces (baffles, absorber plate, etc.) exchanging heat with or in view of the surround panel and test specimen shall be measured. All surface temperature measurements shall be made using the temperature sensor attachment techniques and area weighing criteria specified in Section 6.10 of ASTM C 1363. Surface temperatures shall be measured to  $\pm 1.0^{\circ}\text{C}$  ( $\pm 1.8^{\circ}\text{F}$ ).

#### **6.2.2.5 Insulated Walls of Solar Calorimeter**

The calorimeter walls are typically insulated with fiberglass or polystyrene foam (bead board). The insulation is placed between the absorber and the guard space, guard heaters or exterior shell of the solar calorimeter. The insulation shall be instrumented with temperature difference sensors to determine the heat flux through the walls during the test. These temperature difference sensors may be located across the wall of the solar calorimeter.

- A. The solar calorimeter wall insulation shall consist of a stable homogeneous insulation

material with a thermal conductance at 24°C (75.2°F) not in excess of 0.04 W/m<sup>2</sup>K (0.007 Btu/hr·ft<sup>2</sup>·°F) and having very low gas permeability.

- B. The inside-outside temperature difference across the chamber walls shall be measured using multiple junction thermopiles or equivalent instrumentation. The thermopile wires shall be embedded in the walls in such a way that there is no direct heat transfer path through the chamber walls. The temperature sensors shall be capable of measuring a temperature difference to sufficient accuracy to allow wall losses to be determined within  $\pm 1.0$  W ( $\pm 3.4$  Btu/h).

#### **6.2.2.6 Guarded Solar Calorimeter**

Guarded test cells effectively eliminate the temperature difference across the calorimeter cell wall, reducing heat losses to very low levels. Techniques for guarding include the use of fluid guards (see Figure 6-3), air guards, which are separately air-conditioned spaces surrounding the calorimeter cell or the use of actively controlled surface heaters attached to the exterior of the metering cell's walls (see Figure 6-2). This latter method is less bulky and therefore more practical for facilities that are designed to track the sun.

**Figure 6-2 -- Cross Section of Solar Calorimeter Wall Using Electric Heater Guard**

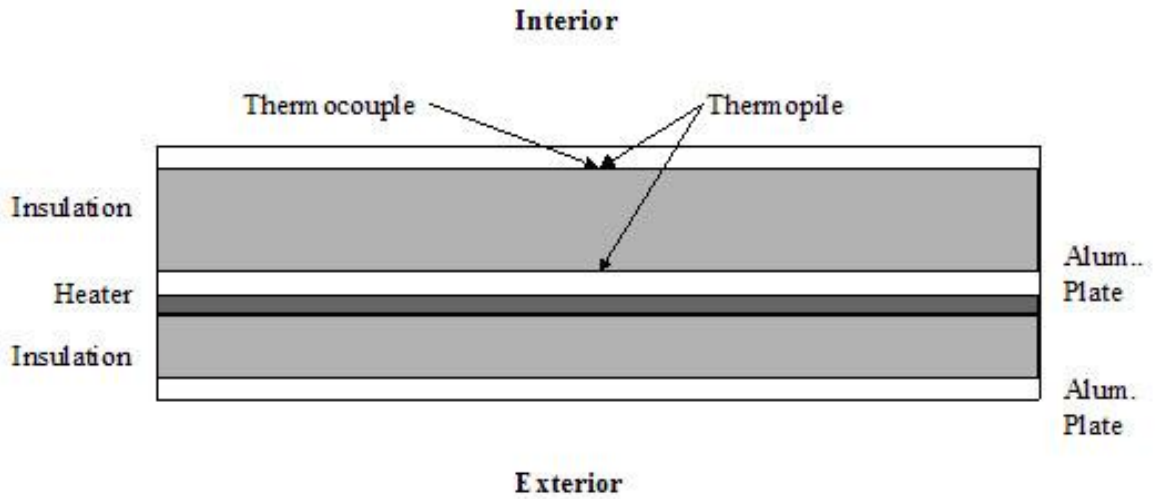

**Figure 6-3 -- Schematic of Actively Guarded Solar Calorimeter Using Fluid Heater Guard**

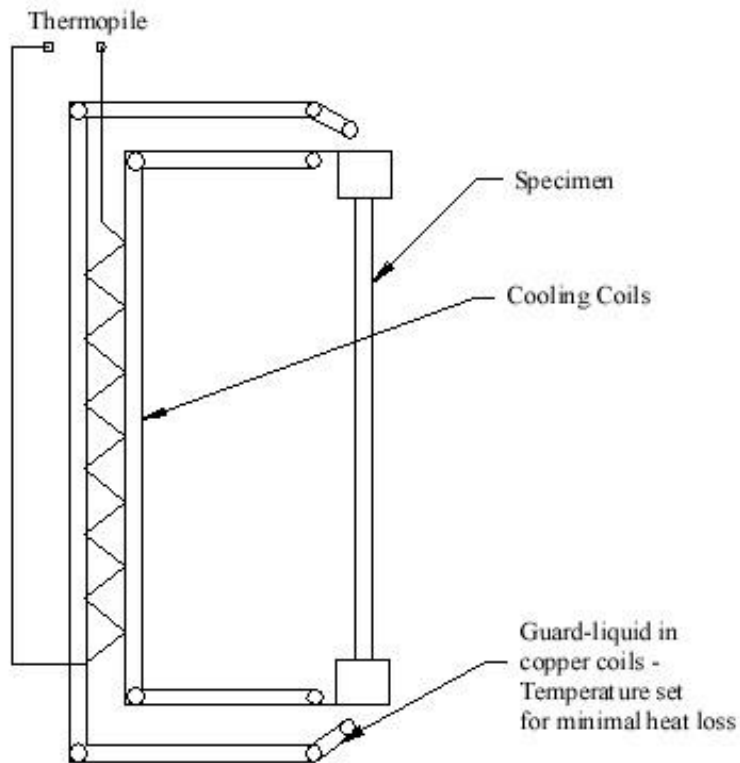

### 6.2.2.7 Exterior Shell of Solar Calorimeter

The solar calorimeter is covered with an exterior shell with a low solar absorptance, which protects the insulation and instrumentation from the influence of solar radiation and weather and often provides structural support to the solar calorimeter. Solar calorimeters located outdoors shall be painted white or other color with low solar absorptance, to reduce the influence of direct sunlight on the exterior wall during the test. An additional strategy to minimize the effects of direct solar irradiation on the sides of the solar calorimeter is to construct a 15 cm to 30 cm (6 in to 12 in) wide, white shade in the plane of the exterior face of the surround panel, which surrounds and protrudes from the perimeter of the solar calorimeter. This will only shade the walls of the calorimeter when it is facing the sun. This shade shall be designed so that it does not interfere with the operation of the Solar-Air Heat Transfer Coefficient Meter described in Annex A.

### 6.2.3 Surround Panel and Instrumentation

Test specimens are installed in surround panels that have been previously characterized using the calibration test procedures specified in Section 5. Surround panels are constructed and instrumented as specified in Annex F.

### 6.2.4 Heat Extraction System and Instrumentation

The walls of a calorimeter cell consist of an interior absorber plate with an integral heat removal system. Solar calorimeters receive significant energy from solar radiation transmitted through and absorbed by the test specimen. The interior air and walls of the calorimeter cell would quickly heat up if this heat was not removed. The absorbed solar energy is removed by transferring the heat, either by direct conduction from the solar absorption surface or by an air-to-fluid heat exchanger or both, to a suitable flowing heat transfer fluid. The heat gain (watts) by this fluid will be given by:

$$Q_{fluid} = \rho \cdot C_p \cdot f [T_e - T_i] \quad \text{Equation 6-1}$$

Where

- $T_i$  = inlet fluid temperature, °C (°F)
- $T_e$  = exit fluid temperatures, °C (°F)
- $f$  = fluid volumetric flow rate, m<sup>3</sup>/sec. (ft<sup>3</sup>/sec)
- $\rho$  = fluid density at constant pressure, kg/m<sup>3</sup> (lb/ft<sup>3</sup>)
- $C_p$  = specific heat at constant pressure, J/kg·°C (calorie/lb°F)

#### 6.2.4.1 Fluid Temperatures

The thermocouples used to measure the inlet and outlet temperatures and the temperature difference between them shall be placed in the middle of the fluid stream as close as practical to the insulated chamber wall.

##### A. Temperature Difference

The temperature difference measuring devices are calibrated for the range of temperatures and temperature differences encountered in the tests. The devices used for measuring the temperature difference shall be, Type T thermopiles, precision resistance thermometers separated or connected in two arms of a bridge circuit, precision thermistors separated or connected in two arms of a bridge circuit, matched type T thermocouples or other devices shown to be equal or better than those listed above. The temperature sensors shall be capable of measuring temperature differences within  $\pm 0.05^{\circ}\text{C}$  ( $\pm 0.09^{\circ}\text{F}$ ).

#### 6.2.4.2 Flow Measurements

The accuracy of the liquid flow rate measurement shall be equal to or better than 1.0% of the measured value in mass units per unit time.

#### 6.2.5 Automated Systems for Tracking Solar Calorimeter Tilt and Azimuth

It is advantageous to mount outdoor calorimeter cells in a rotating and/or gimbaled frame to allow the orientation of the calorimeter to track the sun as it moves through the sky. ANSI/NFRC 200 requires that the incident angle remain within  $5^{\circ}$  of the specified incident angle during the test. This can only be practically achieved by using an automated motorized system that can change the tilt and azimuth of the calorimeter to face the sun as it moves through the sky.

#### 6.3 Solar Radiation Measurement

The incident radiant flux shall be measured and recorded on a continuous basis throughout the test period at the minimum time interval specified in Section 7.34.

### **6.3.1 Solar Simulator Requirements**

The incident spectral distribution of an artificial light source used for indoor solar calorimeters shall be measured normal to the test specimen plane.

The spectral distribution of the artificial light standardized to match the irradiance on the test specimen plane shall be defined by the deviation from the global reference solar spectral irradiance for air mass 1.5 in accordance with ISO 9845-1. For the nine (9) wavelength ranges (300nm to 2500nm), the percentage of total irradiance is specified in Table 6-1.

The spectral match to all wavelength ranges, as specified in Table 6-1, shall be measured in accordance with IEC 60904-9 and shall be within 0.55 to 1.45 for the solar simulator to be considered suitable for testing.

**Table 6-1 – Global Reference Solar Spectral Irradiance Distribution**

<u>Wavelength Range (nm)</u>	<u>Percentage of Total Irradiance</u>
<u>300-400</u>	<u>4.6</u>
<u>400-500</u>	<u>14.1</u>
<u>500-600</u>	<u>15.4</u>
<u>600-700</u>	<u>14.0</u>
<u>700-800</u>	<u>11.3</u>
<u>800-900</u>	<u>9.4</u>
<u>900-1100</u>	<u>12.2</u>
<u>1100-1700</u>	<u>14.1</u>
<u>1700-2500</u>	<u>4.8</u>

### **6.3.16.3.2 Radiometer Requirements**

Pyranometers are radiometers used to measure the global short wavelength (solar) radiation incident on the test aperture and pyrhemometers are radiometers used to measure the direct beam solar irradiance. The characteristics of equipment for the measurement of irradiance are described in ISO 9060 and the World Meteorological Organization Guide to Meteorological Instruments and Methods of Observation. Only Section 4.3 of ISO 9060 (Secondary Standard Instruments) shall be used. The instruments specified in this procedure shall have the following minimum characteristics.

#### **6.3.1.16.3.2.1**          **Variation with Ambient Temperature**

During the test, the change in the instrument's response due to variations in ambient temperature shall be less than  $\pm 2\%$ . This characteristic shall be verified using a temperature curve determined for the specific instrument.

#### **6.3.1.26.3.2.2**          **Variation in Spectral Response**

Pyranometers shall have a constant sensitivity to within  $\pm 3\%$  over the spectral range from 0.35 to 1.5 micrometers.

#### **6.3.1.36.3.2.3**          **Nonlinearity of Response**

Unless the response of the pyranometer is within  $\pm 0.5\%$  of linearity over the range of irradiance existing during the test, the pyranometer shall be used with a calibration curve relating the output to the irradiance with an accuracy of  $\pm 0.5\%$ .

#### **6.3.1.46.3.2.4**          **Time Constant**

The time constant of the pyranometer, defined as the time required for the instrument to achieve a reading of 63.2% ( $I/I_0 = 1 - e^{-t/\tau}$ ). When  $t = \tau$ ,  $I/I_0 = (1 - 1/e) \approx 63.2\%$  of its final reading after a step change in solar irradiance, shall be less than 15 seconds.

#### **6.3.1.56.3.2.5**          **Variation with Angle of Incidence**

Ideally the response of the pyranometer is proportional to the cosine of the incident angle of the direct solar radiation and is constant at all azimuth angles. Unless the pyranometer's deviation from a true cosine response is less than  $\pm 10 \text{ W/m}^2$  ( $3.17 \text{ Btu/hr}\cdot\text{ft}^2$ ) for the incident angles encountered during the test(s), the pyranometer shall be used with the latest calibration curve relating the

response to the angle of incidence to correct for angular errors with accuracy within  $\pm 10 \text{ W/m}^2$  (3.17 Btu/hr-ft<sup>2</sup>).

#### **6.3.1.66.3.2.6 Variation with Tilt**

Unless the pyranometer response varies less than  $\pm 0.5\%$  for tilts ranging from horizontal to the largest tilt encountered during the test(s), the pyranometer shall be used with a calibration curve relating the response to the angle of inclination with an accuracy within  $\pm 0.5\%$ .

#### **6.3.1.76.3.2.7 Effects of Temperature Gradient**

The pyranometer used during the test(s) shall be placed in its test position and allowed to equilibrate for at least 30 minutes before the test commences.

#### **6.3.1.86.3.2.8 Calibration**

The pyranometer shall be calibrated for solar response within 12 months preceding the fenestration system test(s) against another pyranometer whose calibration uncertainty relative to recognized measurement standards is known. Any change of more than 1% over a one-year period shall warrant the use of more frequent calibration or replacement of the instrument. If the instrument is damaged in any significant manner, it shall be re-calibrated or replaced. All calibrations shall be performed using ASTM E 824 at normal incidence (Type C) and at a tilt angle of  $40^\circ \pm 20^\circ$  from horizontal.

#### **6.3.1.96.3.2.9 Sample Plane Pyranometer**

A pyranometer shall be used to measure the incident irradiance on a plane parallel to the test aperture. It shall have the same minimum operating characteristics as listed above for a pyranometer.

#### **6.3.1.106.3.2.10 Horizontal Pyranometer**

A horizontal pyranometer may be used to measure the global horizontal (beam plus diffuse) irradiance.

### **6.4 Measurement of Ambient Conditions**

The air temperature and wind speed and direction shall be measured and reported for the duration of the test.

#### **6.4.1 Exterior Air Temperature Instrumentation**

The ambient air temperature near the solar calorimeter shall be measured in at least one location at a distance not to exceed 2 meters (6 feet) from the solar calorimeter. The ambient air temperature sensors shall be placed in locations that are shaded from direct solar irradiation.

#### **6.4.2 Wind Speed and Direction**

The wind speed and direction near the solar calorimeter shall be measured in at least one location at a distance not to exceed 2 meters (6 feet) from the calorimeter (This measurement shall not be required for indoor or enclosed calorimeters).

#### **6.4.3 Measured Weather Side Surface Heat Transfer Coefficient**

The surface heat transfer coefficient on the surface parallel with the test specimen shall be measured while the test is in progress using a unique device described in Annex A1. The outdoor surface heat transfer coefficient measured by the Solar-Air Heat Transfer Coefficient Meter shall be used in the calculation of the overall heat flux through the test specimen during the test based on the temperature difference between the inside and the outside and the Modified thermal transmittance (See Section 8.5.1.1).

---

## **7. TEST PROCEDURE**

---

### **7.1 Test Specimen Installation**

#### **7.1.1 Test Specimen Preparation**

Before the test specimen is installed in the calorimeter, the laboratory shall inspect the fenestration product for damage and compare the dimensions of the product to the working drawings supplied by the manufacturer. The test laboratory shall also measure the glazing deflection of all the insulated glass units in the fenestration product using the procedure outlined in ASTM E 1423. The glazing deflection(s) and any discrepancies between the test specimen and the working drawings shall be recorded and reported in the test report.

#### **7.1.2 Test Specimen Installation**

Test specimens shall be installed in surround panels that have been previously characterized using the calibration test procedures specified in Section 5. Surround panels shall be constructed and instrumented as specified in Annex F. The test specimen shall be mounted in the surround panel as it is intended to be installed in actual end use. That is, the complete assembly including all frame elements shall be in place during the test. The outside surface of the test specimen frame shall be flush with the outside surface of the surround panel in the calorimeter. The test specimen and any cracks or holes in the product shall be sealed for air infiltration to the specifications in Section 7.2.3 using tape or caulk. Specific guidelines for installing Tubular Daylighting Devices are presented in Annex G.

A solar calorimeter can be used to measure the SHGC of the glazing alone (center-of-glazing SHGC). This test method proposes a standard procedure of installing the glazing unit in a surround panel for this purpose. In this circumstance, the glazing unit shall be mounted and sealed into a 100 mm (4.0 in) thick surround panel with an aperture of 1.0 m by 1.0 m (39 in by 39 in). At a minimum, the entire perimeter of the glazing unit shall be inset 13 mm (0.5 in) deep into the surround panel, but if a spacer is used, the unit shall be inset into the surround panel so that the inner edge of the spacer is flush with the site line of the surround panel. In addition, the outer face of the glazing unit shall be recessed 13 mm (0.5 in) from the outside face of the surround panel. Any glazing stops shall be manufactured from surround panel material and shall be caulked or cemented in place. The exposed glazing unit area,  $A_s$ , shall be representative of center-of-glazing of the product. If the product cannot be manufactured in the exact size specified or is modular in nature, then use the procedure in Section 4.3.2.2 of ANSI/NFRC 100 to determine the product test size.

### 7.1.3 Test Specimen Air Leakage

All potential air leakage sites on the test specimen and at the interface between the surround panel and the test specimen, shall be sealed with tape and/or caulking as close to the primary seal as possible to minimize or eliminate air leakage between the interior of the solar calorimeter and ambient air. The tape and/or caulking shall have a similar surface emittance ( $\pm 0.1$ ) and solar ~~absorptance~~ absorptance ( $\pm 0.1$ ) as the test specimen or surround panel surface to which it is attached. If metal tape is used, the outer surface shall be painted or covered with tape so that the surface emittance and solar ~~absorptance~~ absorptance

**absorptance** is similar to ( $\pm 0.1$ ) the surface to which it is attached. The method and placement of the air seal can affect the thermal performance of the test specimen. Therefore, the test specimen shall be sealed at the exterior side of the surround panel with tape, caulking or other material of similar surface emittance and solar absorptance to that of the adhering surface. If the surround panel is assembled from different pieces of the same material, the joints between surround panel pieces shall be sealed on both sides of the surround panel. In no case shall the tape or caulk cover more than 50 mm (2 in) of each surround panel edge.

**Note:** As an additional precaution to minimize the potential for leakage of air through and around the sealed test specimen, means may be provided to measure and equalize the pressure difference across the test specimen. See Section 7.1.3 of ASTM E 1423 for additional information on how to equalize the pressure difference across the test specimen.

#### 7.1.4 Test Specimen Instrumentation

Since the surface temperature of the test specimen is not used in calculating the measured Solar Heat Gain Coefficient of the test specimen, there is no requirement to place temperature sensors on the specimen. At a minimum, many laboratories attempt to measure and report the center-of-glazing temperatures on both sides of the glazing unit or the fenestration attachment, but surface temperatures of transparent objects in direct sunlight can be difficult to accurately measure. Since some laboratories may report glazing or whole product surface temperatures measured during the test, guidance is given as to how to consistently apply and measure surface temperatures of test specimens in solar calorimeters.

#### 7.1.5 Test Specimen Average Surface Temperature

To determine the average surface temperature of the test specimen, it is necessary to make temperature measurements on both sides of the test specimen frame, glazing (center and near edges) and on any other surfaces (sills, muntins, etc.) in order to provide a representative area weighted value of the surface temperature of the specimen. It must be recognized that there is such a wide range of fenestration system designs that it is not possible to specify the locations of the temperature sensors to provide a correct area weighted determination of the

various surface temperatures for all configurations. See ANSI/NFRC 100 or ASTM E 1423 for additional guidance on the location of test specimen surface temperature sensors for different fenestration systems. The weighted heat transfer surface areas used with the frame/sash temperature measurements shall add up to the total surface area of the frame/sash in contact with the surrounding air.

All surface temperature-measurements shall be made using the temperature sensor attachment techniques and area weighing criteria specified in Section 6.5.3 of ASTM C 1199. The test specimen surface temperature sensor wires shall be led in such a way as to minimize the disturbance to the air flow and solar radiation incident on the test specimen.

- A. When attaching temperature sensors (i.e., thermocouples) to frame and sash surfaces, the emittance and solar absorptance of the tape or glue shall be similar ( $\pm 0.1$ ) to the emittance and solar absorptance of the surface to which it is attached.
- B. When attaching temperature sensors to glazing, the emittance of the tape or glue shall be similar to ( $\pm 0.1$ ) the emittance of the glazing surface to which it is attached and be visually transparent. The tape or glue used to attach temperature sensors to glazing shall not be more than 12 mm (0.5 in) wide but be at least 100mm (4 in) long.

Note: Accurately measuring the temperature differential across insulating glazing units can be very difficult due to the impact of absorbed solar radiation on the measurement device. The best method is to use temperature measurement devices that are as small as possible. Some test operators report success with using 30-gauge thermocouple wire with 100 mm (4 in) of insulation removed from the measurement junction and then secured to the glazing with "Sunshine Glue" (clear cement that cures with UV light or sunshine).

#### **7.1.6 Test Specimen Thermal Transmittance**

The U-factor for the test specimen shall be determined using ASTM C 1199 or ANSI/NFRC 100.

## **7.2 Test Conditions**

### 7.2.1 General

Wherever the incident solar irradiation conditions, temperatures and standard heat transfer coefficients are not otherwise specified, ASTM E1423 or ANSI/NFRC 200 shall be used as a guide for selecting the appropriate test conditions.

### 7.2.2 Incident Solar Irradiation

One pyranometer mounted in the test sample plane shall be used to measure the incident global solar irradiance during the test. The irradiance measured during each test shall not vary from the average value by more than 5%. The incident irradiance shall be uniform over the surface of the test specimen for the duration of the test.

#### ~~7.2.2.1 Incident Angle Tolerance~~

The SHGC of glazing systems and fenestration shading systems will vary with the incident angle of the source of irradiation. For this reason, fenestration rating systems, such as NFRC or CSA, often specify a range or tolerance for the incident angle for the duration of the test measurement period. This is not an issue for solar calorimeters located indoors, which are illuminated by a fixed artificial light source, but solar calorimeters located outdoors usually need a tracking mechanism to change the orientation and tilt of the solar calorimeter to follow the sun as it moves across the sky.

#### ~~7.2.2.2 Indoor Light Source (Artificial Sunlight)~~

~~The incident spectral distribution of an artificial light source used for indoor solar calorimeters shall be measured normal to the test specimen plane. The shape of the incident spectral irradiance shall not depart from the standard solar spectral distribution at an air mass of 1.5 specified in ASTM E 1585 or NFRC 300 by more than 10% at any wavelength, with the exception of narrow spectral lines where the total energy from all spectral lines is less than 5% of the total radiant flux.~~

~~A. The shape of each spectrum shall be determined by normalizing each to its value at the wavelength of peak spectral irradiance.~~

~~B. The comparison of shapes shall be made on a wavelength-by-wavelength basis. When the source spectrum has no value at a wavelength~~

~~in the standard spectrum, a value at that wavelength shall be calculated by linear interpolation.~~

### **7.2.3 Ambient Temperature**

The ambient temperature outside of the solar calorimeter shall be recorded and shall not vary more than  $\pm 5.0^{\circ}\text{C}$  ( $\pm 9.0^{\circ}\text{F}$ ) over the duration of a test.

~~7.2.3.1~~ The ambient temperature outside of the solar calorimeter shall be recorded and shall not vary more than  $\pm 5.0^{\circ}\text{C}$  ( $\pm 9.0^{\circ}\text{F}$ ) over the duration of a test.

### ~~7.2.3.1~~ **7.2.3.2 Indoor Solar Calorimeter Ambient Temperature**

Solar calorimeters located indoors shall maintain an exterior air temperature within  $\pm 1.0^{\circ}\text{C}$  ( $\pm 1.8^{\circ}\text{F}$ ) of the set point over the duration of a test.

### **7.2.4 Exterior Wind Conditions**

The wind speed and direction shall be measured at a location not to exceed 2 meters (6 feet) from the solar calorimeter.

#### **7.2.4.1 Indoor Solar Calorimeter Exterior Wind Conditions**

Solar calorimeters located indoors need external fans to provide a minimum air flow on the outside of the test specimen and surround panel during test periods. The airflow shall be directed either perpendicular or parallel to the plane of the test specimen in such a way that the velocity is uniform over the surface of the test specimen when measured at a distance of 100 mm (4 in) from the surround panel. In the absence of other standards, the air velocity shall be  $3.4 \pm 0.1$  m/s ( $7.5 \pm 0.2$  mph).

#### **7.2.4.2 Outdoor Solar Calorimeter Exterior Wind Conditions**

Solar calorimeters located outdoors shall measure the weather side surface heat transfer coefficient during the test using the Solar-Air Heat Transfer Coefficient Meter described in Annex A. The Solar-Air Heat Transfer Coefficient Meter shall not be used if the incident angle of the sun is greater than  $60^{\circ}$  from normal to the surface.

### **7.2.5 Interior Conditions Inside Solar Calorimeter**

There shall be no more than 2.0°C (3.8°F) of temperature stratification per meter from top to bottom of the interior height of the solar calorimeter measured along the plane parallel to the surround panel and at a distance of 75 mm (3 in) from the surround panel surface. Small fans may be placed inside the chamber in order to induce mixing and a uniform air flow across the test specimen. The air flow inside the calorimeter shall be less than 0.3 m/s (0.7 mph) when measured 75 mm (3 in) from the inside surface of the surround panel.

### **7.2.6 Fluid Flow Heat Extraction and Control**

The air temperature within the calorimeter is controlled through the combined use of a heat exchanger and fluid circulation loop. The heat exchanger functions to remove a metered quantity of heat in order to maintain the interior cell air and surface temperatures at the desired state. In the case of a liquid circulation loop, this is accomplished by controlling fluid inlet temperature and flow rate.

- A. The fluid flow rate shall remain within  $\pm 5.0\%$  of the average flow rate for the duration of the test.
- B. The inlet fluid temperature shall remain within  $\pm 1.0^\circ\text{C}$  ( $\pm 1.8^\circ\text{F}$ ) of the average inlet fluid temperature for the duration of the test.

The instantaneous Solar Heat Gain Coefficient shall be calculated at each measurement interval.

For tests performed at a constant incident angle (i.e., ANSI/NFRC 200) The Solar Heat Gain Coefficient shall not vary more than 2% for the duration of the test.

## **7.3 Determination of Steady-State Conditions**

Establish steady-state solar irradiance, temperature and power conditions for which the test specimen is to be tested and record measurements of solar irradiance, temperatures, power, flow rate, wind velocity and direction. Steady-state is achieved when the test conditions specified in Section 7.3 have been met for a period of 5 continuous time constants of the calorimeter, surround panel and test specimen. The time constant of the solar calorimeter and surround panel can be determined using the procedure specified in Section E. The measured SHGC shall not change monotonically during the test period.

Measurements of solar irradiance, temperatures, power, flow rate, wind velocity and direction shall be recorded at a minimum of 1 minute intervals.

## 8.1 General Description of Calculation Procedure

8. **CALCULATION PROCEDURE** Solar calorimetry relies on thermal measurements made on the inside and outside of the shell of a calorimeter cell (control boundary), which includes the test specimen, calorimeter enclosure and associated equipment for measurement and control of the interior and exterior climatic conditions. Taking into account all the measurements specified in Sections 5 and 6, the heat flux through the test specimen,  $Q_S$ , shall be determined by the following equation:

$$Q_S = Q_{Walls} + Q_{SP} + Q_{fl} + Q_{fluid} + Q_{AUX} \quad \text{Equation 8-1}$$

Where

- $Q_S$  = Heat flux through test specimen, W (Btu/h)
- $Q_{Walls}$  = Heat flux through solar calorimeter walls, W (Btu/h)
- $Q_{SP}$  = Heat flux through surround panel, W (Btu/h)
- $Q_{fl}$  = Heat flux by flanking loss as determined in Section 5.2.2.1, W (Btu/h)
- $Q_{fluid}$  = Heat removed by fluid heat extraction system, W (Btu/h)
- $Q_{AUX}$  = Heat input into solar calorimeter by pumps and fans, W (Btu/h)

- H. The SHGC, which is the ratio of the incident irradiation to the heat gain through the test specimen shall be calculated using the following equation:

$$SHGC = \frac{Q_S - Q_{U-factor}}{A_S E_S} \quad \text{Equation 8-2}$$

Where

- SHGC = Solar Heat Gain Coefficient of test specimen, dimensionless
- $Q_{U-Factor}$  = Heat flux due to air temperature difference (Thermal Transmittance) of test specimen, W/m<sup>2</sup>K (Btu/h·ft<sup>2</sup>·°F)
- $A_S$  = Projected area of test specimen, m<sup>2</sup> (ft<sup>2</sup>)
- $E_S$  = Solar irradiation incident on the test specimen, W/m<sup>2</sup> (Btu/h·ft<sup>2</sup>)

## 8.2 Heat Transfer through Solar Calorimeter Shell

### 8.2.1 Solar Calorimeter Walls, $Q_{Walls}$

The heat flow through the solar calorimeter walls is a function of the measured temperature difference on both sides of the solar calorimeter walls as described in Sections 6.2.2.5. The temperature difference measurement is multiplied by the conductance-area coefficient of the wall,  $UA_{Wall}$ , as determined by Section 5.2.1. The heat flow through the solar calorimeter walls shall be determined by the following equation:

$$Q_{Walls} = UA_{Walls} \cdot \Delta T_{Walls} \quad \text{Equation 8-3}$$

or

$$Q_{Walls} = UA_{Walls} \cdot EMF_{Walls} \quad \text{Equation 8-4}$$

Where

- $UA_{Walls}$  = Conductance-Area of Solar Calorimeter Walls, W/K (Btu/hr<sup>°</sup>F)
- $T_{Walls}$  = Temperature Difference across Solar Calorimeter Walls, ° K or °C (R or °F)
- $E.M.F._{Walls}$  = Output from Thermopile Measuring the Temperature Difference across Solar Calorimeter Walls, K or °C (R or °F).  
Note EMF is converted to temperature equivalence

### 8.2.2 Surround Panel, $Q_{SP}$

The heat flow through the surround panel is a function of the measured temperature difference on both sides of the surround panel as described in Section 6.2.3. It is also a function of both the thermal conductance of the surround panel,  $C_{SP}$ , as determined using the methods specified in Section 5.2.1 and the projected area of the face of the surround panel,  $A_{SP}$ , as measured by the testing laboratory. The heat flow through the surround panel shall be determined by the following equation:

$$Q_{SP} = C_{SP} + A_{SP} (t_{SPh} - t_{SPc}) \quad \text{Equation 8-5}$$

Where

- $C_{SP}$  = Conductance of Surround Panel, W/m<sup>2</sup>K (Btu/h·ft<sup>2</sup>·°F)
- $A_{SP}$  = Area of Surround Panel, m<sup>2</sup> (ft<sup>2</sup>)
- $t_{SPh}$  = Temperature of Interior Surface of Surround Panel, K or °C (R or °F)
- $t_{SPc}$  = Temperature of Exterior Surface of Surround Panel, K or °C (R or °F)

### 8.2.3 Flanking Loss, $Q_{fl}$

The flanking loss heat flow through the surround panel is a function of the surround panel thickness and construction and is determined using the process described in Annex C. The flanking loss heat flow may also be a function of the air temperature or velocity inside or outside of the solar calorimeter or the surface temperatures of the surround panel and should be adjusted for such based on previous calibration measurements.

## 8.3 Heat Removal by Fluid Heat Extraction System

### 8.3.1 Fluid Heat Extraction System, $Q_{fluid}$

The absorber plate inside of the solar calorimeter contains a fluid heat extraction system that removes much of the heat absorbed by the solar calorimeter. The heat extracted by the fluid heat extraction system is a function of the properties of the fluid,  $\Delta T$  and  $C_P$ , the volumetric flow rate of the fluid,  $f$  and the inlet and exit fluid temperature difference,  $(t_e - t_i)$ . Equation 6-1 in Section 6.2.4 shall be used to determine the heat extracted by the fluid heat extraction system:

$$Q_{fluid} = \rho + C_P \cdot f \cdot (t_e - t_i) \quad \text{Equation 8-6}$$

Where

- $\rho$  = fluid density at constant pressure,  $\text{Kg/m}^3$  ( $\text{lb/ft}^3$ )
- $C_P$  = specific heat at constant pressure,  $\text{W/Kg}\cdot\text{K}$  ( $\text{Btu/h}\cdot\text{lb}\cdot^\circ\text{F}$ )
- $f$  = fluid volumetric flow rate,  $\text{Kg/h}$  ( $\text{lb/h}$ )
- $t_e$  = exit fluid temperature,  $\text{K}$  or  $^\circ\text{C}$  ( $\text{R}$  or  $^\circ\text{F}$ )
- $t_i$  = inlet fluid temperature,  $\text{K}$  or  $^\circ\text{C}$  ( $\text{R}$  or  $^\circ\text{F}$ )

## 8.4 Heat Input by Fans and Pumps

### 8.4.1 Heat Input by Fans and Pumps, $Q_{AUX}$

There may be pumps or fans located inside the solar calorimeter to help minimize the temperature gradients in the air and on the absorber plate. Also, some instrumentation (i.e., hot wire anemometers) can be a source of heat input. All the power used by these auxiliary devices located inside of the solar calorimeter shall be measured and recorded for the duration of the test. Typically, this is best performed by solid-state linear integrators, but the integration of frequent measurements of the voltage and amperage used by these auxiliary devices can alternatively be used.

## 8.5 Heat Transfer Through the Test Specimen, $Q_{U-factor}$

There are two methods used to calculate the heat transfer through the test specimen due to the air temperature difference across the test specimen. One method uses the standardized thermal transmittance as determined by ASTM C 1199, ANSI/NFRC 100 or the results from regression analysis of the measurements from this test. This method is more appropriate for use in indoor solar calorimeters, where the exterior surface heat transfer coefficient can be held relatively constant at a value close to the standardized surface heat transfer coefficient. The other uses the modified thermal transmittance as determined by ASTM C 1199 or NFRC 102. This method is best for solar calorimeters that are located outdoors and are subjected to variable exterior wind conditions. Although either method is permitted, the test report shall identify which method was used to calculate the reported SHGC values.

### 8.5.1 Standardized Thermal Transmittance, $U_{ST}$

The Standardized thermal transmittance can be used to calculate the heat transfer through the test specimen due to the air temperature gradient across the test specimen. ASTM C 1199 or ANSI/NFRC 100 shall be used to determine the Standardized thermal transmittance,  $U_{ST}$ , of the test specimen except as noted in Section 8.5.1.2. The Standardized thermal transmittance shall be multiplied by the projected area of the test specimen,  $A_S$  and the air temperature difference,  $(t_h - t_c)$ , across the test specimen using the following equation:

$$Q_{U-factor} = U_{ST} \cdot A_S (t_h - t_c) \quad \text{Equation 8-7}$$

Where

- $U_{ST}$  = Standardized thermal transmittance of test specimen,  $W/m^2K$  ( $Btu/h \cdot ft^2 \cdot ^\circ F$ )
- $A_S$  = Projected area of test specimen,  $m^2$  ( $ft^2$ )
- $t_h$  = Air temperature inside solar calorimeter,  $K$  or  $^\circ C$  ( $R$  or  $^\circ F$ )
- $t_c$  = Air temperature outside solar calorimeter,  $K$  or  $^\circ C$  ( $R$  or  $^\circ F$ )

This method is more appropriate for use in indoor solar calorimeters, where the exterior wind velocity and direction can be controlled. The wind velocity shall be held at a value that produces an exterior surface heat transfer coefficient,  $h_c$ , that is within  $\pm 10.0\%$  of the standardized weather side surface heat transfer coefficient,  $h_{STc}$ , listed in Section 6.2.2 of ASTM E 1423.

### 8.5.1.1 Modified Thermal Transmittance, $U_M$

In solar calorimeters located outdoors, the heat transfer due to the temperature difference across the test specimen shall be determined in way that accounts for the variations in the exterior surface heat transfer coefficient that occur with the changes in outside wind speed and direction. The standardized thermal transmittance,  $U_{ST}$ , (ASTM C 1199 or ANSI/NFRC 100) shall be modified by removing the standardized weather side surface heat transfer coefficient,  $h_{STc}$ , (See Section 6.2.2 of ASTM E 1423). The modified thermal transmittance,  $U_M$ , which is the thermal transmittance of the test specimen in the absence of the exterior surface heat transfer coefficient, shall be calculated using the following equation:

$$U_m = \frac{1}{\frac{1}{U_{ST}} - \frac{1}{h_{STc}}} \quad \text{Equation 8-8}$$

Where

- $U_M$  = modified thermal transmittance of test specimen, W/m<sup>2</sup>K (Btu/h·ft<sup>2</sup>·°F)  
 $h_{STc}$  = weather side surface heat transfer coefficient, W/m<sup>2</sup>K (Btu/h·ft<sup>2</sup>·°F)

### 8.5.1.2 Measured Weather Side Surface Heat Transfer Coefficient, $h_{h-sun}$

The modified thermal transmittance shall be used to determine the total thermal transmittance of the test specimen during the test once the exterior surface heat transfer coefficient,  $h_{h-sun}$ , as measured on the Solar-Air Heat Transfer Coefficient Meter, is known. The Solar-Air Heat Transfer Coefficient Meter is described in greater detail in Annex A. In essence, the Solar-Air Heat Transfer Coefficient Meter measures the surface temperature of a metal surface painted black, which is in the same plane and with a similar exposure to sunlight and wind as the test specimen. The temperature of the black plate shall be used to calculate the exterior surface heat transfer coefficient using the following equation:

$$h_{h-sun} = \frac{E_s \cdot \alpha_{plate}}{t_{plate} - t_c} \quad \text{Equation 8-9}$$

Where

- $h_{h-sun}$  = measured weather side surface heat transfer coefficient, W/m<sup>2</sup>K (Btu/h·ft<sup>2</sup>·°F)

- $\alpha_{plate}$  = solar absorptance of Solar-Air Heat Transfer Coefficient Meter
- $t_{plate}$  = temperature of Solar-Air Heat Transfer Coefficient Meter, °C (°F)
- $E_S$  = solar irradiation incident on specimen, W/m<sup>2</sup> (Btu/h·ft<sup>2</sup>)

### 8.5.1.3 Total Measured Thermal Transmittance

The exterior surface heat transfer coefficient,  $h_{h-sun}$ , as measured by the Solar-Air Heat Transfer Coefficient Meter shall be combined with the modified thermal transmittance,  $U_M$ , to determine the standardized thermal transmittance using the following equation:

$$U_{ST} = \frac{1}{\frac{1}{h_{h-sun}} - \frac{1}{U_M}} \quad \text{Equation 8-10}$$

## 8.6 Solar Irradiation Incident on the Test Specimen, $E_S$

A pyranometer shall be mounted in the same plane and with the same exposure to sunlight as the test specimen to measure the solar irradiation incident on the test specimen. The output from the pyranometer shall be multiplied by its calibration constant to determine the solar energy incident on the test specimen using the following equation:

$$E_S = V_{PSP} P_{PSP} \quad \text{Equation 8-11}$$

Where

- $V_{PSP}$  = millivolt output from pyranometer, mV
- $P_{PSP}$  = pyranometer calibration constant, W/m<sup>2</sup>·mV (Btu/h·ft<sup>2</sup>·mV)

**Note:** The pyranometer calibration constant is one of the most important calibrations that need to be properly and frequently performed in order to accurately calculate SHGC values. Previous comparisons of solar calorimeter results from different laboratories have shown that the measurement of incident solar irradiation has a strong influence on the final SHGC results. In addition, the calibration constant for some PSP type pyranometers has been shown to change over time. For these reasons, the pyranometers used for calculating the SHGC must be frequently calibrated at a reputable laboratory (a minimum of one time per year).

## 8.7 Calculation of Solar Heat Gain Coefficient

### 8.7.1 Data Collection and Analysis

Unlike most ASTM thermal transmittance or conductance tests in which the temperatures and heat flows eventually become constant, an outdoor solar calorimeter is unlikely to be at steady-state conditions for a long period of time. For this reason, the raw data gathered from solar calorimeters is not averaged before it is analyzed. Instead, the heat balance and SHGC are calculated for each measurement interval and the SHGC results are usually plotted in respect to the incident angle or the profile angle of the incident sunlight. If the measured SHGC does not drastically vary over a period of the test as in a solar calorimeter that tracks the sun to maintain a constant incident angle, then those SHGC results may be averaged over the period in question. Nevertheless, the SHGC is calculated from each set of instantaneous raw data collected before it is averaged.

#### 8.7.1.1 Heat Balance Equation, $Q_s$

Once the required variables are measured, the heat balance for the solar calorimeter shell shall be determined using Equation 8-1 in Section 8.1.

#### 8.7.1.2 Calculation of Solar Heat Gain Coefficient, SHGC

Once the heat balance equation is solved, the SHGC for the test specimen shall be determined using Equation 8-2 in Section 8.1 and plotted in relation to the incident angle or profile angle of the incident solar irradiation.

## 9. TEST REPORT

---

### 9.1 Reported Data

Report results per NFRC 701.05 [9].

### 9.2 Uncertainty Estimation

The individual laboratory measurement uncertainty of this test method depends upon the test equipment and operating procedures and upon the test conditions and specimen properties. For this reason, no simple quantitative statement can be made that will apply to all tests; however, in order to comply with the requirements of Section 9.1.U, it is necessary to estimate the uncertainty of the results for each test to

be reported. Such estimates of uncertainty can be based upon an analysis using the propagation of errors theory (often called uncertainty analysis) discussed in textbooks on engineering experimentation and statistical analysis. These uncertainty estimates can be augmented by the results of inter-laboratory test comparisons, by the results of experiments designed to determine repeatability of the effect of deviations from design test conditions and by measurements of reference specimens from appropriate standards laboratories. In general, the best overall accuracy will be obtained in an apparatus with low solar calorimeter wall heat transfer, low surround panel heat transfer and low flanking (surround panel and surround panel frame) heat transfer relative to the test specimen heat transfer. Low solar calorimeter wall heat transfer can be achieved by using highly insulated walls subjected to small temperature differences. Low surround panel heat transfer can be achieved with highly insulated surround panels that have a small exposed surface area in relation to the metering chamber aperture area. Low surround panel and surround panel frame flanking heat transfer, in relation to metering box heat input, can be achieved by using homogeneous and highly insulated surround panels and surround panel frames with no thermal bridges. Also, in general, for a particular apparatus, the uncertainty will decrease as the heat transfer through the specimen increases.

---

## 10. PRECISION AND BIAS

---

There is no Precision and Bias Statement for this procedure until round robin comparisons can be conducted.

## 11. KEYWORDS

---

---

calorimeter; doors; fenestration; heat; hot box; solar; SHGC; solar calorimeter; skylights; U-factor; windows

---

**ANNEXES**  
**(MANDATORY INFORMATION)**

**A. Solar-Air Heat Transfer Coefficient Meter**

A1. Description of Solar-Air Heat Transfer Coefficient Meter

The exterior surface heat transfer coefficient of the test specimen can be measured during the test using the Solar-Air Heat Transfer Coefficient Meter, which is described in this annex. By measuring the surface temperature of an insulated black metal plate,  $t_{\text{plate}}$ , exposed to the same sunlight, ambient air flow and temperature as the face of the solar calorimeter, the exterior surface heat transfer coefficient of the test specimen,  $h_{\text{sun}}$ , is estimated at the time of measurement. The use of the measured temperature from this device to calculate the instantaneous SHGC is described in Section 8.5.1.2. Although the use of this device is optional, it must be constructed to the specifications in this annex if it is to be used. This device cannot be used if the incident angle of the sun is greater than 60° from normal to the front surface.

A2. Construction and Installation of Solar-Air Heat Transfer Coefficient Meter

A2.1 General Description

A thermocouple is attached to the back side of a thin, square aluminum or copper plate measuring  $150 \pm 50$  mm ( $6.0 \pm 2.0$  in) by  $150 \pm 50$  mm ( $6.0 \pm 2.0$  in). That plate is painted black on one side and adhered to a piece of  $100 \pm 12$  mm ( $4.0 \pm 0.5$  in) thick polystyrene foam of the same dimensions (see Figure 11-1). The apparatus is then mounted on the top of the solar calorimeter so that the black metal plate is in the same plane as the face of the solar calorimeter.

**Figure 11-1 -- Solar-Air Heat Transfer Coefficient Meter**

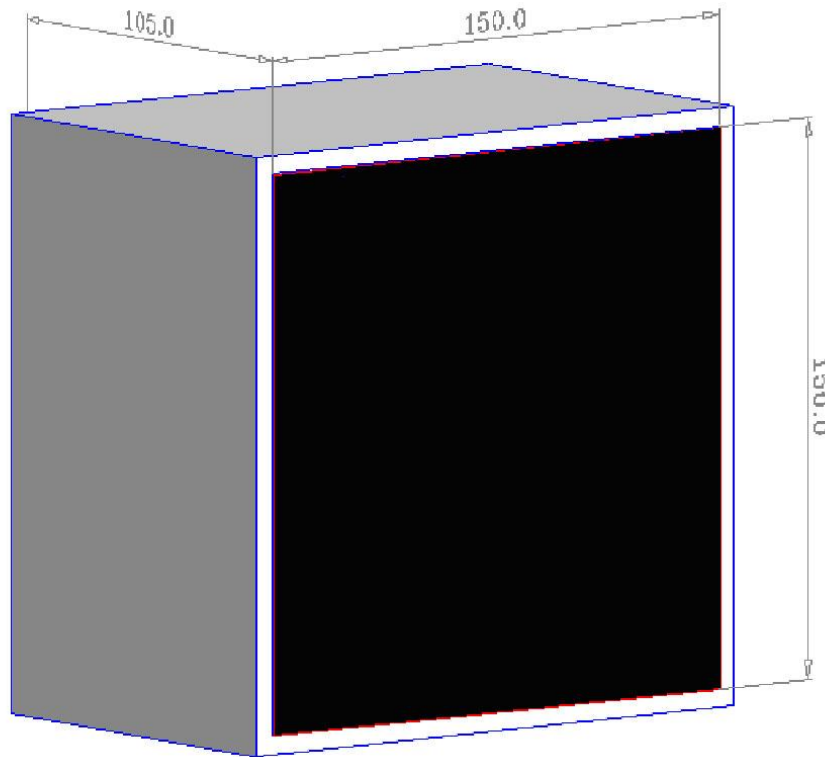

## A2.2 Metal Plate and Instrumentation

Prepare and clean a  $1.0 \text{ mm} \pm 0.25 \text{ mm}$  ( $0.04 \text{ in} \pm 0.01 \text{ in}$ ) thick copper or aluminum plate measuring  $150 \text{ mm} \pm 50 \text{ mm}$  by  $150 \text{ mm} \pm 50 \text{ mm}$  ( $6.0 \text{ in} \pm 2.0 \text{ in}$  by  $6.0 \text{ in} \pm 2.0 \text{ in}$ ). The plate must be square. Paint one side flat black so that the solar absorptance is  $0.95 \pm 0.05$  and the emittance is  $0.9 \pm 0.1$ . An initial application of metal primer covered with multiple coats of black paint is recommended. It is also recommended to paint the surface after the thermocouple has been attached to the back of the metal plate as described in Sections A1 or A2.1.

### A2.2.1 Aluminum Plate

If the plate is made from aluminum, the back side must be prepared for the attachment of the thermocouple. The bare metal of the thermocouple wire cannot be in electrical contact with the

aluminum plate, but must be in good thermal contact with the surface. Therefore, the aluminum must be painted with a thin, hard coating at the location where the bare thermocouple wire is to be in contact (clear nail polish or liquid insulation paint has been used with success for this purpose). The 30 gage thermocouple shall be prepared by stripping at least 38 mm (1.5 in) of the wire bare before making the junction (bead). Configure the bare wire into a flat circle about 25 mm (1 in) in diameter. Once the insulation coating on the aluminum plate has cured, the bare thermocouple wire is adhered to the aluminum plate so that the bead is centered on the back face of the plate (see Figure 11-2). In addition, glue at least 75 mm (3 in) of the insulated wire to the metal plate (initially adhering the wire to the surface with dots of superglue and then coating the entire thermocouple wire with a thin layer of high-conductance epoxy has been shown to work for this application).

**Figure 11-2 -- Thermocouple attached to back side of aluminum plate**

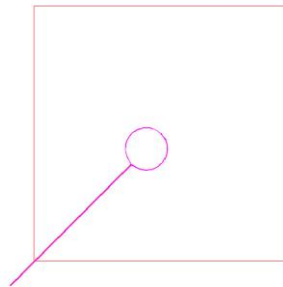

#### A2.2.2 Copper Plate

The thermocouple wire can be attached to a copper plate as described in the previous Section A2.2.1, but it can also be directly soldered to the copper plate. Clean an area about 50 mm (2 in) in diameter in the center of the copper plate with etching fluid or flux. Prepare Type T thermocouple wire (copper-constantan) by stripping 12 mm (0.5 in) of insulation off both leads. Solder both of the bare leads of thermocouple wire to the copper plate so that the constantan wire is centered in the

middle of the back face of the plate. The copper wire shall be soldered so that it is at least 12 mm (0.5 in) from the location where the constantan wire is attached. Glue at least 75 mm (3 in) of the insulated wire to the metal plate.

### A2.3 Foam Insulation

The black metal plate is attached to foam insulation so that the thermocouple is located between the plate and the foam. The foam insulation must have a thermal conductivity at 24°C (75.2°F) not in excess of 0.04 W/mK (0.02 Btu/h·ft°F) and having a very low gas permeance. The foam shall have the same dimensions as the black metal plate, but shall be at least 100 mm (4.0 in) thick. The metal plate can be adhered to the foam using water-based contact cement or other adhesive that will not damage the foam. The remaining exposed edges of the foam should be protected against weather by painting or covering with a thin-walled five-sided box made from plywood or plastic that has a solar absorptance less than 0.2 on the exposed surfaces. Again, insure that the paint or covering does not damage the foam.

### A2.4 Installation

The assembled metal plate, thermocouple and foam shall be mounted on top of the calorimeter in such a way so that the face of the black metal plate is in the same plane as the face of the solar calorimeter. The metal plate shall be centered over the test specimen and there should be no obstructions of the air flow up the test specimen, across the surround panel and the Solar-Air Heat Transfer Coefficient Meter. The thermocouple shall be connected to the data acquisition system so that a temperature measurement is performed at the same time that the measurements from the solar calorimeter are collected.

## **B. Calibration of Solar Calorimeter Wall Heat Flux**

### B1. Calibration of Solar Calorimeter Wall Heat Flux

The heat flux through the solar calorimeter walls can be estimated by various means, which differ in accuracy and level of effort. The heat flux of the calorimeter shall be estimated during the design of the calorimeter to refine the final construction. In addition, the predicted heat flow can then be compared to the actual values measured by means specified in

this Annex as a gauge of meeting the design goals. The procedures described below assume that the solar calorimeter is designed to have generally uniform airflow and temperatures at each surface of the calorimeter walls.

## B2. Model Prediction

The following equations represent one method of estimating the heat flow through the walls of a five-sided rectangular calorimeter made of homogeneous material. Langmuir estimates the solar calorimeter wall heat flow to be equivalent to one-half that of a closed six sided box formed by placing two of the open sided boxes together. The heat flow for the five-sided box is given by:

$$q = \frac{\lambda_{eff} A_{eff} (t_{in} - t_{out})}{L} \quad \text{Equation 11-1}$$

Where, the effective area normal to heat flow,  $m^2$ , is given by:

$$A_{eff} = A_{in} + 0.54 \cdot L \cdot \Sigma e_i + 0.60 \cdot L^2 \quad \text{Equation 11-2}$$

And,

$A_{in}$	=	solar calorimeter inside surface area, $m^2$ ( $ft^2$ )
$L$	=	solar calorimeter wall thickness, m (ft)
$\lambda_{eff}$	=	solar calorimeter effective wall thermal conductivity, W/mK (Btu/hr·ft·°F)
$t_{in}$	=	solar calorimeter inside wall surface temperature, K or °C (R or °F)
$t_{out}$	=	solar calorimeter outside wall surface temperature, K or °C (R or °F)
$\Sigma e_i$	=	sum of all (total of 8) solar calorimeter interior edge lengths formed where two walls meet, m (ft)

There are numerous two-dimensional computer analysis tools that can be used to estimate the heat flow through the calorimeter walls (i.e., THERM). Typically, these computer programs require detailed cross sections of the solar calorimeter wall at all locations that are representative of the calorimeter wall construction. The thermal conductance and emittance of all the building components in those cross sections are input into the computer models to determine the heat flow through those sections. The total heat flow through the calorimeter walls is determined by area weighting the computed heat flow through the various cross sections.

The most accurate method of calculating the heat flows in and out of the calorimeter is by using three-dimensional computer analysis tools (i.e., HEATING 7, FIDAP). These computer programs allow detailed analysis of the convection and radiation environments encountered in a solar calorimeter. They are also very difficult and time consuming to use. Typically, these

computer programs require detailed three-dimensional computer drawings of the calorimeter wall construction, as well as the thermal conductance and surface heat transfer coefficients of all the building components.

### B3. Solar Calorimeter Calibration

The procedure given in this section outlines the steps required to verify the proper output of the calorimeter wall thermopile and to obtain the initial relationship between solar calorimeter wall heat flow, calorimeter loss and its transducer output. The latter series of calibration tests addresses the technique that will yield the heat flow relationship as a function of the transducer output including a zero offset, if present. In addition to the verification tests described in this Annex, the surround flanking loss calibration tests described in Annex C must be performed before testing actual specimens.

Note: Alternate procedures to evaluate the slope and offset of the calorimeter heat flow and flanking loss are acceptable, if documented and verified experimentally.

To perform both of these calibration tests, a calibration panel, as described in Annex F, must be instrumented and installed in the solar calorimeter. This calibration panel must fill the available dimensions of the test frame. The calorimeter wall calibration cannot be performed using a test specimen smaller than the solar calorimeter opening.

It is essential that the air velocities, power inputs and temperatures for the solar calorimeter and guard be held constant throughout each calibration test. By holding all the control parameters constant, the operator decreases the variability of the surface heat transfer coefficients on the calibration panel during the test.

### B4. Verifying Calorimeter Wall Transducer Null Offset

This procedure outlines a verification test required to confirm that the solar calorimeter wall transducer output is zero when there is no heat flow through the solar calorimeter walls. This method helps determine if the thermopile used to measure the temperature difference (and heat flow) across the calorimeter wall is wired properly. The construction of the calorimeter wall thermopile is described in Section 6.2.4.1.A and the proper operation of the thermopile shall be verified before additional calibration tests are performed.

Install a calibration panel, as specified in Section A6, in the thermal chamber. Do not start any fans, heaters or

instrumentation, which generates heat (i.e., hot wire anemometers) and shade the entire solar calorimeter from solar irradiation. Record the ambient air temperature, the temperatures of the air, absorber plate surfaces and surround panel in the calorimeter and the output from the calorimeter wall transducer (thermopile) for at least 24 hours after the calorimeter has reached steady state conditions with the surrounding ambient environment.

Once the solar calorimeter has reached steady state conditions with the ambient environment (this may take days to achieve); the surface and air temperatures in the solar calorimeter and guard (if present) should be close to each other. Therefore, the output from the calorimeter wall transducer should be close to zero. There may be a small cyclic output from the calorimeter wall transducer based on the diurnal fluctuation of temperature in the surrounding environment, but the average output over 24 hours should be zero. If the average output from the calorimeter wall transducer is not close to zero, then the wiring of the calorimeter wall thermopile should be checked and repaired, if necessary, before additional calibrations or calibration tests are performed.

#### B5. Calibration of Calorimeter Wall Transducer

This describes the process to determine the relationship between the output from the calorimeter wall transducer and the heat flow through the calorimeter walls when the temperature difference across the calibration panel may be close to zero. The environmental conditions generated during this test are likely to be different from actual test conditions. The results from these tests are used to establish the value of the coefficient that is multiplied by the output from the calorimeter wall transducer to determine the calorimeter wall loss. Any offset due to flanking loss or other anomalies is determined by the calibration tests described in Annex C.

Perform a minimum of three calibration tests with the calorimeter air temperature equal to  $\pm 5.0^{\circ}\text{C}$  ( $\pm 9.0^{\circ}\text{F}$ ) the ambient air temperature, but with the guarding temperature set to different values. The calorimeter air temperature shall be heated with the assistance of an auxiliary metered heater placed inside of the solar calorimeter. Otherwise the calorimeter controls shall be adjusted such that the fluid flow rate and temperatures are the same as during testing. The ambient temperature outside of the solar calorimeter shall not vary more than  $\pm 5.0^{\circ}\text{C}$  ( $\pm 9.0^{\circ}\text{F}$ ) and the heat exchanger fluid flow rate

shall not vary more than 1.0% over the duration of a test. In this configuration, negligible heat,  $Q$ , is flowing through the calibration panel and thereby, all the net heat into the calorimeter is lost (or gained) through the calorimeter walls.

Separate calibration tests need to be performed with the guarding temperature set at different values, but with the solar calorimeter air temperature held constant. The fans generating the airflow inside of the calorimeter shall also be set at constant speeds. It is recommended that at a minimum, one test be performed with the guarding temperature above the calorimeter air temperature, one test with the guarding temperature equal to the calorimeter air temperature and one test be performed with the guarding temperature below the calorimeter air temperature.

For the condition where the surface temperature difference across the calibration panel is close to zero, the flanking loss is also zero and the heat balance can be determined. By plotting the heat flow versus the output from the calorimeter wall thermocouple, the slope and the zero offset can be determined.

The measured calorimeter wall heat flow shall also be compared to the theoretical value calculated in Annex A2.2. If there is a significant discrepancy between the measured and calculated heat flow, conduct an investigation to identify the reason for this discrepancy. If all systems are operating satisfactorily, use the measured coefficients when performing the calibration tests specified in Annex C.

## **C. Surround Panel Flanking Loss Calibration**

### **C1. Calibration of Surround Panel Flanking Heat Flux**

When a test specimen is installed in the surround panel of a solar calorimeter, the heat flux through the aperture of the calorimeter is a combination of the heat flux through the test specimen, the heat flux through the surround panel and any flanking heat flux at the edge of the aperture where the surround panel is in contact with the solar calorimeter walls. This flanking heat flux is determined for each thickness of surround panel using the calibration test method specified in this Annex. The surround panel flanking heat flux tests shall be performed after the solar calorimeter wall heat flux transducer coefficient has been determined using the procedures outlined in the previous Annex.

For these calibration tests, the temperature of the outdoor face of a calibration panel, which is constructed of the same material

as the surround panel, is maintained at a higher temperature than the interior air temperature within the solar calorimeter. These tests are performed under full sunlight.

To perform flanking loss calibration, install and instrument a calibration panel of the appropriate thickness in the solar calorimeter as specified in Annex F. A separate calibration test is required for each surround panel thickness and assembly.

Track the sun to within  $\pm 5^\circ$  of normal to the source of solar irradiation. Record the data at a minimum of five-minute intervals until steady state conditions are reached per Section 7.4.

From this data the flanking loss can be calculated from the following equations:

$$Q_{fl} = Q_{fluid} - Q_{wall} - Q_{aux} - Q_{sp} \quad \text{Equation 11-3}$$

Where

- $Q_{fluid}$  = heat flux extracted from the liquid W (Btu/hr)
- $Q_{wall}$  = heat flux through the walls of the calorimeter W (Btu/hr)
- $Q_{aux}$  = energy contributed by auxiliary sources W (Btu/hr)
- $Q_{sp}$  = heat flux through the surround panel W (Btu/hr)
- $Q_{fl}$  = flanking heat flux of surround panel W (Btu/hr)

## D. Recommended Practice for Estimation of the Testing System Time Constant

### D1. General Considerations

The time required to conduct a solar calorimeter test is determined, in part, by the speed of response of the testing apparatus and the specimen's response to changes in its environment. One measure of this response to change is the time constant,  $\tau$ , of the system. The time constant of the system is the time required for the system to respond to within 37% (1/e) of its final value of response, usually energy flow, after a step change in forcing condition, usually upon sudden exposure to direct solar irradiation. As specified in Section 7.4, a minimum of five(5) time constants of consecutive, uniform data must be collected to determine if steady state conditions exist. Therefore, it is necessary that an accurate measure of the effective time constant,  $\tau_{eff}$ , of the operating solar calorimeter system be determined.

The operation of the solar calorimeter is an energy transfer problem. Therefore, it appears logical that the time controlling factors for the solar calorimeter test would include:

- C. the heating and cooling capacity for the apparatus.
- D. the air circulation patterns and velocity.
- E. the internal energy storage capacity of the test chamber equipment.
- F. the thermal diffusivity and resistance of the materials used to construct the chambers;
  - i. the effective solar absorptance of the absorber plate and calorimeter shell exposed to direct irradiation.
  - ii. the effectiveness of the absorber plate as a heat exchanger with the interior air.
  - iii. the specimen solar transmittance and absorptance.
- G. the specimen geometry.
- H. the specimen thermal diffusivity and resistance; and,
- I. the specimen energy storage capacity.

Also, any transient effects such as residual moisture change or the onset of convection within specimen might increase the time for stabilization for a test.

#### D2. Testing System Time Constant Evaluation

The solar calorimeter time response is controlled by either the apparatus design or the assembled properties of the specimen. For test purposes, if the apparatus time constant,  $\tau_{ap}$ , is greater than specimen time constant,  $\tau_s$ , the test will be controlled by the value of  $\tau_{ap}$ . If however,  $\tau_{ap} < \tau_s$ , then the specimen response will be the controlling factor in determining whether the test is complete. The apparatus time constant,  $\tau_{ap}$ , is determined by experimental measurement as described in Section D3 and the specimen time constant,  $\tau_s$ , is calculated as specified in Section D4. Note, however, that the two time constants may not be completely distinct and independent.

#### D3. Response of the Apparatus

The design of the apparatus must include consideration of the speed of response of the solar calorimeter to changing test conditions and the thermal lag caused by the heat capacity of the internal equipment. The speed of response of the apparatus or time constant,  $\tau_{ap}$ , is fixed by the design and, for a properly

designed system should, ideally, be less than the specimen time constant. Since the test apparatus is generally complex compared to the specimen and since it does not change with the specimen, the apparatus time constant,  $\tau_{ap}$ , can be determined by experimental means.

### D3.1 Experimental Determination of the Apparatus Time Constant

The time constant of the apparatus,  $\tau_{ap}$ , can be empirically determined by measuring the speed of response of the solar calorimeter with a specimen installed. As discussed in D1, for any experimental setup, the measured system time response is the sum of the time responses of the individual parts. Any attempt to measure, experimentally, the effective time constant,  $\tau_{eff}$ , will, in fact, be determining the combined response of the apparatus constant,  $\tau_{ap}$  and the specimen time constant,  $\tau_s$ . Therefore, if the time constant of the specimen can be forced to be significantly less than the time constant of the apparatus, then the apparatus time constant,  $\tau_{ap}$ , can be approximated using the simple experiment outlined in Annex D3.2.

Although it is impossible to create a specimen that has zero specific heat capacity and 100% solar transmittance, a specimen can be developed that has a low thermal resistance, low energy capacity and high solar transmittance. By examination of Equation 11-4, the specimen sample will have a lower time constant if the specific heat capacity (MsCs) is kept low, since  $A_s$  and  $h$  are fixed by the apparatus design. Therefore, to establish a good estimate of the minimum time constant for the apparatus, one must use a homogeneous, lightweight, high solar transmittance specimen, such as single pane clear glazing. This specimen design should produce the shortest test time constant for the testing system.

Therefore, the recommended practice is to measure the apparatus response to a step change in solar irradiation using a low mass, high solar transmittance specimen and then use those results to determine the shortest time constant of the system. The time constant of the system would then have to be increased if the time constant of the specimen is determined to be greater than the time constant of the apparatus.

### D3.2 Procedure for Experimental Time Constant Determination

The following experimental procedure is recommended for determining the time constant for a solar calorimeter.

Procure a specimen having the highest solar transmittance, the lightest weight and largest size that can be tested within the practical limits of the test apparatus.

Install and seal the specimen in the solar calorimeter, shade the entire solar calorimeter from direct sunlight and initiate test conditioning. Although the solar calorimeter is initially shaded from direct solar irradiation, the face of the solar calorimeter shall be pointed normal to the source of direct sunlight. For the initial test conditions, set the air and inlet fluid temperatures in the solar calorimeter to the typical set points (see ANSI/NFRC 200).

Set up the data acquisition system to record all test parameters at a minimum of one (1) minute intervals and begin recording data. Initiate the solar calorimeter tracking system to orient the solar calorimeter to within  $\pm 5^\circ$  of normal to the direct solar irradiation. The time constant tests shall be conducted when the levels of solar irradiation are fairly constant or decreasing; i.e., outdoor solar calorimeters need to be within one hour of solar noon or shortly thereafter.

Continue monitoring the test data until steady state is reached. For this determination use a minimum of 5 consecutive ten-minute time averages to establish steady state. (Refer to Section 7.4).

Once steady state conditions have been achieved; quickly remove the shading device from in front of the solar calorimeter so that the test specimen and solar calorimeter are in full direct sunlight. Allow the temperature control system to adjust the fluid temperatures to maintain the inside air temperature within the temperature limits used for testing. Record the time at which this change occurs and continue to monitor test data.

Continue monitoring the test data until steady state is reached (See Section 7.4). For this determination use a minimum of five consecutive ten-minute time averages to establish steady state.

Plot the time versus temperature and net sample energy flow rate (SHGC) for the period from shortly before the shading device is removed to the second time the solar calorimeter reaches steady state.

Determine the elapsed time from the time that the shading device is removed, in which the one-minute averages of temperatures and energy flow was 63.2% of the final value.

Determine the elapsed time from the time that the shading device is removed, in which the one-minute averages of temperatures and energy flow was 86.5% of the final value.

The maximum difference in times for Annex D3.2 is equal to the time constant for the test system,  $\tau_{\text{eff}}$ . The time constant of the solar calorimeter apparatus shall not be considered to be less than 10 minutes.

Note: For most circumstances, the time constant is independent of the magnitude of the incident solar irradiation or the energy flow of the system. The controlling factor for the time constant will be the energy capacity of the air and fluid systems and thermal resistance and solar absorbance of the solar calorimeter, absorber plate and specimen. Typically, solar calorimeters, which have suddenly been exposed to solar irradiation reach steady state condition faster than when the solar irradiation is suddenly shaded and the solar calorimeter must cool to reach a new steady state condition. In this circumstance, the rate of energy input by solar irradiation is much greater than the rate of energy flux that can be removed by the fluid flow and lost through the apparatus. The measured time constant of solar calorimeter system would be different depending on whether the solar calorimeter is suddenly exposed to direct sunlight or suddenly shaded during the time constant test. Since the heat flux in a solar calorimeter is primary driven by direct solar irradiation during test, the apparatus time constant should be determined while solar irradiation is incident on the test specimen. For this reason, it is best to perform time constant tests where the shading device is suddenly removed to expose the solar calorimeter to direct solar irradiation as opposed to suddenly shading a solar calorimeter that has previously reached steady state in full sunlight.

#### D4. Calculation of Specimen Time Constants

Since the value of the overall time constant,  $\tau_{\text{eff}}$ , determined in the previous section is for the low thermal resistance, low energy capacity, high solar transmittance specimen, it may be necessary to determine the time constants for other specimen constructions. Of course, one could repeat the experimental procedure of D3.2 for every specimen. However correct, this approach would be expensive.

An alternative is to calculate the time constant of the specimen based upon the simple formula shown in Equation 11-4. Fortunately, the time constant of a homogeneous system, such as a simple specimen, can be approximated by a first order equation, Equation 11-4.

$$\tau_S = \frac{M_S H C_S}{h' A_S} \quad \text{Equation 11-4}$$

Where

- $\tau_S$  = specimen effective time constant, hr
- $M_S$  = mass of the composite specimen, kg (lb)
- $H C_S$  = equivalent composite specific energy, W·hr/kg·K (Btu/hr·lb·°F)
- $A_S$  = energy transfer area, m<sup>2</sup> (ft<sup>2</sup>)
- $h'$  = the composite surface coefficient which includes an estimate of the internal energy flow resistance, W/m<sup>2</sup>K (Btu/hr·ft<sup>2</sup>·°F)

and:

$$\frac{1}{h'} = \frac{1}{h_s} + R \quad \text{Equation 11-5}$$

- $h_s$  = the surface coefficient, W/m<sup>2</sup>·K (Btu/hr·ft<sup>2</sup>·°F)
- $R$  = the estimated specimen resistance, m<sup>2</sup>·K/W (hr·ft<sup>2</sup>·°F/Btu)

This procedure still may be too complex for a typical window that has many structural members with significantly different energy flow rates. A further simplification for our purpose is to estimate the time constant for each of the simple energy flow paths and then combine them into an "averaged" time constant for the complex structure. Review of the ASHRAE Fundamentals volume and other resource books on transient energy transfer, shows that the common method for combining the energy transfer parameters for a complex structure is to add the system path effects together using a parallel path technique. Applying this principle to the calculation of the time constant yields the following:

$$\frac{A_S}{\tau_S} = \frac{A_1}{\tau_1} + \frac{A_2}{\tau_2} \dots + \frac{A_i}{\tau_{si}} \quad \text{Equation 11-6}$$

Where

- $A_S$  = overall specimen area, m<sup>2</sup> (ft<sup>2</sup>)
- $A_i$  = component energy path area, m<sup>2</sup>
- $\tau_S$  = specimen composite time constant, hr
- $\tau_{si}$  = specimen path component time constant, hr

#### D5. Overall Test Time Constant

The effective overall time constant is used to fix the time periods required for data acquisition and determination of final system stability. Above, methods of estimating the apparatus time constant,  $\tau_{ap}$  and the composite specimen time constant,  $\tau_S$ , for a solar calorimeter system. As outlined in D2, the remaining step is to choose the effective overall time constant that controls our process. This choice is made as follows:

- A. If  $\tau_S \gg \tau_{ap}$ , then use  $\tau_{eff} = \tau_S$ , or
- B. If  $\tau_{ap} \gg \tau_S$ , then use  $\tau_{eff} = \tau_{ap}$ , or
- C. If  $\tau_{ap} \approx \tau_S$ , then use the larger of  $\tau_{ap}$  or  $\tau_S$ .

For purpose of ease of calculation and data logging, the period of the scan time used for the test may be approximated by rounding up to the nearest simple fraction of five minute intervals. For example, if the time constant is determined to be 8.5 minutes, use 10 minutes. Or, if the time constant is 12.5 minutes, use 15 minutes. Remember this is a guide for testing and an exact determination is not required.

##### D5.1 Alternative Methods

Often a laboratory may be testing only one type of specimen. In these cases, a simplified method of determining the system time constant can be utilized. The following is an alternate method.

One alternate approach utilizes a high thermal resistance, high energy capacity, low solar transmittance system to determine the system time constant. By a line of analysis similar to that illustrated above, a frosted glass block wall, for example, would yield a very long specimen time constant. This time constant might significantly exceed the time constant of the apparatus. Therefore, this alternate method is to measure the time constant of the apparatus with the highest-mass

specimen installed and use that time constant for all specimens that are less massive. While this would eliminate the need to calculate the time constant of massive systems, it also would increase the time of testing required for less massive specimens.

### E. Calibration Transfer Standard Tests

Calibration Transfer Standards covering the range of test specimen sizes expected shall be tested at the using the procedures specified in Section 5 of this document and Annex A1 of ASTM C 1199 using the following environmental conditions:

- A. Interior Air Temperature = 24°C (75°F).
- B. Weather Side Air Temperature = 32.2°C (90°F) (see Figure 11-3).
- C. Surface Heat Transfer Coefficients and Tolerance as specified in Section 4.2 of NFRC 102.

**Figure 11-3**

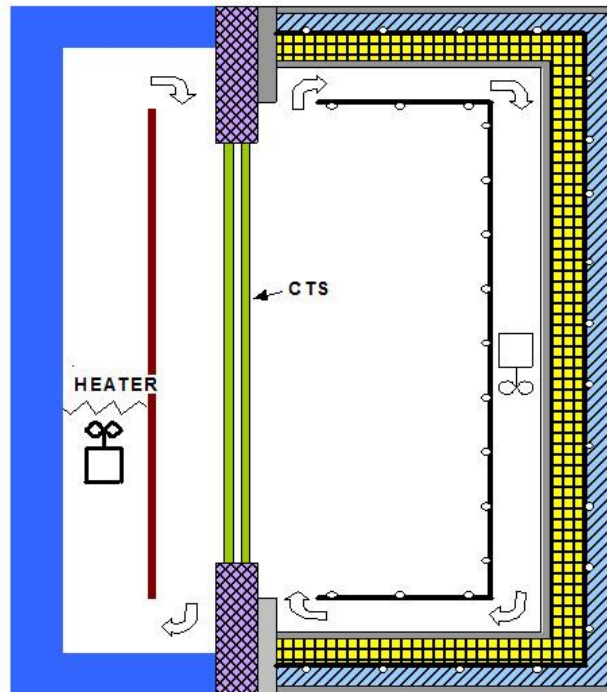

## F. Design and Construction of the Solar Calorimeter Calibration and Surround Panels

The procedures outlined in Annexes B and C outline the steps required to quantify the relationships for calorimeter wall loss and flanking loss. For the experimental analysis of these parameters, a calibration panel that fits the calorimeter opening is required. The surround panels required for measurement of specimens smaller than the opening of the solar calorimeter are identical in construction to the calibration panels. The exception is that the calibration panel is continuous, and the surround panel has a hole, at its center, large enough to hold the specimen. Since the construction, but not necessarily the thickness, is identical for both panels, this section presents instructions on the fabrication and instrumentation of both calibration and surround panels. For purposes of discussion below, the word “panel” will apply to both types.

The need to determine the panel heat flow,  $Q$ , accurately requires that the panel be designed to act as a heat flux transducer with a transducer output proportional to the temperature difference,  $\Delta t$ , which is in turn proportional to the total heat flow through it. This consideration is the basis for the specific recommendations, which follow.

### F1. Construction and Instrumentation of the Panels

The calibration panels must be constructed from a uniform thickness of a homogeneous and stable material of low thermal conductivity. Suitable materials are high-density glass fiber or polystyrene boards laminated together as necessary. The assembled panel must be non-hygroscopic to minimize changes in its thermal resistance with ambient humidity conditions. In addition, the assembled panel shall be opaque in the visible spectrum.

Surround panels may be fabricated by sandwiching layers of homogeneous insulation between layers of rigid materials such as plywood or plastic. Such surround panels, though non-homogeneous, are uniform in the direction perpendicular to the direction of heat flow and are characterized in the same manner as homogeneous panels. Surround panels must have adequate strength to support the weight of the specimens to be tested.

If the panel is assembled from multiple pieces of identical material, thickness and conductivity, then the joints between the pieces shall be sealed with tape or caulk that is at the same solar absorbance and emittance ( $\pm 0.1$ ) as the panel surface to which it is attached. Tape shall not be placed more than 50 mm (2.0 in) from the edge of the joint. If rigid insulation is used as

the core material, there is an opportunity to use a “tongue and groove” or a lapped joints to help minimize the air infiltration through the joint.

Note: A recommended surround panel core material is expanded polystyrene (bead board) having a density in excess of 20.0 kg/m<sup>3</sup> (1.2 lb/ft<sup>3</sup>), which has been aged unfaced in the laboratory for a minimum of 90 days. Polyisocyanurate or other fluorocarbon-expanded cellular foam insulations are not recommended as their thermal conductivity has been shown to significantly change over time. Suitable facing materials are approximately 3 mm (1/8 in) thick heat-resistant rigid ABS thermoplastic sheets with smooth or matte finish faces or a similar thickness hi-impact polystyrene plastic sheet. The surround panel may need to have some horizontal and vertical saw cuts made in the cold side facing material to minimize the effects of differential thermal expansion between the cold and hot side faces. The thin cuts should be covered with similar solar absorptance and emittance tape strips to provide a smooth surface to the weather and room side air streams.

## F2. Surround Panels

Surround panels are required for testing specimens smaller than the metering area. Their construction is similar to that of the calibration panels.

The surround panel aperture in which the specimen is installed should fit the specimen snugly. Cracks greater than 3 mm (1/8 in) width shall be filled with insulation and caulked or taped at the surround panel surfaces to prevent air leakage. It is desirable that the insulation used to fill cracks has the same conductivity and thickness as the surround panel assembly. The edge of the opening in the surround panel may be covered with nonreflecting tape to minimize surface damage of the exposed core insulation. Surround panels used for calibration testing must have the specimen aperture filled with the same material, thickness, thermal conductivity and assembly as the adjacent surround panel during the calibration tests. The joint between the perimeter surround panel and the panel filling the aperture shall be flush and sealed with tape or caulk as described above.

The thickness of the surround panel shall be at least the maximum thickness of the specimen and shall be in no circumstances less than 100 mm (4 in). Also, the maximum thickness of the surround panel shall be no more than 25 mm (1 in) greater than the maximum thickness of the test specimen.

That is, for test specimen maximum thickness less than or equal to 100 mm (4 in), the surround panel thickness shall be 100 mm (4 in). For test specimen maximum thickness greater than 100 mm (4 in), the surround panel thickness should be equal to the specimen thickness rounded to the next higher whole inch.

The restriction of surround panel thickness is to limit the flanking loss through the surround panel at the uncovered areas of its aperture. Other special instances, for example a window designed to be set a few inches outward from the plane of the inner surface of a wall, require special calibration of the surround panel. In this case, a calibration panel of known thermal conductance must be in the same position at the juncture with the surround panel aperture as the window.

Unless specifically required for test specimen mounting purposes (very high mass test specimens), no thermal anomalies (that is, thermal bridges like wood or metal) shall exist in the surround panel. It may be necessary, in some cases, to incorporate framing in the surround panel to support heavy specimens such as heavy-duty metal frame windows or masonry sections. Framing members must be kept away from the specimen aperture and away from the point of contact of the metering walls so as not to contribute excessively to lateral heat transfer at these locations. Such non-uniform surround panels must be characterized after the hole is cut using calibration blanks of the same thickness and thermal conductance as the insulated part of the surround panel. In those specific situations where the surround panel is not homogeneous, detailed drawings and description of the surround panel construction, along with the measured calibration results shall be included with the test report.

### F3. Instrumentation of Calibration and Surround Panels

The surface temperature sensors used to measure the temperature difference across the panel shall be permanently installed uniformly flush with or just under its surfaces. When thermocouples are used, they may be connected;

- A. as a differential thermopile for determination of the surround panel temperature difference; or,
- B. as individual thermocouples for exploring temperature distributions on the faces of the panel.

At a minimum density, there shall be five temperature sensors per square meter installed on each panel surface. The temperature sensors shall be placed in the center of equal sized

areas or their output shall be area weighted to determine the average temperature of the surround panel surface. At a minimum, there shall be four temperature sensors on each face of the surround panel. These four thermocouples shall be located at positions bisecting the sides of the rectangle. It is recommended that additional thermocouples be located at positions bisecting the four lines from the corners of the specimen aperture to the corresponding corners of the metering area. A suitable temperature sensor arrangement shall be chosen for non-uniform surround panels that provide representative average surface temperatures. This is particularly important when natural convection is used and air temperatures and film coefficients vary over the metering surface. If framing members are used, an area-weighted average of temperatures measured over the members and away from them is necessary. The panel, which acts as a heat flow meter, shall be calibrated so that the heat flow is known as a function of the average temperature difference (or thermopile output voltage) across it or as indicated by the permanently installed thermocouples.

Surround panels being used as calibration panels (i.e., the specimen aperture is filled with insulation) shall have a uniform layout of temperature sensors across the surround panel surface and the surface of the material filling the specimen aperture. It is sometimes more difficult to uniformly instrument the surround panel when the specimen aperture is filled with an actual specimen, which often has its own instrumentation scheme (i.e., as specified in ASTM E 1423).

To protect the panel and the permanently installed thermocouples, the surfaces must be impervious to air. In addition, the panel shall be opaque to visible light. A permanent coating or thin facing on each face of the panel is desirable. However, the coating or facing must be of low lateral conductance so that it does not contribute excessively to lateral heat transfer at the juncture with the specimen or at the boundary of the metering area. The solar absorbance and emittance of the panel surfaces shall be uniform and unchanged after calibration. In all cases, the emittance of the panel surfaces shall be high ( $\epsilon > 0.8$ ) and the solar absorbance be low ( $\alpha < 0.2$ ). The adhesive, caulk or tape used to mount the temperature sensor instrumentation shall have the same solar absorbance and emittance as the surrounding surface ( $\pm 0.1$ ). Surface temperature sensors and attachment techniques shall meet the requirements specified in Section 6.10 of ASTM C 1363. Surface temperatures shall be measured to  $\pm 1.0^\circ\text{C}$  ( $\pm 1.8^\circ\text{F}$ ).

It is probable that many specimens to be tested are inhomogeneous or non-uniform in construction for structural reasons and in consequence that the local thermal conductance differs considerably at different frontal areas of the element. The variations are inherent and the result of the test is an average conductance or transmittance value for the total construction, provided that the conductance variations at edges do not seriously impair the validity of using the surround panel as an adequate heat flow meter. This matter varies with each case and therefore must rest on the judgment and technical experience of those conducting the test measurement. A useful guiding principle is that nothing should be incorporated in or omitted from, a specimen being tested that would make it not representative of the assembly that would be found in actual installation in service. For example, if a metal window ordinarily is installed with inset wood framing, the test specimen should include just so much of the wood framing as is properly chargeable to it.

#### F4. Calibration of the Panel as a Heat flow Transducer

Characterization of any panel material, whether used for calibration, surround panel or as a transfer standard for windows testing (see ASTM C 1199) shall be made by means of thermal tests on a representative sample of the assembled panel, their individual components or tests on the entire panel. For this reason, it is required that the thermal resistance of a sample assembly of the calibration or surround panel be measured in a guarded hot plate (ASTM C 177) or a heat flow meter apparatus (ASTM C 518) at a minimum of three temperatures over the range of conditions at which the panel will be used (e.g., 2°C, 24°C and 43°C [35°F, 75°F and 110°F]).

The calibration should cover the range of mean temperatures at which the panel will be operated during the testing. At any one surround panel mean temperature, there should be little variation of  $Q_{sp}/\Delta t$  with  $\Delta t$ , but  $Q_{sp}/\Delta t$  may vary slightly with mean temperature due to the change of thermal conductivity to the surround panel material.

Note: Additional uncertainty may arise due to the possible influences of the specimen in causing two or three-dimensional heat flow at its boundary with the surround panel and thus affecting the surround panel heat flow in regions adjacent to the element. Surround panel heat flow, determined under a given set of conditions with a calibration standard in place, may change when the specimen is installed, even though the test conditions

remain unchanged. If the specimen is expected to have this influence, an attempt should be made to evaluate its impact on the desired accuracy of the test.

## **G. Tubular Daylighting Device (TDD) Installation and Testing**

### **G1. TDD Installation**

1. Install the TDD per the manufacturer's instructions. Include the manufacturer's installation instructions as an Appendix to the test report, and report any variations from these instructions.
2. Any flanges or mounting hardware in contact with the face of the surround panel shall be painted or covered with tape so that those components are within  $\pm 0.2$  of the solar absorbance of the surface of the surround panel. This added application of paint or tape on the test specimen shall be noted in the test report.
3. The TDD shall be installed in a 762 mm (30.0 in) thick surround panel with an aperture of sufficient size to accommodate the TDD. The Flanking Loss of the surround panel shall be determined as specified in Annex C at the same solar incident angle as the test is performed.
4. The TDD shall have a shaft diameter as close as possible to those found in Table 4.3 of ANSI/NFRC 100 or if the product is not round, the cross-sectional area will be as close as possible to the cross-sectional area of a tube with the diameter in Table 4.3 of ANSI/NFRC 100. The size will also meet the requirements of Section 4.6.1 of ANSI/NFRC 100 and the shaft length shall be 762mm (30.0 in).
5. The TDD shall be sealed on both the interior and exterior faces of the surround panel to minimize air leakage.
6. If the dome is not symmetrical, install the TDD in an orientation as specified by the manufacturer, and include a description of that orientation in the test report.

### **G2. TDD Testing**

1. Tubular Daylighting Devices shall be tested at a Solar-Surface Altitude of  $30^\circ \pm 2^\circ$  and a Solar-Surface Azimuth of  $0^\circ \pm 2^\circ$ .

2. Tubular Daylighting Devices shall be tested with the solar calorimeter at a tilt angle of 60° or greater from a vertical orientation (i.e., 30° or less from horizontal).
3. The Thermal Opening Area, as defined in Section 3.1, shall be used in lieu of the variable  $A_s$  in Equation 8-2 to calculate the SHGC.

---

---

## REFERENCES

- 1) Arasthe, D.K, Fnlayson, E., Mitchell, R., Huizenga, C., & Curcija, D., "THERM 2.1 – A PC Program for Analyzing Two-Dimensional Heat Transfer Through Building Products"; LBNL, 1999.
- 2) Arasthe, D.K., Finlayson, E.U. and Hizenga, C, "WINDOW 4.1: A PC Program for Analyzing Window Thermal Performance"; LBNL 1994.
- 3) Enermodal Engineering, Ltd. "FRAME – A computer Program to Evaluate the Thermal Performance of Window Frame Systems"; Version 3.0, Enermodal Engineering, Ltd.
- 4) Langmuir, I., Adams E. Q. and Meikle F. S., "Flow of Heat Through Furnace Walls" *Transactions American Electrochemical Society*, Vol. 24, 1913, pp. 53-84.
- 5) McCluney, R. "Sensitivity of Optical Properties and Solar Gain of Spectrally Selective Glazing Systems to Changes in Solar Spectrum," *Proceedings of the 22<sup>nd</sup> Annual Solar Conference*, Washington, DC: American Solar Energy Society, 1995.
- 6) McCluney, R., "Sensitivity of Fenestration Solar Gain to Source Spectrum and Angle of Incidence," *ASHRAE Transactions* 10 (June 1996).
- 7) Schenck, H., *Theory of Engineering Experimentation*, McGraw Hill, New York, N.Y., Third Edition, 1979, Chapter 3, p. 53.
- 8) Wilcox, S. and Al-Abbadi, N., "Using Irradiance and Temperature to Determine the Need for Radiometer Calibrations," *Forum 2001: Proceedings of the ASES Annual Conference*, Washington, DC, April 2001.
- 9) *NFRC 701.05: NFRC 201 Solar Calorimeter Test Reporting Requirements*. National Fenestration Rating Council: Greenbelt, MD; 2017. [www.nfrc.org](http://www.nfrc.org).

---

---

**INDEX**

<b>A</b>	
Absorptance	16, 17, 28, 31, 36, 39, 45, 46, 55, 60, 62, 68, 76
Accreditation Program	ii
<b>Air Leakage</b>	i, ii, 12, 23, 28, 45, 76, 80
Air Mass	22, 48
Ambient Temperature	41, 48
Angle of Incidence	16, 42, 81
Angular Selectivity	21
Area	11, 15, 16, 17, 18, 25, 26, 29, 31, 36, 45, 46, 51, 52, 54, 58, 61, 63, 72, 76, 77, 78, 80
Center-of-glazing	12
Attachment	25, 36, 46, 60, 78
Azimuth	40, 41, 42, 80
<b>B</b>	
Baffle	19
Bead	26, 37, 60, 75
<b>C</b>	
Calibration Transfer Standard	15, 17, 19, 22, 29, 74
CAP	ii
CAR	ii
Center-of-Glazing	44, 45
Certified Products Directory	ii
Compliance and Monitoring Program	ii
Condensation Resistance	i
CR	ii
Control Boundary	15, 25, 31, 32, 50
Curtain Wall	12
<b>D</b>	
Diffuse	11, 15, 20, 21, 22, 35, 43
<b>F</b>	
Fenestration	11, 12, 13, 15, 16, 19, 20, 22, 23, 24, 32, 33, 42, 44, 45, 46, 47, 58, 81
Attachment	45
System	11, 12, 16, 19, 20, 22, 23, 42, 46
Film	33, 78
Finish	76
Frame	22, 23, 30, 40, 44, 46, 57, 64, 77, 81
<b>G</b>	
Glass	17, 19, 30, 31, 44, 73, 75
Glazing	11, 13, 15, 21, 23, 24, 29, 30, 31, 44, 45, 46, 47, 69, 81
Glazing System	11, 21, 29, 47, 81
Greenhouse/Garden Window	23
<b>H</b>	
Heat Flux	12, 18, 28, 29, 33, 34, 37, 43, 50, 51, 62, 66, 67, 71, 75
Homogeneous Material	62
Hybrid Tubular Daylighting Device	20
<b>I</b>	
IA	v
Independent Certification and Inspection Agency	IA i, ii
Irradiance	15, 20, 27, 41, 43, 47, 48, 49, 81
<b>L</b>	
Laboratory Accreditation Program	i, ii
LAP	i, ii
<b>M</b>	
Model Size	30
<b>N</b>	
NFRC Label	ii
<b>O</b>	
Opaque	11, 75, 78
<b>P</b>	
Product Certification Program	i, ii
PCP	i, ii
Profile Angle	15, 18, 56, 57
<b>Pyranometer</b>	15, 24, 41, 42, 43, 56
<b>R</b>	
Radiant Flux	15, 41, 48
Radiation	11, 16, 20, 21, 22, 28, 32, 33, 34, 35, 41, 63
Radiometer	15, 41, 81
Rating	13, 20, 22, 47, 81
Rating System	i, ii, 47
Reflectance	19

## S

Sash.....	22, 46
Solar.....	11, 12, 13, 15, 16, 17, 18, 19, 20, 21, 22, 23, 24, 25, 26, 27, 28, 29, 30, 31, 32, 33, 34, 35, 36, 37, 38, 39, 40, 41, 42, 43, 44, 45, 46, 47, 48, 49, 50, 51, 52, 53, 54, 55, 56, 57, 58, 59, 60, 62, 63, 64, 65, 66, 67, 68, 69, 70, 71, 73, 74, 75, 76, 78, 80, 81
Solar Calorimeter .....	11, 15, 16, 18, 20, 21, 22, 24, 25, 26, 27, 28, 29, 30, 33, 34, 35, 36, 37, 38, 39, 40, 43, 44, 45, 46, 47, 48, 49, 50, 51, 52, 53, 54, 56, 57, 58, 59, 62, 63, 64, 65, 66, 67, 68, 69, 70, 71, 73, 74, 75, 80
Solar Heat Gain.....	11, 13, 16, 19, 20, 21, 22, 24, 31, 45, 49, 51, 56, 57
Solar Heat Gain Coefficient .....	11, 13, 16, 19, 20, 22, 23, 24, 31, 32, 44, 45, 47, 49, 50, 51, 53, 56, 57, 58, 70, 80
Solar Irradiance .....	15, 17, 27, 41, 42, 47, 49, 50
Average.....	15
Global .....	15
Solar Radiation.....	11, 13, 15, 16, 20, 21, 22, 30, 33, 34, 35, 36, 39, 41, 42, 46
Solar-Air Heat Transfer Coefficient Meter .....	15, 17, 30, 39, 43, 49, 55, 58, 59, 62
Spacer .....	44
Spectral.....	16, 20, 21, 22, 30, 33, 36, 41, 47, 48
Specular .....	13
Steady-State Conditions.....	29, 49, 56
Surface Heat Transfer Coefficient ..	15, 17, 19, 20, 22, 29, 33, 43, 49, 53, 54, 55, 58, 63, 64, 74, 78

Surround Panel.....	15, 16, 17, 18, 19, 23, 25, 26, 27, 28, 29, 30, 31, 32, 34, 35, 36, 39, 44, 45, 48, 49, 50, 52, 57, 62, 64, 66, 67, 74, 75, 76, 77, 78, 79, 80
---------------------	--

## T

Temporary Label .....	v
Thermal Bridge.....	23, 58, 77
Thermal Conductance.....	15, 17, 37, 52, 63, 77, 78
Thermal Conductivity .....	61, 63, 75, 76, 79
<i>Thermal Resistance</i> .....	19, 23, 69, 71, 73, 75, 79
Thermal Transmittance.....	12, 18, 19, 23, 43, 47, 51, 53, 54, 55, 56
Tilt Angle.....	21, 22, 24, 30, 42, 80
Time Constant.....	27, 29, 42, 50, 67, 68, 69, 70, 71, 72, 73
Translucent.....	11
Transmittance .....	16, 19, 23, 30, 33, 53, 54, 55, 68, 69, 71, 73, 78
<i>Transparent</i> .....	17, 45, 46
Tubular Daylighting Device.....	11, 20, 44, 80

## V

Visible Transmittance.....	i, 13
VT <sub>i</sub> , ii	

## W

Window .....	72, 76, 79, 81
Roof.....	23
Wood.....	30, 77, 79