



NATIONWIDE EVALUATION OF X-RAY TRENDS (NEXT)

SUMMARY OF 2003 FLUOROSCOPY SURVEY

September 2009

Published by
Conference of Radiation Control Program Directors, Inc.
www.crcpd.org

[Inside Front Cover-Intentionally Blank]

NATIONWIDE EVALUATION OF X-RAY TRENDS (NEXT)

SUMMARY OF THE 2003 FLUOROSCOPY SURVEY

Prepared by Richard Kaczmarek

Division of Mammography Quality and Radiation Programs
Office of Communication Education and Radiation Programs
Center for Devices and Radiological Health
Food and Drug Administration
Rockville, MD 20850

In Association with

Conference of Radiation Control Program Directors' Committee on NEXT

Members

Warren Freier, (ND), Current Chairperson
Mary Ann Spohrer (IL), Chairperson in 2003
Aaron Gantt (SC)
Bruce Matkovich (MI)
Jay Nakasone (HI)
John Neal (NE)

Resource Individuals

Mike Leal (ORA)
Jan Martensen (ACA)
Tom Ruckdeschel (ACR)
David Spelic (CDRH)
Keith Strauss (AAPM)

Advisors

George Eicholtz (ID)
Jennifer Elee (LA)
Karen Farris (MA)
Jack Ferruolo (RI)
Beverly Hall (NC)
Gary Kaus (SD)
Joji Ortego (CA)
Margie Wanchick (OH)
Diana Wozniak (CT)

With financial assistance from the
American College of Radiology

September 2009

Conference of Radiation Control Program Directors, Inc.
1030 Burlington Lane, Suite 4B
Frankfort, KY 40601
www.crcpd.org

This publication was supported in part by grant number FD-U-000005 from the Food and Drug Administration.

The information contained in this document is for guidance. The implementation and use of the information and recommendations contained in this document are at the discretion of the user. The implications from the use of this document are solely the responsibility of the user.

This document has been developed by a working group of the Conference of Radiation Control Program Directors, Inc. (CRCPD) and accepted by the Board of Directors for publication. The contents contained herein, however, may not necessarily represent the views of the entire membership of the CRCPD or any federal agency supporting the work contained in this document. The mention of commercial products, their sources, or their use in connection with material reported herein is not to be construed as either an actual or implied endorsement of such products by the CRCPD or any federal agency.

FOREWORD

The Conference of Radiation Control Program Directors, Inc. (CRCPD) is an organization made up of the radiation control programs in each of the 50 states, the District of Columbia, and Puerto Rico, and of individuals, regardless of employer affiliation, with an interest in radiation protection. The primary purpose and goal of CRCPD is to assist its members in their efforts to protect the public, radiation worker, and patient from unnecessary radiation exposure. CRCPD also provides a forum for centralized communication on radiation protection matters between the states and the federal government, and between the individual states.

One method of providing assistance to the states, as well as to other interested parties, is through technical and administrative publications. Most technical publications of CRCPD are written by various committees, task forces or special working groups. Most administrative publications are written by staff of the Office of Executive Director (OED).

CRCPD's mission is "to promote consistency in addressing and resolving radiation protection issues, to encourage high standards of quality in radiation protection programs, and to provide leadership in radiation safety and education."

This particular publication, *Nationwide Evaluation of X-ray Trends (NEXT) Summary of the 2003 Fluoroscopy Survey*, is the release of this data for informational use. No conclusions are included; these are left for in-depth analysis and publications in technical journals.



Adela Salame-Alfie, Ph.D., Chairperson
Conference of Radiation Control
Program Directors, Inc.

PREFACE

The Nationwide Evaluation of X-ray Trends (NEXT) is a national program conducted to characterize the radiation doses patients receive and to document the state of the practice of diagnostic radiology. This program is conducted jointly by the Conference of Radiation Control Program Directors, Inc. (CRCPD), an association of state and local radiation control agencies, and the Food and Drug Administration's (FDA) Center for Devices and Radiological Health (CDRH), with financial assistance from the American College of Radiology (ACR).

Every one-to-two years the NEXT survey program selects a particular radiological examination for study. Facilities are randomly selected for participation, and the surveys are performed by personnel from the radiation control agencies of participating states. The procedures used by surveyors for the collection of data are contained in a written protocol that is included in this publication.

For the 2003 fluoroscopy survey, a random sample was selected from the national population of clinical facilities performing upper gastrointestinal fluoroscopy. The surveyed sample size was 186 facilities, out of a selected sample size of approximately 350. Of these, 151 were classified as hospitals and 35 as non-hospital facilities. The complete data set has been entered into a computer data base, and can be made available to anyone interested in examining it or doing further analysis.

Data are presented in graphical and tabular form, where the bar and pie charts are developed from the data tables. The summary of the statistical analyses includes maximum and minimum sample values, and estimators for the median, mean, standard deviation, and quartile bounds.

ACKNOWLEDGMENTS

We thank the state radiation control personnel from the following states who contributed their time and efforts to make this survey happen:

Arkansas	Maine	Pennsylvania
Arizona	Michigan	Rhode Island
California	Mississippi	South Carolina
Idaho	Nebraska	Texas
Illinois	New Jersey	Utah

Iowa	North Carolina	Virginia
Kentucky	North Dakota	Washington
Louisiana	Ohio	Wisconsin
Massachusetts	Oregon	

This survey would not have been possible without their participation.

Richard Kaczmarek

Richard Kaczmarek
 Food and Drug Administration
 Division of Mammography Quality and Radiation Programs

Warren Freier, R.T.

Warren Freier, Current Chairperson
 Committee on Nationwide Evaluation
 of X-ray Trends

Mary Ann Spohrer

Mary Ann Spohrer, Chairperson in 2003
 Committee on Nationwide Evaluation
 of X-ray Trends

ABSTRACT

Kaczmarek, Richard, CRCPD Committee on Nationwide Evaluation of X-ray Trends, *Nationwide Evaluation of X-ray Trends (NEXT) Summary of the 2003 Fluoroscopy Survey*, CRCPD Publication #E-09-5 (September 2009) (100 pp).

This document presents 2003 fluoroscopy survey data. The tables and graphs are a summary of the data collected as part of the Nationwide Evaluation of X-ray Trends program. No conclusions are included.

The protocol used for the collection of the data is provided as an appendix.

CONTENTS

Foreword.....	iii
Preface.....	v
Acknowledgments	v
Abstract.....	vii

PART ONE

EQUIPMENT INFORMATION AND OPERATING PARAMETERS FOR ALL FLUOROSCOPY UNITS SURVEYED

Introduction	1
Weekly workload for unit surveyed.....	2
Facility weekly workload	2
Age of fluoroscopic systems.....	3
Type of fluoroscopic equipment	3
Fluoroscopy recording modes available.....	3
Contrast method used during exams.....	3
Image intensifier size distribution.....	4
Fluoroscopy half-value layer.....	4
Fluoroscopic kV observed when using NEXT fluoroscopy phantom	5
Fluoroscopic kV observed with NEXT fluoroscopy phantom and copper filter ...	6
Fluoroscopic mA observed with NEXT fluoroscopy phantom	7
Fluoroscopic mA observed with NEXT fluoroscopy phantom and copper filter ..	8
Image quality test tool hole scores	9
Image quality test tool mesh scores	10
Optical density of hardcopy images	11
Measured darkroom fog	11
Processing speed index (STEP)	12

PART TWO

DOSE/EXPOSURE RESULTS FOR FLUOROSCOPY UNITS WITH UNDER TABLE TUBES

Introduction.....	13
Fluoroscopic dose/exposure rate 1 cm above table top for hospitals/non-hospitals.....	14

Fluoroscopic dose/exposure rate 1 cm above table top for digital vs. film recording modes	15
Fluoroscopic dose/exposure rate 1 cm above table top with copper filter for hospitals/non-hospitals.....	16
Fluoroscopic dose/exposure rate 1 cm above table top with copper filter for digital vs. film recording modes.....	17
Maximum fluoroscopic dose/exposure rate 1 cm above table top with lead sheet for hospitals/non-hospitals	18
Maximum fluoroscopic dose/exposure rate 1 cm above table top with lead sheet for digital vs. film recording modes	19
Dose/exposure at table top for a single radiographic image for hospitals/non-hospitals.....	20
Dose/exposure at table top for a single radiographic image for digital vs. film recording modes	21
Dose/exposure at table top for a single radiographic image with copper filter for hospitals/non-hospitals.....	22
Dose/exposure at table top for a single radiographic image with copper filter for digital vs. film recording mode	23
Total number of radiographic imaging exposures	24
Total dose/exposure at table top from all radiographic images.....	24

PART THREE

DOSE/EXPOSURE RESULTS FOR FLUOROSCOPY UNITS WITH OVER TABLE TUBES

Introduction	25
Fluoroscopic dose/exposure rate 30 cm above table top	26
Fluoroscopic dose/exposure rate 30 cm above table top with copper filter	27
Maximum fluoroscopic dose/exposure rate 30 cm above table top with lead sheet	28
Dose/exposure rate 30 cm above table top for a single radiographic image ...	29
Dose/exposure rate 30 cm above table top for a single radiographic image with copper filter	30
Total number of recording mode exposures	31
Total dose/exposure 30 cm above table top from all radiographic images	31

PART FOUR:
RESULTS OF FACILITY PRACTICE SURVEY

Introduction.....	32
Facility Staffing	
Number of x-ray technologists on staff.....	33
Number of radiologists on staff	33
Number of medical physicists on staff.....	34
Number of contract medical physicists employed	34
Radiographic Exams	
Estimated number of general radiographic exams	35
Estimated number of portable radiographic exams.....	35
Estimated number of general purpose fluoroscopic exams	36
Estimated number of special purpose fluoroscopic exams	36
Estimated number of screening mammographic exams	37
Estimated number of diagnostic mammographic exams	37
Estimated number of magnetic resonance imaging exams.....	38
Estimated number of computed tomography exams	38
Estimated number of ultrasonography exams	39
Estimated number of dental exams.....	39
Estimated number of mobile radiographic exams	40
Estimated number of nuclear medicine exams	40
Estimated number of bone density exams	41
X-Ray Equipment	
Current and projected type of fluoroscopic/radiographic systems in use at facility for performing upper G.I. exams	42
Number of general purpose radiographic/fluoroscopic systems in use at facility	42
Number of dedicated angiographic units in use at facility.....	43
Number of dedicated electrophysiology units in use at facility	43
Number of dedicated interventional radiology units in use at facility ...	44
Number of mobile c-arm units in use at facility.....	44
Physics Quality Assurance Testing	
Frequency of physics testing for x-ray units performing upper G.I. fluoroscopy that were surveyed as part of the NEXT study.....	45
Testing typically performed as part of the physics survey	45

Questions Regarding Interventional Procedures	
Does the facility have a user credentialing program?	46
Is the user credentialing program provided in-house or under contract?	46
Does the facility have a patient dose monitoring program in place?	46
Brief description of the facility patient dose monitoring program	46
If the JCAHO should incorporate fluoroscopically induced skin injuries into its Sentinel Event program, does the facility have a policy and procedure in place to conduct a causal analysis of this type of event?	48
Does the patient consent form used by the facility for interventional procedures address radiation exposure and potential skin injuries?	48
Is it standard procedure to question patients regarding their history of medical imaging exposure?	48
Does the facility conduct any follow up on patients relating to possible radiation induced injuries which could result from fluoroscopic procedures?	49
What image intensifier field size is most typically used when fluoroscopy is employed during interventional procedures?	49
Appendix. Protocol for the 2003 Fluoroscopy Survey	50

PART ONE

Equipment Information and Operating Parameters for all Fluoroscopy Units Surveyed

The information in this section is presented in a manner that contrasts the findings for facilities designated as hospitals with those of non-hospital facilities. The factor determining how to classify a facility was the surveyor's response to the question of whether beds are provided for overnight stay. The count of surveyed facilities was 151 hospitals and 35 non-hospitals. However, some surveys were incomplete, and this is reflected in the cumulative frequency columns of the data tables. In most cases, missing or indeterminate results are ignored; however in some instances the percentage of the sample that is unknown is stated.

The information reported in this section was mostly obtained by direct measurement and observation; however some data, such as workload estimates, was provided by staff members at the surveyed facilities.

The image quality test object that was imaged and scored consists of a series of eight copper mesh screens (20 to 120 wires/inch), and a 6.1 mm thick aluminum disk that has eight holes (7.94 mm diameter each) bored to different depths (the test object is fully described in the protocol for performing this survey).

Abbreviations used in statistics tables:

Q1 = First Quartile
Q3 = Third Quartile
Freq = Frequency

Std Dev = Standard Deviation
Cum Freq = Cumulative Frequency

Weekly workload of upper gastrointestinal (G.I.) exams for unit surveyed
for hospitals (H)/non-hospitals (N/H)

Number of Procedures	Frequency		Percent		Cum Freq	
	H	N/H	H	N/H	H	N/H
< 5	33	9	21.9	25.7	33	9
5-10	57	13	37.7	37.1	90	22
11-20	40	10	26.5	28.5	130	32
21-30	14	3	9.3	8.6	144	35
>30	7	0	4.6	0	151	35

Statistics for hospital (H)/non-hospital (N/H)

Minimum		Q1		Median		Q3		Maximum		Mean		Std Dev	
H	N/H	H	N/H	H	N/H	H	N/H	H	N/H	H	N/H	H	N/H
1	1	5	4.5	10	10	15.5	15	200	30	13	10.8	17.7	7.4

Combined statistics for all facilities surveyed

Q1	Median	Q3	Mean	Std Dev
5	10	15	12.6	16.3

Weekly total facility workload of upper G.I. exams
for hospitals (H)/non-hospitals (N/H)

Number of Procedures	Frequency		Percent		Cum Freq	
	H	N/H	H	N/H	H	N/H
< 5	24	8	15.9	22.9	24	8
5-10	41	12	27.2	34.3	55	20
11-20	41	11	27.2	31.4	96	31
21-30	23	3	15.2	8.6	119	34
> 30	22	1	14.6	2.9	151	35

Statistics for hospital (H)/non-hospital (N/H)

Minimum		Q1		Median		Q3		Maximum		Mean		Std Dev	
H	N/H	H	N/H	H	N/H	H	N/H	H	N/H	H	N/H	H	N/H
1	1	7.5	5.5	15	10	25	19	325	60	20.2	13.1	30.4	11.2

Combined statistics for all facilities surveyed

Q1	Median	Q3	Mean	Std Dev
6.3	12	22	18.8	27.9

Age of fluoroscopy systems

Year of Manufacture	Hospitals		Non-Hospitals	
	Number	Percent	Number	Percent
Before 1990	20	13.2	6	17.1
1990-99	90	59.6	22	62.9
2000 or later	35	23.2	7	20
Unknown	6	4.0	0	0

Type of fluoroscopy equipment

Equipment Type	Hospitals		Non-Hospitals	
	Number	Percent	Number	Percent
Non-image intensified	1	0.7	0	0
Image intensified w/o video monitor	1	0.7	2	5.7
Image intensified under table w/ video monitor	127	86.4	30	85.7
Image intensified over table w/ video monitor	18	12.2	3	8.6

Fluoroscopic recording modes available

Recording Mode	Hospitals		Non-Hospitals	
	Number	Percent	Number	Percent
Spot Film	49	32.4	18	51.4
Digital	101	66.9	17	48.6
Unknown	1	0.7	0	0

Type of contrast technique used in upper G.I. exam

Type of Contrast	Hospitals		Non-Hospitals	
	Number	Percent	Number	Percent
Always single	18	11.9	1	2.9
Always double	67	44.4	26	76.5
Both/mostly barium	17	11.3	1	2.9
Both/mostly air	26	17.2	2	5.9
Both equally	23	15.2	4	11.8

Image intensifier size distribution

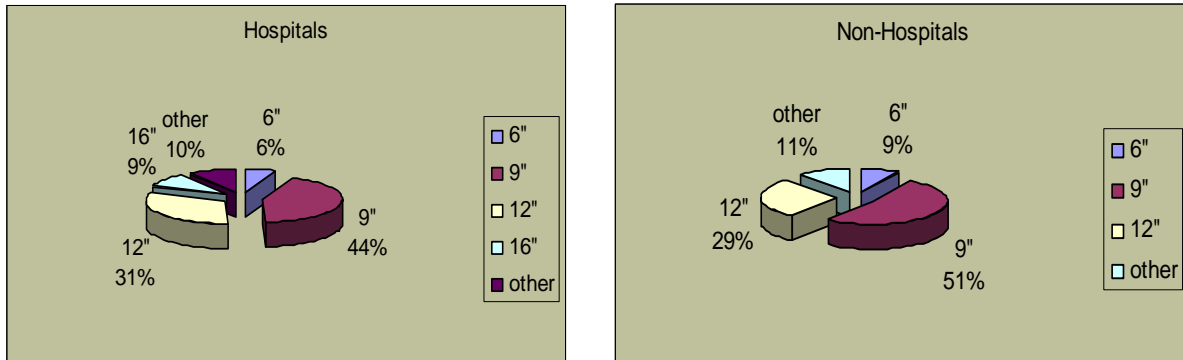

Fluoroscopy half-value layer (HVL)

HVL (mm Al)	Frequency		Percent		Cum Freq	
	H	N/H	H	N/H	H	N/H
< 3.0	7	1	4.9	2.9	7	1
3.0 - 3.99	34	11	23.8	31.4	41	12
4.0 - 4.99	49	15	34.3	42.8	90	27
5.0 - 5.99	40	7	27.9	20	130	34
6.0 - 6.99	10	1	7	2.9	140	35
> 6.99	3	0	2.1	0	143	35

Statistics for hospital (H)/non-hospital (N/H)

Minimum		Q1		Median		Q3		Maximum		Mean		Std Dev	
H	N/H	H	N/H	H	N/H	H	N/H	H	N/H	H	N/H	H	N/H
2.1	2.9	3.9	3.8	4.6	4.4	5.3	4.8	8.0	6.5	4.6	4.3	1.0	0.8

Combined statistics for all facilities surveyed

Q1	Median	Q3	Mean	Std Dev
3.9	4.5	5.2	4.6	0.99

Fluoroscopic kVp observed when using the NEXT fluoroscopy phantom

Energy (kV)	Frequency		Percent		Cum Freq	
	H	N/H	H	N/H	H	N/H
< 80	19	3	12.8	8.6	19	3
80-99	81	20	54.7	57.1	100	23
100-115	27	10	18.2	28.6	127	33
> 115	21	2	14.2	5.7	148	35

Statistics for hospital (H)/non-hospital (N/H)

Minimum		Q1		Median		Q3		Max		Mean		Std Dev	
H	N/H	H	N/H	H	N/H	H	N/H	H	N/H	H	N/H	H	N/H
71	74	85	85	92	88	105	100	125	120	95	93	14.3	12.6

Combined statistics for all facilities surveyed

Q1	Median	Q3	Mean	Std Dev
85	92	104	95	14.0

Distribution of fluoroscopic kVp observed using NEXT fluoroscopy phantom

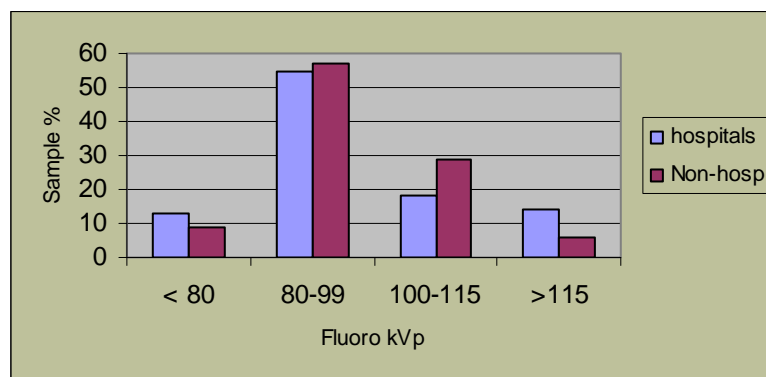

Fluoroscopic kVp observed
when using the NEXT fluoroscopy phantom with copper filter

Energy (kV)	Frequency		Percent		Cum Freq	
	H	N/H	H	N/H	H	N/H
<80	2	0	1.4	0	2	0
80-99	14	6	9.5	17.6	16	6
100-115	55	10	37.2	29.4	71	16
>115	77	18	52	55.9	148	34

Statistics for hospital (H)/non-hospital (N/H)

Minimum		Q1		Median		Q3		Max		Mean		Std Dev	
H	N/H	H	N/H	H	N/H	H	N/H	H	N/H	H	N/H	H	N/H
75	90	110	105	118	118	120	120	125	125	113	112	9.9	10.7

(Note: A 1.6 mm copper filter was added to the phantom to simulate a nominal 2 mm barium sulfate suspension.)

Fluoroscopic kVp observed using NEXT fluoroscopy phantom
with copper filter

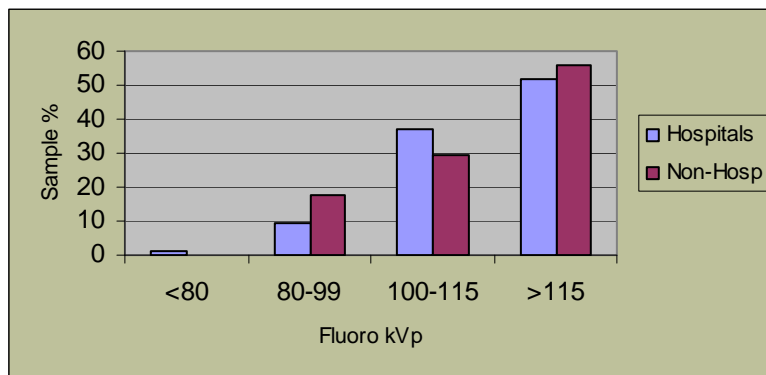

Fluoroscopic mA observed using NEXT fluoroscopy phantom

Tube Current (mA)	Frequency		Percent		Cum Freq	
	H	N/H	H	N/H	H	N/H
<1.0	8	2	5.4	5.9	8	2
1.0-1.9	40	15	27.2	44.1	48	17
2.0-2.9	77	11	52.4	32.3	125	28
3.0 or >	22	6	15	17.6	147	34

Statistics for hospital (H)/non-hospital (N/H)

Minimum		Q1		Median		Q3		Maximum		Mean		Std Dev	
H	N/H	H	N/H	H	N/H	H	N/H	H	N/H	H	N/H	H	N/H
0.3	0.5	1.8	1.2	2.2	1.9	2.7	2.5	9.1	5.0	2.3	2.0	1.2	0.9

Combined statistics for all facilities surveyed

Q1	Median	Q3	Mean	Std Dev
1.6	2.1	2.7	2.3	1.1

Fluoroscopic mA observed using NEXT fluoroscopy phantom

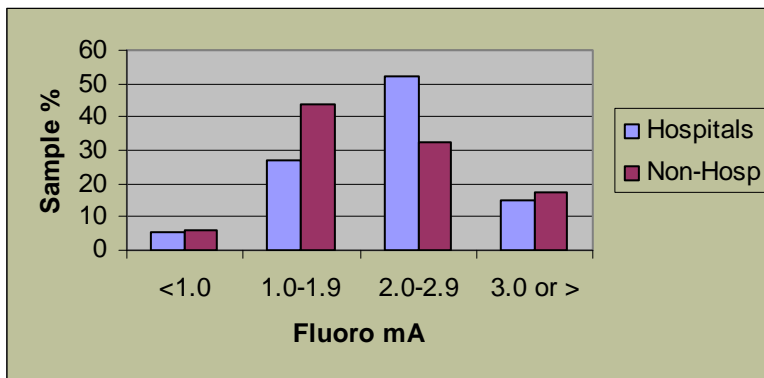

Fluoroscopy mA observed using NEXT fluoroscopy phantom with copper filter

Tube Current (mA)	Frequency		Percent		Cum Freq	
	H	N/H	H	N/H	H	N/H
<1.0	2	0	1.4	0	2	0
1.0-1.9	19	6	12.9	18.2	19	6
2.0-2.9	61	17	41.5	51.5	61	23
3.0 or >	65	10	44.2	30.3	147	33

Statistics for hospital (H)/non-hospital (N/H)

Minimum		Q1		Median		Q3		Maximum		Mean		Std Dev	
H	N/H	H	N/H	H	N/H	H	N/H	H	N/H	H	N/H	H	N/H
0.4	1.2	2.0	2.0	2.8	2.2	3.1	3.0	7.2	5.2	2.8	2.6	1.0	1.0

(Note: A 1.6 mm copper filter was added to the phantom to simulate a nominal 2 mm barium sulfate suspension.)

Combined statistics for all facilities surveyed

Q1	Median	Q3	Mean	Std Dev
2	2.7	3.1	2.7	1.03

Fluoroscopic mA observed using NEXT fluoroscopy phantom with copper filter

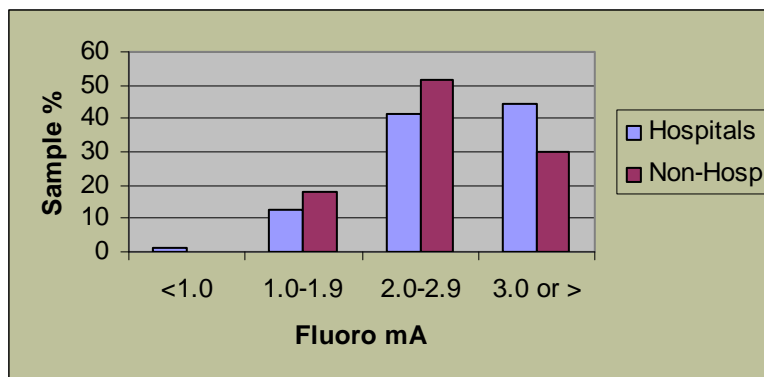

Radiographic image quality—total number of low contrast objects (holes) observed in radiographic (digital or film) image of test tool for hospitals (H)/non-hospitals (N/H)

Number Holes Visible	Frequency		Percent		Cum Freq	
	H	N/H	H	N/H	H	N/H
1	0	0	0	0	0	0
2	2	0	1.4	0	2	0
3	6	5	4.3	14.3	8	5
4	57	11	40.7	31.4	65	16
5	50	14	35.7	40	115	30
6	19	4	13.6	11.4	134	34
7	4	1	2.9	2.9	138	35
8	2	0	1.4	0	140	35

Statistics for hospitals (H)/non-hospitals (N/H)

Minimum		Q1		Median		Q3		Max		Mean		Std Dev	
H	N/H	H	N/H	H	N/H	H	N/H	H	N/H	H	N/H	H	N/H
2	3	4	4	5	5	5	5	8	7	4.7	4.6	1.0	0.97

Combined statistics for all facilities

Q1	Median	Q3	Mean	Std Dev
4	5	5	4.7	0.99

Distribution of radiographic (digital or film) test tool low contrast object (hole) scores

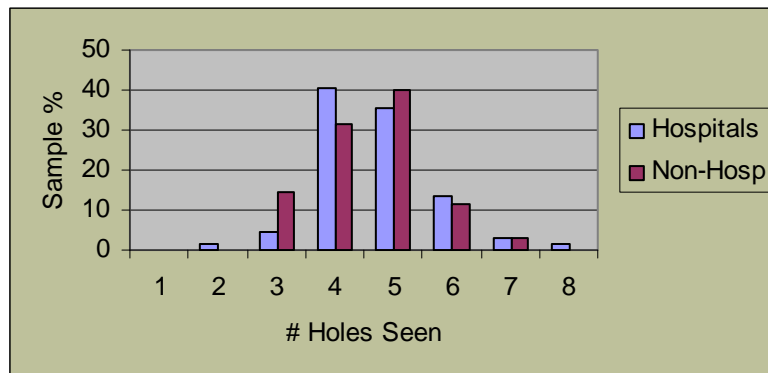

Radiographic image quality—total number of high contrast objects (meshes) observed in radiographic (digital or film) image of test tool for hospitals (H)/non-hospitals (N/H)

Number Meshes Visible	Frequency		Percent		Cum Freq	
	H	N/H	H	N/H	H	N/H
1	0	0	0	0	0	0
2	0	0	0	0	0	0
3	0	1	0	2.9	0	1
4	28	7	20	20	28	8
5	77	16	55	45.7	105	24
6	21	8	15	22.9	126	32
7	14	3	10	8.6	140	35
8	0	0	0	0	140	35

Statistics for hospitals (H)/non-hospitals (N/H)

Minimum		Q1		Median		Q3		Max		Mean		Std Dev	
H	N/H	H	N/H	H	N/H	H	N/H	H	N/H	H	N/H	H	N/H
4	3	5	5	5	5	5.3	6	7	7	5	5	0.85	0.94

Combined statistics for all facilities

Q1	Median	Q3	Mean	Std Dev
5	5	6	5	0.87

Distribution of radiographic (digital or film) test tool high contrast (mesh) object scores



Measured optical density of radiographic images
for hospitals (H)/non-hospitals (N/H)

Optical Density	Frequency		Percent		Cum Freq	
	H	N/H	H	N/H	H	N/H
< 0.5	5	0	4.5	0	5	0
0.5-0.99	27	5	24.5	19.2	32	5
1.0-1.49	52	11	47.3	42.3	84	16
1.5-1.99	19	7	17.3	26.9	103	23
2.0 or >	7	3	6.4	11.5	110	26

Statistics for hospital (H)/non-hospital (N/H)

Minimum		Q1		Median		Q3		Maximum		Mean		Std Dev	
H	N/H	H	N/H	H	N/H	H	N/H	H	N/H	H	N/H	H	N/H
0.3	0.7	0.9	1.1	1.2	1.3	1.5	1.6	3.2	2.6	1.2	1.4	0.5	0.4

Measured darkroom fog for hospitals (H)/non-hospitals (N/H)

Optical Density	Frequency		Percent		Cum Freq	
	Hosp	N/H	Hosp	N/H	Hosp	N/H
< 0.02	12	7	23.1	36.8	12	7
0.02-0.04	20	6	38.5	31.6	32	13
0.05-0.11	11	3	21.2	15.8	43	16
0.12-0.19	4	1	7.7	5.3	47	17
0.2-0.40	2	2	3.8	10.5	49	19
> 0.40	3	0	5.8	0	52	19

Statistics for hospital (H)/non-hospital (N/H)

Minimum		Q1		Median		Q3		Maximum		Mean		Std Dev	
H	N/H	H	N/H	H	N/H	H	N/H	H	N/H	H	N/H	H	N/H
0	0	0.02	0.01	0.03	0.02	0.08	0.07	0.7	0.23	0.08	0.05	0.13	0.07

Processing speed index (STEP)*
for hospitals (H)/non-hospitals (N/H)

STEP Index Number	Frequency		Percent		Cum Freq	
	H	N/H	H	N/H	H	N/H
< 80	0	0	0	0	0	0
80 - 89	4	1	5.3	4.3	4	1
90 - 99	18	3	24	13	22	4
100-109	23	10	30.7	43.5	45	14
110-119	18	7	24	30.4	63	21
> 119	12	2	16	8.7	75	23

* Sensitometric Technique for the Evaluation of Processing

Statistics for hospital (H)/non-hospital (N/H)

Minimum		Q1		Median		Q3		Maximum		Mean		Std Dev	
H	N/H	H	N/H	H	N/H	H	N/H	H	N/H	H	N/H	H	N/H
84	84	98	107	108	110	113	115	137	122	107	109	11.5	8.97

Distribution of processing speed index

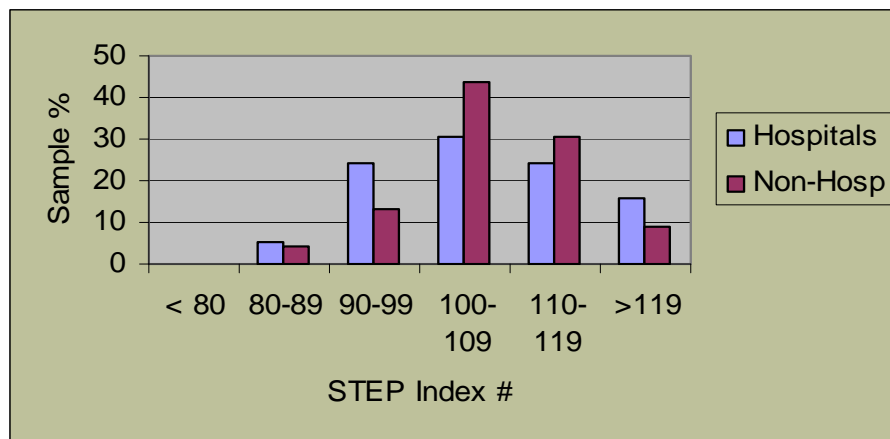

PART TWO

DOSE/EXPOSURE RESULTS FOR FLUOROSCOPY UNITS WITH UNDER TABLE TUBES

The information in this section is also presented in a manner that contrasts the findings for facilities designated as hospitals with those of non-hospital facilities. Rather than presenting dose, data is presented as measured entrance air kerma, and additionally, in the distribution tables, the corresponding exposure results (in terms of Roentgens) are also given, taking into consideration that this unit may be more familiar to some readers.

Fluoroscopic and radiographic doses (and exposures), unless otherwise noted, are calculated at one centimeter above the table top in accordance with 21 CFR 1020.32, so that interested parties may make comparisons with their own experiences. Air kerma is measured using an FDA developed fluoroscopic phantom, which is placed on the table top above the ionization chamber, which is located about 3.5 cm from where the x-ray beam enters the phantom.

The x-ray field is collimated to the size of the phantom. A copper filter is added to the beam to simulate a fluoroscopic contrast agent (barium) and a sheet of lead is added to obtain a maximum exposure rate. In addition to dose being measured in the fluoroscopic mode, it is also measured for a single radiographic image. The total entrance dose from all radiographic images was estimated by multiplying the dose obtained for a single radiographic image by the typical number of such images taken at the facility during the procedure. In this report, dose (and corresponding exposure) in radiographic (recording) mode are reported using the data that simulated the use of contrast agents.

The image quality test object that was imaged and scored consists of a series of eight copper mesh screens (20 to 120 wires/inch), and a 6.1 mm thick aluminum disk that has eight holes (7.94 mm diameter each) bored to different depths (the test object is fully described in the protocol for performing this survey).

The fact that some surveys were incomplete is reflected in the cumulative frequency columns of the data tables. In most cases, missing or indeterminate results are ignored. However, in some instances the sample percent that is unknown is stated.

Abbreviations used in the statistics tables are the same as indicated in Part One.

Fluoroscopic entrance air kerma (EAK) rate and exposure rate 1 cm above table top (using fluoroscopy phantom) for hospitals (H)/non-hospitals (N/H)

EAK (mGy/min)/ Exposure (R/min)	Frequency		Percent		Cum Freq	
	H	/H	H	N/H	H	N/H
<15/1.72	8	2	7.3	7.4	8	2
15-30/1.72-3.44	34	7	31.2	24.1	42	9
31-45/3.55-5.15	23	12	21.1	41.3	65	21
46-60/5.27-6.87	28	3	25.7	10.3	93	24
>60/6.87	16	5	14.7	17.2	109	29

Statistics for hospital (H)/non-hospital (N/H)

	Minimum		Q1		Median		Q3		Maximum		Mean		Std Dev	
	H	N/H	H	N/H	H	N/H	H	N/H	H	N/H	H	N/H	H	N/H
mGy/min	3.2	7.5	25.7	27.7	37.9	40.1	55.5	47.4	92.7	77.0	40.1	37.9	19.3	18.6
R/min	0.3	0.8	2.9	3.2	4.5	4.3	6.4	5.4	10.6	8.8	4.6	4.6	2.2	2.1

Combined statistics for all facilities surveyed

	Q1	Median	Q3	Mean	Std Dev
mGy/min	26.2	39.5	55.5	37.9	19.3
R/min	3.0	4.5	6.4	4.6	2.2

Table top entrance air kerma rate distribution for hospitals (H)/non-hospitals (N/H)

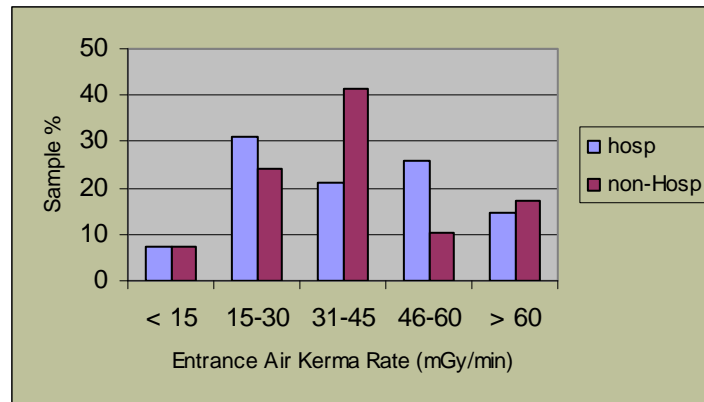

Fluoroscopic entrance air kerma (EAK) rate and exposure rate 1 cm above table top for digital (Dig) vs film recording mode

EAK (mGy/min) / Exposure (R/min)	Frequency		Percent		Cum Freq	
	Dig	Film	Dig	Film	Dig	Film
< 15 / 1.72	10	0	12.0	0	10	0
15-30 / 1.72-3.44	23	17	27.7	30.9	33	17
31-45 / 3.55 -5.15	18	18	21.7	32.7	51	35
46 – 60 / 5.27-6.87	20	10	24.1	18.2	71	45
> 60 / 6.87	12	10	14.5	18.2	83	55

Statistics for digital (Dig)/film

	Minimum		Q1		Median		Q3		Maximum		Mean		Std Dev	
	Dig	Film	Dig	Film	Dig	Film	Dig	Film	Dig	Film	Dig	Film	Dig	Film
mGy/min	2.8	16.5	23.7	27.1	37.8	40.9	54.7	56.1	84.1	92.7	38.9	43.1	19.6	19.0
R/min	0.3	1.9	2.7	3.1	4.3	4.7	6.3	6.4	9.6	10.6	4.5	4.9	2.2	2.2

Table top entrance air kerma rate distribution for digital vs. film recording mode

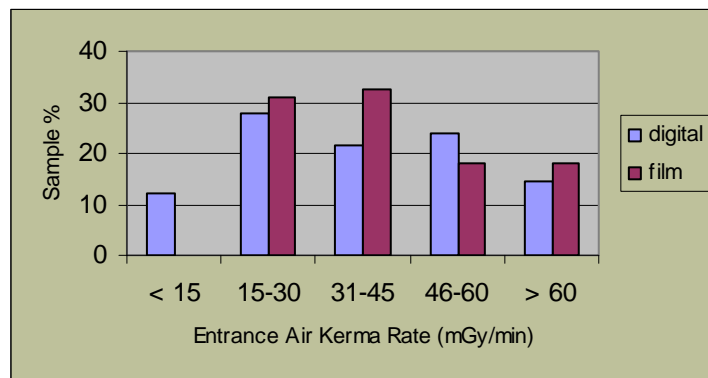

Fluoroscopic entrance air kerma (EAK) rate and exposure rate 1 cm above table top with NEXT fluoroscopy phantom & copper filter for hospitals (H)/non-hospitals (N/H)

EAK (mGy/min) / Exposure (R/min)	Frequency		Percent		Cum Freq	
	H	N/H	H	N/H	H	N/H
< 15 / 1.72	2	1	1.8	3.6	2	1
15-30 / 1.72-3.44	6	1	5.5	3.6	8	2
31-45 / 3.55 -5.15	7	0	6.4	0	15	2
46 – 60 / 5.27-6.87	15	5	13.8	17.8	30	7
> 60 / 6.87	79	21	72.5	75	109	28

Statistics for hospital/non-hospital

	Minimum		Q1		Median		Q3		Maximum		Mean		Std Dev	
	H	N/H	H	N/H	H	N/H	H	N/H	H	N/H	H	N/H	H	N/H
mGy/min	6.3	2.9	57.1	62.7	71.2	74.7	80.5	78.7	112	93.1	67.1	68.5	19.4	19.4
R/min	0.7	0.3	6.5	7.2	8.2	8.6	9.2	9.0	12.8	10.7	7.7	7.8	2.2	2.2

(Note: A 1.6 mm copper filter was added to the NEXT fluoroscopy phantom to simulate a nominal 2mm barium sulfate suspension.)

Table top entrance air kerma rate distribution with NEXT fluoroscopy phantom and copper filter for hospitals/non-hospitals

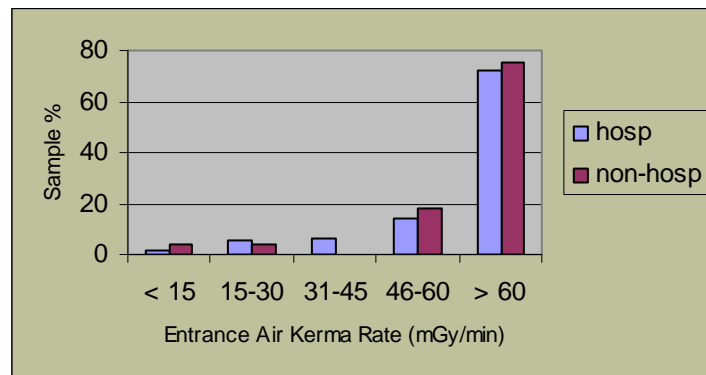

Fluoroscopic entrance air kerma (EAK) rate and exposure rate 1 cm above table top with NEXT fluoroscopy phantom & copper filter for digital (Dig) vs. film recording mode

EAK (mGy/min)/ Exposure (R/min)	Frequency		Percent		Cum Freq	
	Dig	Film	Dig	Film	Dig	Film
<15/1.72	3	0	3.6	0	3	0
15-30/1.72-3.44	4	3	4.8	5.8	7	3
31-45/3.55-5.15	1	6	1.2	11.5	8	9
46-60/5.27-6.87	8	12	9.6	23.1	16	21
>60/6.87	67	31	80.7	59.6	83	52

Statistics for Digital (Dig)/film

	Minimum		Q1		Median		Q3		Maximum		Mean		Std Dev	
	Dig	Film	Dig	Film	Dig	Film	Dig	Film	Dig	Film	Dig	Film	Dig	Film
mGy/min	2.9	23.8	64.8	53.1	73.9	70.4	80.8	78	112	92.9	69	65.2	20.5	17.9
R/min	0.3	2.7	7.4	6.1	8.5	8.1	9.3	8.9	12.8	10.6	7.9	7.5	2.4	2.0

(Note: A 1.6 mm copper filter was added to the NEXT fluoroscopy phantom to simulate a nominal 2mm barium sulfate suspension.)

Table top entrance air kerma rate distribution with NEXT fluoroscopy phantom & copper filter for digital vs. film recording mode

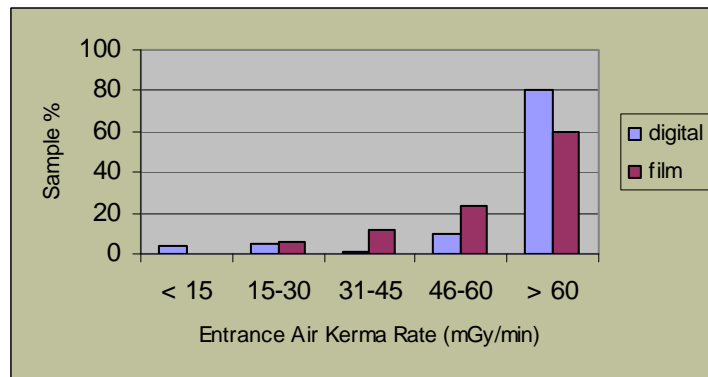

Maximum fluoroscopic entrance air kerma (EAK) rate and exposure rate 1 cm above the table top with NEXT fluoroscopy phantom & lead sheet for hospitals (H)/non-hospitals (N/H)

EAK (mGy/min) / Exposure (R/min)	Frequency		Percent		Cum Freq	
	H	N/H	H	N/H	H	N/H
<45/5.15	13	2	11.9	7.4	13	2
45-60/5.27-6.87	12	4	11.0	14.8	25	6
61-75/6.99-8.59	35	7	32.1	25.9	60	13
76-90/8.71-10.31	38	13	34.9	48.1	98	26
>90/10.31	11	1	10.1	3.7	109	27

Statistics for hospital (H)/non-hospital (N/H)

	Minimum		Q1		Median		Q3		Maximum		Mean		Std Dev	
	H	N/H	H	N/H	H	N/H	H	N/H	H	N/H	H	N/H	H	N/H
mGy/min	6.3	6.0	64.1	67.2	74.3	75.9	83.2	82.8	112	114.4	70	71.5	19	20.9
R/min	0.7	0.7	7.3	7.7	8.5	8.7	9.5	9.5	12.9	13.1	8.0	8.2	2.2	2.4

(Note: A 3.2 mm lead sheet was placed in the beam to drive the system to maximum output.)

Table top maximum entrance air kerma rate distribution for hospitals (H)/non-hospitals (N/H)

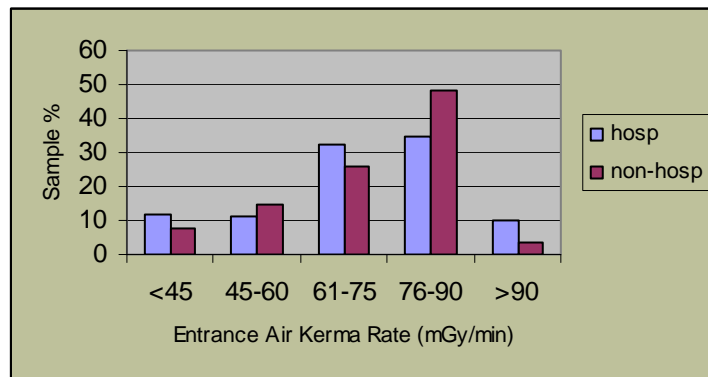

Maximum fluoroscopic entrance air kerma (EAK) rate and exposure rate 1 cm above the table top with NEXT fluoroscopy phantom & lead sheet for digital (Dig) vs. film recording mode

EAK (mGy/min) / Exposure (R/min)	Frequency		Percent		Cum Freq	
	Dig	Film	Dig	Film	Dig	Film
<45/5.15	7	8	8.5	15.4	7	8
46-60/5.27-6.87	6	10	7.3	19.2	13	18
61-75/6.99-8.59	27	12	32.9	23.1	40	30
76-90/8.71-10.31	33	18	40.2	34.6	73	48
> 90/10.31	9	4	11.0	7.7	82	52

Statistics for digital (Dig)/film

	Minimum		Q1		Median		Q3		Maximum		Mean		Std Dev	
	Dig	Film	Dig	Film	Dig	Film	Dig	Film	Dig	Film	Dig	Film	Dig	Film
mGy/min	6.0	23.7	66.2	54.2	75.5	74.4	84.4	80.4	114	93.5	72.3	67.5	20	18.6
R/min	0.7	2.7	7.6	6.2	8.6	8.5	9.7	9.2	13.1	10.7	8.3	7.7	2.3	2.1

(Note: A 3.2 mm lead sheet was placed in the beam to drive the system to maximum output.)

Table top maximum entrance air kerma rate distribution for digital vs. film recording mode

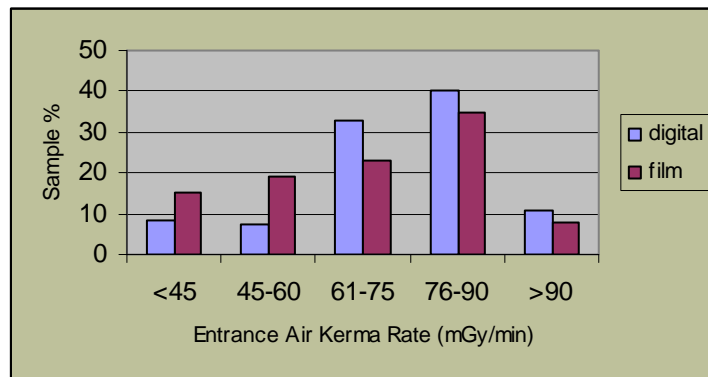

Entrance air kerma (EAK) and exposure at 1 cm above table top for a single radiographic Image for hospitals (H)/non-hospitals (N/H)

EAK (mGy)/ Exposure (mR)	Frequency		Percent		Cum Freq	
	H	N/H	H	N/H	H	N/H
<1/115	35	7	35.4	25.9	35	7
1-2/115-229	27	9	27.3	33.3	62	16
2.1-3/241-344	20	5	20.2	18.5	82	21
3.1-5/355-573	13	3	13.1	11.1	95	24
>5/573	4	3	4.0	11.1	99	27

Statistics for hospital/non-hospital

	Minimum		Q1		Median		Q3		Maximum		Mean		Std Dev	
	H	N/H	H	N/H	H	N/H	H	N/H	H	N/H	H	N/H	H	N/H
mGy	0.09	0.17	0.8	1.03	1.5	1.7	2.5	2.9	9.6	5.8	1.96	2.2	1.7	1.57
mR	10	19.8	90.3	118	169	197	290	332	1100	662	225	248	192	180

Combined statistics for all facilities surveyed

	Q1	Median	Q3	Mean	Std Dev
mGy	0.81	1.58	2.65	2.01	1.65
mR	93	181	303	230	189

Entrance air kerma distribution 1 cm above table top for a single radiographic image

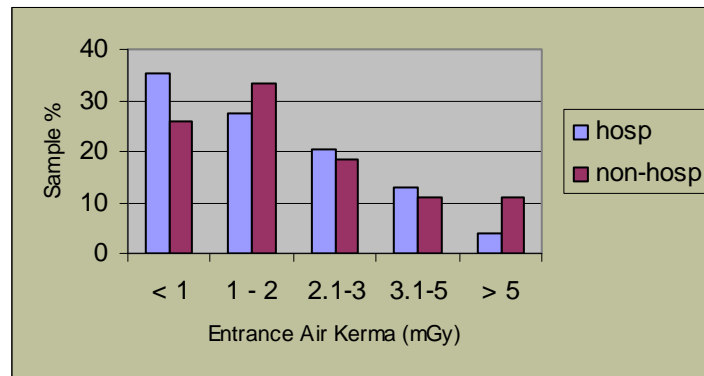

Entrance air kerma (EAK) and exposure at 1 cm above table top for a single radiographic image for digital (Dig) vs. film recording mode

EAK (mGy) / Exposure (mR)	Frequency		Percent		Cum Freq	
	Dig	Film	Dig	Film	Dig	Film
<1/115	40	2	55.5	3.8	40	2
1-2/115- 229	20	15	27.8	28.8	60	17
2.1-3/241-344	8	15	11.1	28.8	68	32
3.1-5/355-573	2	14	2.8	26.9	70	46
> 5/573	2	6	2.8	11.5	72	52

Statistics for digital (Dig)/film

	Minimum		Q1		Median		Q3		Maximum		Mean		Std Dev	
	Dig	Film	Dig	Film	Dig	Film	Dig	Film	Dig	Film	Dig	Film	Dig	Film
mGy	0.1	0.09	0.6	1.8	0.9	2.5	1.5	3.9	6.0	9.6	1.3	3.1	1.08	1.9
mR	12	10.5	72.3	207	106	290	172	451	683	1100	146	351	123	212

Entrance air kerma distribution 1 cm above table top for a single radiographic image using digital vs. film recording mode

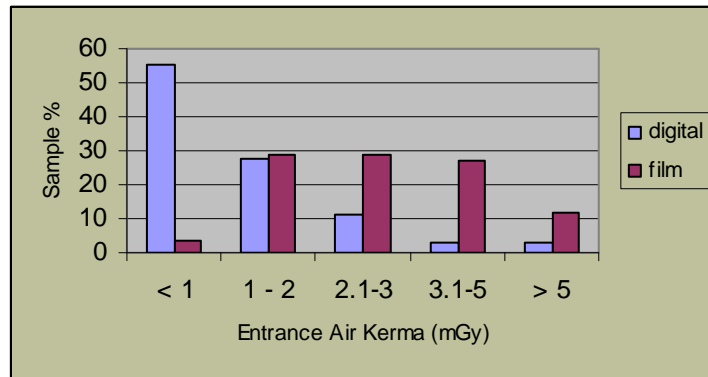

Entrance air kerma (EAK) and exposure at 1 cm above table top for a single radiographic image with copper filter for hospitals (H)/non-hospitals (N/H)

EAK (mGy)/ Exposure (mR)	Frequency		Percent		Cum Freq	
	H	N/H	H	N/H	H	N/H
<1/115	5	1	5.1	3.8	5	1
1-2/115-229	6	1	6.1	3.8	11	2
2.1-3/241-344	9	2	9.2	7.7	20	4
3.1-5/355-573	12	3	12.3	11.5	32	7
>5/573	66	19	67.3	73.1	98	26

Statistics for hospital (H)/non-hospital (N/H)

	Minimum		Q1		Median		Q3		Maximum		Mean		Std Dev	
	H	N/H	H	N/H	H	N/H	H	N/H	H	N/H	H	N/H	H	N/H
mGy	0.14	0.86	3.9	4.5	7.9	11.7	19.3	21.7	102.3	86.8	14.8	17.5	18.3	19.6
mR	17	98	444	520	901	1342	2209	2481	11717	9944	1690	2004	2094	2248

Combined statistics for all facilities surveyed

	Q1	Median	Q3	Mean	Std Dev
mGy/min	3.96	9.0	20.9	15.3	18.5
R/min	454	1026	2399	1756	2122

(Note: A 1.6 mm copper filter was added to the NEXT fluoroscopy phantom to simulate a nominal 2 mm barium sulfate suspension.)

Entrance air kerma distribution at 1 cm above table top for a single radiographic image with copper filter

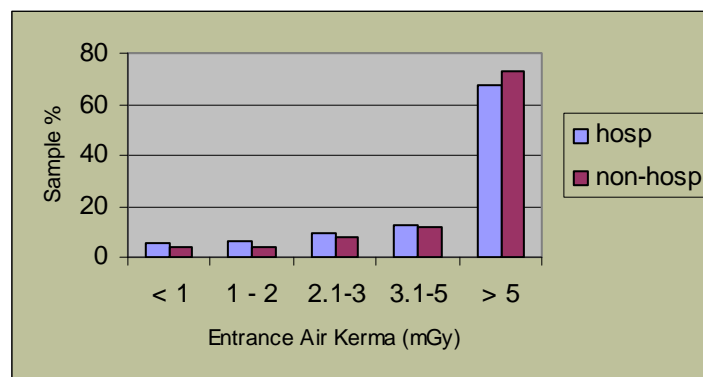

Entrance air kerma (EAK) and exposure at 1 cm above table top for a single radiographic image with copper filter for digital (Dig) vs. film recording mode

EAK (mGy) / Exposure (mR)	Frequency		Percent		Cum Freq	
	Dig	Film	Dig	Film	Dig	Film
<1/115	5	1	6.9	2.0	5	1
1-2/115-229	7	0	9.7	0	12	1
2.1-3/241-344	10	1	13.9	2.0	22	2
3.1-5/355-573	12	2	16.6	4.0	34	4
>5/573	38	46	52.8	92.0	72	50

Statistics for digital/film

	Minimum		Q1		Median		Q3		Maximum		Mean		Std Div	
	Dig	Film	Dig	Film	Dig	Film	Dig	Film	Dig	Film	Dig	Film	Dig	Film
mGy	0.15	0.5	2.7	9.9	5.3	18.7	9.9	27.5	80.6	102	9.1	24.4	12.1	22.5
mR	17	60	306	1138	602	2144	1136	3148	9233	11717	1046	2792	1388	2579

Entrance air kerma distribution at 1 cm above table top for a single radiographic Image with copper filter for digital vs. film recording mode

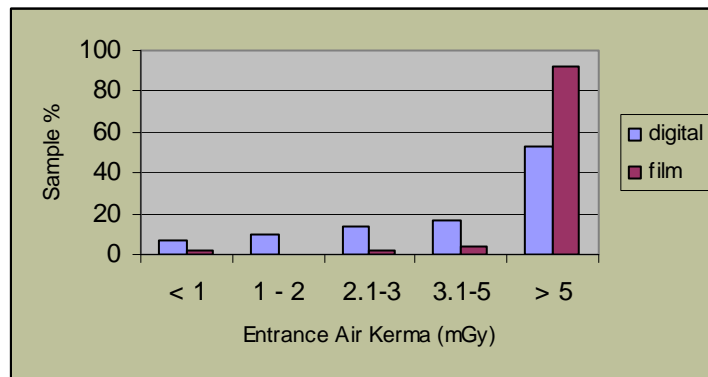

Total number of recording mode exposures during upper G.I. examination for hospitals (H)/non-hospitals (N/H)

Total Number of Exposures	Frequency		Percent		Cum Freq	
	H	N/H	H	N/H	H	N/H
<5	11	3	17.7	14.3	11	3
5-10	16	4	25.8	19	27	7
11-19	31	13	50	61.9	58	20
20 or >	4	1	6.5	4.8	62	21

Minimum		Q1		Median		Q3		Maximum		Mean		Std Dev	
H	N/H	H	N/H	H	N/H	H	N/H	H	N/H	H	N/H	H	N/H
2	1	8	9	11	13	15	17	31	22	11	12	5.6	6.1

Total entrance air kerma (EAK) and exposure (R) at 1 cm above table top from all recording mode images
(average exposure value with simulated contrast from surveyed unit at each facility multiplied by total number of exposures at that facility)

EAK (mGy)/ Exposure (R)	Frequency		Percent		Cum Freq	
	H	N/H	H	N/H	H	N/H
<40/4.6	11	2	22	11.8	11	2
40-99/4.6-11.3	10	2	20	11.8	21	4
100-199/11.5-22.8	11	6	22	35.3	32	10
200-500/22.9-57.3	12	4	24	23.5	44	14
>500/57.3	6	3	12	17.6	50	17

Statistics for hospital (H)/ non-hospital (N/H)

	Minimum		Q1		Median		Q3		Maximum		Mean		Std Dev	
	H	N/H	H	N/H	H	N/H	H	N/H	H	N/H	H	N/H	H	N/H
mGy	4	3.5	50	110	148	145	266	401	1125	1060	213	290	238	305
R	0.5	0.4	5.77	12.6	16.9	16.6	30.4	45.9	129	121	24.4	33.3	27.3	34.9

Combined statistics for all facilities surveyed

	Q1	Median	Q3	Mean	Std Dev
mGy	56.7	145.8	320.4	232.2	256.7
R	6.5	16.7	36.7	26.6	29.4

PART THREE

DOSE/EXPOSURE RESULTS FOR FLUOROSCOPY UNITS WITH OVER TABLE TUBES

Thirteen of the facilities surveyed had over table x-ray tubes. Because of the different beam geometry, direct comparisons of measured doses (exposures) with the results obtained for under table tubes can be misleading. This part of the survey therefore separately reports the direct dose related findings for these 13 units. The over table units were otherwise treated the same and all other survey results for over table tubes, for example, workload data, technique factors, contrast protocol, etc., are included in the findings reported in Part One.

As in Part Two, air kerma values are presented with the corresponding exposure values being included also in the distribution tables. Fluoroscopic and radiographic dose rates, unless otherwise noted, are calculated at 30 cm above the table top in accordance with 21 CFR 1020.32, so that interested parties may make comparisons with their own experiences. Air kerma is measured using an FDA developed fluoroscopic phantom, which is placed on the table top above the ionization chamber, which is located about 3.5 cm from where the x-ray beam exits the phantom.

The x-ray field is collimated to the size of the phantom. A copper filter is added to the beam to simulate fluoroscopic contrast agents and a sheet of lead is added to obtain a maximum exposure rate. In addition to dose being measured in fluoroscopic mode, dose is also measured for a single spot film. As in Part Two, the total dose from all radiographic images was estimated by multiplying the dose obtained for a single radiographic image by the typical number of such images taken at the facility during the procedure. Dose (and corresponding exposure) in radiographic (recording) mode are reported using the data that simulated the use of contrast agents.

Some surveys were incomplete, and this is reflected in the cumulative frequency columns of the data tables. In most cases, missing or indeterminate results are ignored. However, in some instances the sample percent that is unknown is stated.

The image quality test object that was imaged and scored is the same as that which is described in the opening notes to Part One.

Abbreviations used in the statistics tables are the same as indicated in Part One.

Fluoroscopic air kerma rate (AKR) /exposure rate 30 cm above table top using NEXT fluoroscopy phantom

AKR (mGy/min)/ Exposure Rate (R/min)	Frequency	Percent	Cum Freq
<15/1.72	3	23.1	3
15-30/1.72-3.44	6	46.2	9
31-45/3.55-5.15	1	7.7	10
46-60/5.27-6.87	1	7.7	11
>60/ 6.87	2	15.4	13

Statistics for all over table units

	Minimum	Q1	Median	Q3	Maximum	Mean	Std Dev
mGy/min	3.05	20.82	26.50	36.67	63.85	29.39	18.84
R/min	0.35	2.39	3.03	4.20	7.31	3.37	2.16

Air kerma rate distribution 30 cm above the table top using NEXT fluoroscopy phantom

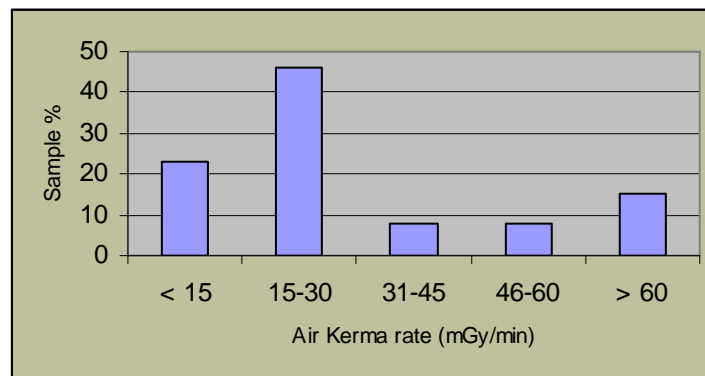

Fluoroscopic air kerma rate (AKR)/exposure rate 30 cm above table top
using NEXT fluoroscopy phantom and copper filter

AKR (mGy/min)/ Exposure (R/min)	Frequency	Percent	Cum Freq
<15/1.72	2	15.4	2
15-30/1.72-3.44	0	0	2
31-45/3.55-5.15	1	7.7	3
46-60/5.27-6.87	4	30.8	7
>60/6.87	6	46.2	13

Statistics for all over table units

	Minimum	Q1	Median	Q3	Maximum	Mean	Std Dev
mGy/min	11.90	46.03	58.25	68.02	80.58	54.09	21.65
R/min	1.36	5.27	6.67	7.79	9.23	6.20	2.48

(Note: A 1.6 mm copper filter was added to the phantom to simulate a nominal 2mm
barium sulfate suspension.)

Air kerma rate distribution 30 cm above the table top
using fluoroscopy phantom and copper filter

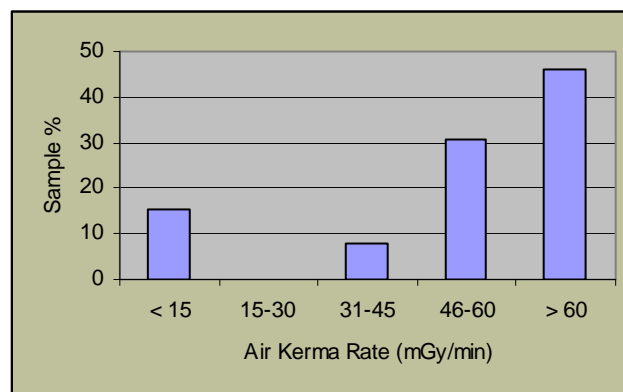

Maximum air kerma rate (AKR)/exposure rate 30 cm above the table top with NEXT fluoroscopy phantom and lead sheet

AKR (mGy/min)/ Exposure (R/min)	Frequency	Percent	Cum Freq
<15/1.72	0	0	0
15-30/1.72-3.44	2	15.4	2
31-45/3.55-5.15	2	15.4	4
46-60/5.27-6.87	1	7.7	5
>60/6.87	8	61.5	13

Statistics for all over table units

	Minimum	Q1	Median	Q3	Maximum	Mean	Std Dev
mGy/min	17.31	43.63	65.23	79.19	105.17	60.98	25.07
R/min	1.98	4.99	7.47	9.07	12.05	6.99	2.87

(Note: A 3.2 mm lead sheet was placed in the beam to drive the system to maximum output.)

Air kerma rate distribution 30 cm above the table top using NEXT fluoroscopy phantom and lead sheet

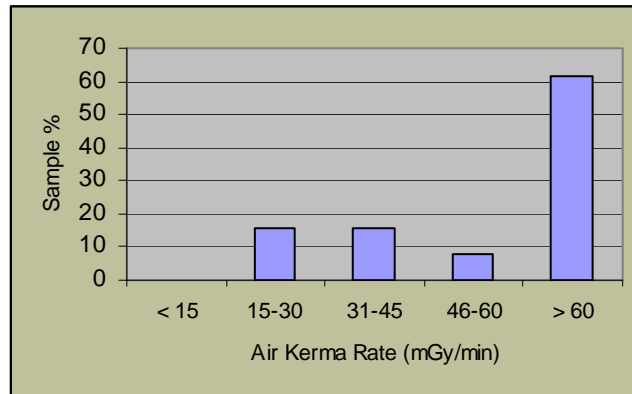

Air kerma/exposure measured at 30 cm above table top
for a single radiographic image using the NEXT fluoroscopy phantom

Air Kerma (mGy/ Exposure (mR))	Frequency	Percent	Cum Freq
<1/115	5	38.5	5
1-2/115-229	4	30.8	9
2.1-3.0/241-344	2	15.4	11
3.1-5.0/355-573	0	0	11
>5/573	1	7.7	13

Statistics for all over table units

	Minimum	Q1	Median	Q3	Maximum	Mean	Std Dev
mGy	0.39	0.75	1.34	1.91	5.66	1.60	1.43
mR	44.4	86.2	153.7	219.2	648.1	183.5	164.2

Measured air kerma distribution at 30 cm above table top
for a single radiographic image

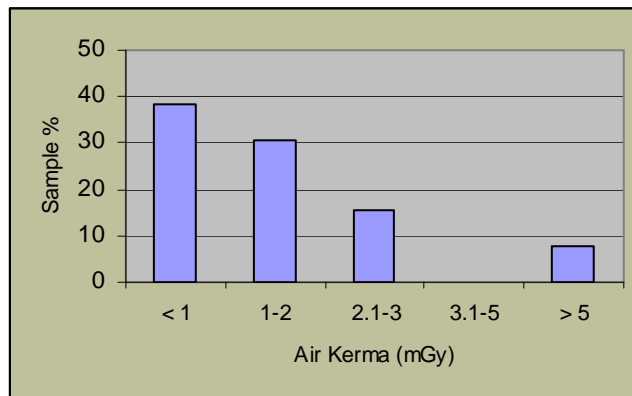

Air kerma/exposure measured at 30 cm above table top for a single radiographic image with NEXT fluoroscopy phantom and copper filter

Air Kerma (mGy/ Exposure (mR))	Frequency	Percent	Cum Freq
<1/115	0	0	0
1-2/115-229	2	16.7	2
2.1-3.0/241-344	0	0	2
3.1-5.0/355-573	4	33.3	6
>5/573	6	50.0	12

Statistics for all over table units

	Minimum	Q1	Median	Q3	Maximum	Mean	Std Dev
mGy	1.37	3.26	4.87	9.84	17.71	6.74	4.92
mR	157	373	558	1127	2029	772	563

(Note: A 1.6 mm copper filter was added to the NEXT fluoroscopy phantom to simulate a nominal 2 mm barium sulfate suspension.)

Air kerma distribution at 30 cm above table top for a single radiographic image using NEXT fluoroscopy phantom & copper filter

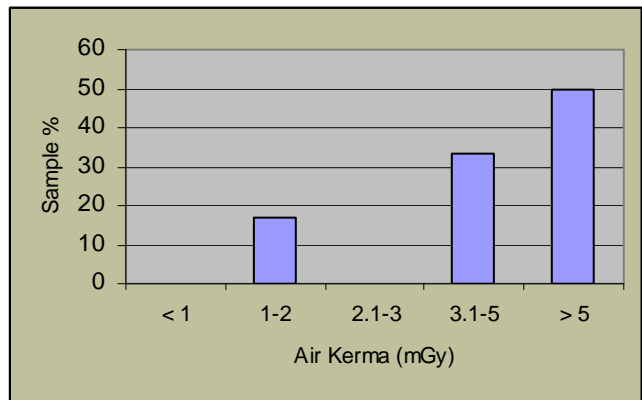

Total number of recording mode exposures
made during upper G.I. examination

Total Number of Exposures	Frequency	Percent	Cum Freq
<5	1	14.3	1
5-10	2	28.6	3
11-19	3	42.9	6
20 or >	1	14.3	7

Statistics for all over table units

Minimum	Q1	Median	Q3	Maximum	Mean	Std Dev
2	8	12	15.5	21	11.7	6.4

Total air kerma/ exposure 30 cm above table top from all radiographic images
(single exposure value for each facility with simulated contrast multiplied by total
number of exposures at that facility)

Air Kerma (mGy/ Exposure (mR)	Frequency	Percent	Cum Freq
<40/4.6	2	28.6	2
40-99/4.6-11.3	2	28.6	4
100-199/11.5-22.8	2	28.6	6
200-500/22.9-57.3	1	14.3	7
>500/57.3	0	0	7

PART FOUR

RESULTS OF FACILITY PRACTICE SURVEY

As a part of the upper G.I. fluoroscopy survey a questionnaire was distributed to each facility that participated. As a practical matter, facilities responded to this survey at about the same time as the NEXT surveyor visited to collect their data. However, the survey was of a more general nature and, not being only focused on upper G.I. fluoroscopy, could be considered to stand on its own. In addition to some questions about upper G.I. equipment, others were directed to topics such as facility staffing, the typical procedures done at the facility, physics quality assurance testing, and interventional radiology. Information of this nature is useful for keeping abreast of the types and numbers of radiological procedures that are typically being performed.

Patient dose as a result of interventional procedures has become more of a concern over the past several years because the number being conducted has increased and new types of procedures are being introduced. Additionally, unavoidably long fluoroscopy times are often encountered in some cases. As a result of long exposure times and in some cases the need for the patient to undergo a second or third interventional procedure, patients may receive very high cumulative doses, even though x-ray equipment may meet federal regulations on radiation output.

To raise awareness about this, many health care professionals have advocated that the users of this equipment should have appropriate training regarding the radiation risks. This would hopefully serve to minimize the doses that patients are subject to as much as possible.

One hundred forty-five hospitals and 35 non-hospital facilities responded to this survey. Some statistics were computed where it appeared to have some relevance in understanding the results. There were cases where the data could not be categorized, and the responses we received are simply listed. Generally an answer of 0 was counted as a response for calculation of percentages, averages, etc., while a blank response was ignored.

Facility Staffing

Number of x-ray technologists on staff

Number of Technologists	Frequency		Percent		Cum Freq	
	H	N/H	H	N/H	H	N/H
<5	10	13	7.0	37.1	10	13
5–24	84	19	58.7	54.3	94	32
25–49	33	3	23.1	8.6	127	35
50–74	9	0	6.3	0	136	35
75-100	4	0	2.8	0	140	35
>100	3	0	2.1	0	143	35

Minimum		Q1		Median		Q3		Maximum		Mean		Std Dev	
H	N/H	H	N/H	H	N/H	H	N/H	H	N/H	H	N/H	H	N/H
2	0	13	4	18	6	13	4	124	42	26	10	23	10

Number of radiologists on staff

Number of Radiologists	Frequency		Percent		Cum Freq	
	H	N/H	H	N/H	H	N/H
<3	35	11	24.4	31.4	35	11
3–9	66	16	46.2	45.7	101	27
10–19	26	6	18.2	17.1	127	33
20–40	12	2	8.4	5.7	139	35
>40	4	0	2.8	0	143	35

Minimum		Q1		Median		Q3		Maximum		Mean		Std Dev	
H	N/H	H	N/H	H	N/H	H	N/H	H	N/H	H	N/H	H	N/H
0	0	3	2	5	4	11	7	72	25	9	6	11.2	6.5

Facility Staffing

Number of medical physicists on staff

Number of Physicists	Frequency		Percent		Cum Freq	
	H	N/H	H	N/H	H	N/H
0	91	26	74.6	92.9	91	26
1	20	1	16.4	3.6	111	27
2	8	0	6.6	0	119	27
3-5	2	0	1.6	0	121	27
>	1	1	0.8	3.6	122	28

Minimum		Q1		Median		Q3		Maximum		Mean		Std Dev	
H	N/H	H	N/H	H	N/H	H	N/H	H	N/H	H	N/H	H	N/H
0	0	0	0	0	0	0.75	0	12	14	0.5	0.5	1.3	2.6

Number of contract medical physicists employed

Number of Physicists	Frequency		Percent		Cum Freq	
	H	N/H	H	N/H	H	N/H
0	16	2	11.8	5.7	16	2
1	87	26	64	74.3	103	28
2	18	4	13.2	11.4	121	32
3 – 5	15	2	11	5.7	136	34
> 5	0	1	0	2.9	136	35

Minimum		Q1		Median		Q3		Maximum		Mean		Std Dev	
H	N/H	H	N/H	H	N/H	H	N/H	H	N/H	H	N/H	H	N/H
0	0	1	1	1	1	1	1	5	10	1.3	1.4	0.9	1.6

Radiographic Exams

Estimated number of general radiographic exams
performed each month at all facilities

Number of Procedures	Frequency		Percent		Cum Freq	
	H	N/H	H	N/H	H	N/H
<500	13	13	9.1	39.4	13	13
500–900	19	10	13.2	30.3	32	23
1000–1900	41	5	28.7	15.1	73	28
2000–3900	37	3	25.8	9.1	110	31
4000-6000	17	0	11.9	0	127	31
>6000	16	2	11.2	6.1	143	33

Minimum		Q1		Median		Q3		Maximum		Mean		Std Dev	
H	N/H	H	N/H	H	N/H	H	N/H	H	N/H	H	N/H	H	N/H
4	78	1079	320	1900	600	3556	1000	48071	13100	3614	1380	6332	2449

Estimated number of portable radiographic exams
performed each month at all facilities

Number of Procedures	Frequency		Percent		Cum Freq	
	H	N/H	H	N/H	H	N/H
<100	26	23	18.6	95.8	26	23
100–299	39	0	27.8	0	65	23
300–699	31	1	22.1	4.2	96	24
700–1099	12	0	8.6	0	108	24
1100-2000	16	0	11.4	0	124	24
>2000	16	0	11.4	0	140	24

Minimum		Q1		Median		Q3		Maximum		Mean		Std Dev	
H	N/H	H	N/H	H	N/H	H	N/H	H	N/H	H	N/H	H	N/H
0	0	140	0	330	0	898	0	8995	512	837	23	1353	104

Radiographic Exams

Estimated number of general purpose fluoroscopic exams performed each month at all facilities

Number of Procedures	Frequency		Percent		Cum Freq	
	H	N/H	H	N/H	H	N/H
<25	25	8	17.6	23.5	25	8
25-99	50	14	35.2	41.2	75	22
100-199	37	7	26.0	20.5	112	29
200-399	19	3	13.3	8.8	131	32
400-1000	9	1	6.3	2.9	140	33
>1000	2	1	14.0	2.9	142	34

Minimum		Q1		Median		Q3		Maximum		Mean		Std Dev	
H	N/H	H	N/H	H	N/H	H	N/H	H	N/H	H	N/H	H	N/H
2	1	39	25	86	52	180	100	1101	2300	147	154	186	396

Estimated number of special purpose fluoroscopic exams performed each month at all facilities

Number of Procedures	Frequency		Percent		Cum Freq	
	H	N/H	H	N/H	H	N/H
0	36	19	29.3	82.6	36	19
1-49	30	3	24.4	13.0	66	22
50-199	26	1	21.1	4.3	92	23
200-399	16	0	13.0	0	108	23
400-1000	12	0	9.8	0	120	23
>1000	3	0	2.4	0	123	23

Minimum		Q1		Median		Q3		Maximum		Mean		Std Dev	
H	N/H	H	N/H	H	N/H	H	N/H	H	N/H	H	N/H	H	N/H
0	0	0	0	30	0	194	0	5545	60	180	6	537	16

Radiographic Exams

Estimated number of screening mammographic exams
performed each month at all facilities

Number of Procedures	Frequency		Percent		Cum Freq	
	H	N/H	H	N/H	H	N/H
<25	16	4	11.7	13.3	16	4
25-99	23	1	16.9	3.3	39	5
100-199	20	4	14.7	13.3	59	9
200-399	34	10	25.0	33.3	93	19
400-1000	39	10	28.7	33.3	132	29
>1000	4	1	2.9	3.3	136	30

Minimum		Q1		Median		Q3		Maximum		Mean		Std Dev	
H	N/H	H	N/H	H	N/H	H	N/H	H	N/H	H	N/H	H	N/H
0	0	68	158	243	330	452	422	5000	1100	359	372	562	306

Estimated number of diagnostic mammographic exams
performed each month at all facilities

Number of Procedures	Frequency		Percent		Cum Freq	
	H	N/H	H	N/H	H	N/H
<25	57	9	43.2	34.6	57	9
25-99	29	7	21.9	26.9	86	16
100-199	20	4	15.1	15.3	106	20
200-399	16	5	12.1	19.2	122	25
400-1000	8	1	6.1	3.8	130	26
>1000	2	0	1.5	0	132	26

Minimum		Q1		Median		Q3		Maximum		Mean		Std Dev	
H	N/H	H	N/H	H	N/H	H	N/H	H	N/H	H	N/H	H	N/H
0	0	5	0	40	63	167	138	1200	752	120	115	196	163

Radiographic Exams

Estimated number of magnetic resonance imaging exams
performed each month at all facilities

Number of Procedures	Frequency		Percent		Cum Freq	
	H	N/H	H	N/H	H	N/H
<25	26	5	19.8	17.2	26	5
25-99	12	4	9.2	13.8	38	9
100-199	23	2	17.5	7.0	61	11
200-399	28	10	21.4	34.5	89	21
400-1000	36	8	27.5	27.5	125	29
>1000	6	0	4.6	0	131	29

Minimum		Q1		Median		Q3		Maximum		Mean		Std Dev	
H	N/H	H	N/H	H	N/H	H	N/H	H	N/H	H	N/H	H	N/H
0	0	83	60	200	250	470	400	5570	900	363	273	597	247

Estimated number of computed tomography exams
performed each month at all facilities

Number of Procedures	Frequency		Percent		Cum Freq	
	H	N/H	H	N/H	H	N/H
<250	21	16	15.1	13.3	21	16
250-499	32	5	23.0	15.6	53	21
500-749	22	5	15.8	15.6	75	26
750-999	12	4	8.6	12.5	87	30
1000-2000	31	1	22.3	3.1	118	31
>2000	21	1	15.1	3.1	139	32

Minimum		Q1		Median		Q3		Maximum		Mean		Std Dev	
H	N/H	H	N/H	H	N/H	H	N/H	H	N/H	H	N/H	H	N/H
0	0	350	75	650	245	1373	536	10088	11500	1034	695	1194	2003

Radiographic Exams

Estimated number of ultrasonography exams
performed each month at all facilities

Number of Procedures	Frequency		Percent		Cum Freq	
	H	N/H	H	N/H	H	N/H
<200	24	6	17.1	18.7	24	6
200-399	36	15	25.7	46.8	60	21
400-699	26	4	18.6	12.5	86	25
700-999	22	5	15.7	15.6	108	30
1000-1500	22	0	15.7	0	130	30
>1500	10	2	7.1	6.3	140	32

Minimum		Q1		Median		Q3		Maximum		Mean		Std Dev	
H	N/H	H	N/H	H	N/H	H	N/H	H	N/H	H	N/H	H	N/H
0	9	250	200	500	281	901	488	6622	5200	682	547	758	928

Estimated number of dental exams
performed each month at all facilities

Number of Procedures	Frequency		Percent		Cum Freq	
	H	N/H	H	N/H	H	N/H
0	88	22	76.5	95.7	88	22
1-5	10	0	8.7	0	98	22
6-10	5	0	4.3	0	103	22
11-20	5	0	4.3	0	108	22
>20	7	1	6.1	4.3	115	23

Minimum		Q1		Median		Q3		Maximum		Mean		Std Dev	
H	N/H	H	N/H	H	N/H	H	N/H	H	N/H	H	N/H	H	N/H
0	0	0	0	0	0	0	0	215	100	6	4	24	21

Radiographic Exams

Estimated number of mobile radiographic exams performed each month at all facilities

Number of Procedures	Frequency		Percent		Cum Freq	
	H	N/H	H	N/H	H	N/H
0	96	0	89.0	0	96	0
1-10	1	0	3.7	0	97	0
11-20	3	0	2.75	0	100	0
21-50	3	0	0.9	0	103	0
>50	6	0	1.8	0	109	0

Minimum		Q1		Median		Q3		Maximum		Mean		Std Dev	
H	N/H	H	N/H	H	N/H	H	N/H	H	N/H	H	N/H	H	N/H
0	0	0	0	0	0	0	0	200	0	8	0	28	0

Estimated number of nuclear medicine exams performed each month at all facilities

Number of Procedures	Frequency		Percent		Cum Freq	
	H	N/H	H	N/H	H	N/H
<50	19	14	14.0	58.3	19	14
50-149	30	2	22.0	8.3	49	16
150-299	35	5	25.7	20.8	84	21
300-700	36	2	26.5	8.3	120	23
>700	16	1	11.8	4.2	136	24

Minimum		Q1		Median		Q3		Maximum		Mean		Std Dev	
H	N/H	H	N/H	H	N/H	H	N/H	H	N/H	H	N/H	H	N/H
0	0	120	0	240	26	456	216	4097	3500	368	227	500	706

Radiographic Exams

Estimated number of bone density
exams performed each month at all facilities

Number of Procedures	Frequency		Percent		Cum Freq	
	H	N/H	H	N/H	H	N/H
<30	54	8	44.2	26.7	54	8
30-65	29	6	23.8	20	83	14
66-100	15	4	12.3	13.3	98	18
101-200	16	8	13.1	26.7	114	26
>200	8	4	6.5	13.3	122	30

Minimum		Q1		Median		Q3		Maximum		Mean		Std Dev	
H	N/H	H	N/H	H	N/H	H	N/H	H	N/H	H	N/H	H	N/H
0	0	0	28	36	74	90	150	302	2128	59	162	70	382

X-Ray Equipment

Current and projected type of radiographic/ fluoroscopic systems
in use at facility for performing upper G.I. exams

Type of Equipment	Frequency		Percent		Cum Freq	
	H	N/H	H	N/H	H	N/H
Currently use film based/not planning to convert to digital	22	11	15.3	32.3	22	11
Currently use film based/plan to convert to digital	19	7	13.2	20.6	41	18
Currently use both digital and film based	55	5	38.2	14.7	96	23
Currently use only digital	48	11	33.3	32.3	144	34

Number of general purpose radiographic/fluoroscopic (R/F)
systems in use at facility

Number of General Purpose R/F	Frequency		Percent		Cum Freq	
	H	N/H	H	N/H	H	N/H
0-2	77	26	53.4	78.8	77	26
3-5	42	5	29.2	15.1	119	31
6-10	19	2	13.2	6.1	138	33
11-20	5	0	3.5	0	143	33
>20	1	0	0.7	0	144	33

Minimum		Q1		Median		Q3		Maximum		Mean		Std Dev	
H	N/H	H	N/H	H	N/H	H	N/H	H	N/H	H	N/H	H	N/H
1	1	2	1	1	1	4	2	21	9	3.7	2	3.7	1.8

X-Ray Equipment

Number of dedicated angiographic units in use at facility

Number of Dedicated Angiographic Units	Frequency		Percent		Cum Freq	
	H	N/H	H	N/H	H	N/H
0	53	24	40.2	92.3	53	24
1	60	2	45.5	7.7	113	26
2	9	0	6.8	0	122	26
3-4	9	0	6.8	0	131	26
5 or more	1	0	0.8	0	132	26

Minimum		Q1		Median		Q3		Maximum		Mean		Std Dev	
H	N/H	H	N/H	H	N/H	H	N/H	H	N/H	H	N/H	H	N/H
0	0	0	0	1	0	1	0	5	1	0.8	0.1	0.96	0.3

Number of dedicated electrophysiology units in use at facility

Number of Dedicated Electrophysiology Units	Frequency		Percent		Cum Freq	
	H	N/H	H	N/H	H	N/H
0	104	0	88.1	0	104	0
1	11	0	9.3	0	115	0
2	3	0	2.5	0	118	0
>2	0	0	0	0	118	0

Minimum		Q1		Median		Q3		Maximum		Mean		Std Dev	
H	N/H	H	N/H	H	N/H	H	N/H	H	N/H	H	N/H	H	N/H
0	0	0	0	0	0	0	0	2	0	0.1	0	0.4	0

X-Ray Equipment

Number of dedicated interventional radiology units in use at facility

Number of Dedicated Interventional Units	Frequency		Percent		Cum Freq	
	H	N/H	H	N/H	H	N/H
0	53	23	41.1	92	53	23
1	43	2	33.3	8	96	25
2	11	0	8.5	0	107	25
3-4	14	0	10.9	0	121	25
5 or more	8	0	6.2	0	129	25

Minimum		Q1		Median		Q3		Maximum		Mean		Std Dev	
H	N/H	H	N/H	H	N/H	H	N/H	H	N/H	H	N/H	H	N/H
0	0	0	0	1	0	2	0	50	1	1.5	0.1	4.6	0.3

Number of mobile c-arm units in use at facility

Number of Mobile C-Arm Units	Frequency		Percent		Cum Freq	
	H	N/H	H	N/H	H	N/H
0-2	66	26	46.8	96.3	66	26
3-5	58	1	41.1	3.7	124	27
6-10	13	0	9.2	0	137	27
11-20	4	0	2.8	0	141	27
>20	0	0	0	0	141	27

Minimum		Q1		Median		Q3		Maximum		Mean		Std Dev	
H	N/H	H	N/H	H	N/H	H	N/H	H	N/H	H	N/H	H	N/H
0	0	1	0	3	0.2	4	0	16	3	3	0.2	2.8	0.7

Physics Quality Assurance Testing

Frequency of physics testing for x-ray units performing
upper G.I. fluoroscopy that were surveyed
as part of the NEXT study

Physics Quality Assurance Testing	Frequency		Percent		Cum Freq	
	H	N/H	H	N/H	H	N/H
Weekly	0	0	0	0	0	0
Monthly	0	0	0	0	0	0
Quarterly	1	0	0.7	0	1	0
Annually	128	32	92.1	94.1	129	32
Semi-Annually	6	0	4.3	0	135	32
Never	0	0	0	0	135	32
As Required	4	1	2.9	2.9	139	33
Unknown	0	1	0	2.9	139	34

Testing typically performed as part of the physics survey *

Physics Testing Performed	Frequency		Percent	
	H	N/H	H	N/H
Fluoroscopic Collimation	138	29	99.3	85.3
Spot Film Collimation	123	25	88.5	73.5
kVp Accuracy	138	27	99.3	79.4
X-ray Beam Quality (HVL)	141	29	100	85.3
Spot Film AEC Performance	109	26	78.4	76.5
Tube Output (mR/mAs)	128	26	92.1	76.5
Tube Output Linearity	123	25	88.5	73.5
Tube Output Reproducibility	111	23	79.9	67.6
Estimate of Patient Dose	133	28	95.7	82.4
Dose Rate for High Dose Mode	97	13	69.8	38.2
Fluoroscopic Contrast Resolution	123	25	88.5	73.5
Fluoroscopic Spatial Resolution	113	21	81.3	61.8
I/I Input Dose Rate	80	18	57.5	52.9
Softcopy Imaging Display QC	48	6	34.5	17.6

* Percentages appearing in columns 3 & 4 are obtained by dividing the numbers in columns 1 & 2 by the number of facilities that responded to the question about how often physics QC testing was done on the specific unit that was surveyed (see above table)

Questions Regarding Interventional Procedures

Does the facility have a user credentialing program?

Yes		No	
H	N/H	H	N/H
30	5	86	16

Is the user credentialing program provided in-house or under contract?

Credentialing Program	H	N/H
In-House	27	5
Contract	2	0

Does the facility have a patient dose monitoring program in place?

Yes		No	
H	N/H	H	N/H
44	6	67	12

Provide a brief description of the facility patient dose monitoring program
Specific answers received from hospitals

All radiographic procedures are included-general procedure to special procedures. Patient radiographic doses are reviewed by physicist annually.
Selective fetus dose-paperwork given to the physicist with fetus dose measurements for calculation.
High fluoroscopic on time is monitored and anything over 60 minutes is reported to the RSO and a dose determination is done by the physicist.
Recording of doses
Fluoro time is documented for each case
Fluoro exposure over 60 minutes is documented
All fluoro times are monitored on all exams. Report is run quarterly and reviewed at radiation safety meeting.
Patient fluoro time is recorded
All fluoro times are recorded. Analysis for exposure times greater than 40 minutes.

Brief description of the facility patient dose monitoring program (Continued)

Film badge kept outside of room.
Track fluoro times. Question 8 (credentialing program) they are in the progress of setting up.
Fluoroscopy times are recorded on all patients.
Fluoro times are recorded.
Track fluoro times. Question 8 (credentialing program) in progress.
For these exams:AP Abdomen, Head, Arm,PA Chest, and Leg.
Question 13 (patient follow-up) in progress
All procedures that require fluoro are logged into our RIS and we document (log-in) the fluoro time.
Fluoro time monitoring and recording
All areas enter information in the hospital billing system. The exam data entry, the major areas, cath lab and special procedures, utilize computer archiving WIT and STAR (archiving systems/CD burner).
Monitor fluoro time per patient
The only procedure done is that the facility sends Dr. Patel (Physicist) information about the patient and exam that the(y) did.
Monitor the fluoro time used.
Fluoro time is noted for each pt. And the new angion room keeps a pt. profile of skin dose for each pt.
Pt dose/time.
Monitor and document the time of fluoro per patient.
After each procedure, fluoro time is recorded for each patient.
Medical Physicist discussed with staff type of studies performed and typical techniques. Abdomen, pelvis, skull chest, hand, wrist and ankle.
Hosp. Fluoro patient follow-up policy is initiated if machine specific action levels are exceeded. ie., fluoro time or cine time. Implementation of this will be completed by end of August 2003 after specific levels are developed.
Fluoro time log—fluoro procedures
Length of time for each fluoro procedure is recorded
Educational handout on fluoro exposures and skin injuries with post test required. All fluoro is low risk, short times and no complex procedures.
Per Radiation Safety Committee, procedure for prolonged fluoro exposure monitoring: criterion is 60 min. exposure in single episode.
Document total fluoro time
Timer on the fluoro unit resets every 4.5 min
In house rso can calculate patient dose upon request.
No dose monitoring program for g.i.
Dose 200 rad limit, reported to physicist
All Cath lab fluoro imaging.
Manual—Soon to have integrated system.
We record fluoro time
The attached policy states that time and technique factors should be monitored and recorded for large doses of radiation.

Brief description of the facility patient dose monitoring program (Continued)

After speaking with _____ (manager), she stated that they do not have an interventional procedure at this facility.
Fluoro time written in log book. Rad monitor in control booth
There are no interventional procedures...all diagnostic

If the Joint Commission for the Accreditation of Health Care Organizations should incorporate fluoroscopically induced skin injuries into its Sentinel Event program, does the facility have a policy and procedure in place to conduct a causal analysis of this type of event?

Yes		No	
H	N/H	H	N/H
55	5	60	14

Does the patient consent form used by the facility for interventional procedures address radiation exposure and potential skin injuries?

Yes		No	
H	N/H	H	N/H
6	1	101	15

Is it standard procedure to question patients regarding their history of medical imaging exposure?

Yes		No	
H	N/H	H	N/H
17	6	98	15

Does the facility conduct any follow up on patients relating to possible radiation induced injuries that could result from fluoroscopic procedures?

Yes		No	
H	N/H	H	N/H
28	4	85	16

What image intensifier field size is most typically used when fluoroscopy is employed during interventional procedures?

Image Intensifier Field Size (inches)	Frequency		Percent		Cum Freq	
	H	N/H	H	N/H	H	N/H
6	4	1	4.6	12.5	4	1
9	26	4	29.9	50	30	5
12	23	2	26.4	25	53	7
16	17	0	19.5	0	70	7
Other	17	1	19.5	12.5	87	8

APPENDIX

PROTOCOL FOR 2003 NEXT SURVEY OF FLUOROSCOPIC X-RAY SYSTEMS



**NATIONWIDE EVALUATION
OF X-RAY TRENDS (NEXT)**

**PROTOCOL FOR
2003 SURVEY OF FLUOROSCOPIC
X-RAY SYSTEMS**

September 2009

Published by
Conference of Radiation Control Program Directors, Inc.
www.crcpd.org

[Inside front cover-intentionally blank.]

**Nationwide Evaluation of X-ray Trends (NEXT)
Protocol for
2003 Survey of Fluoroscopic X-Ray Systems**

Prepared by

Richard V. Kaczmarek and David C. Spelic
Food and Drug Administration (FDA)
Center for Devices and Radiological Health (CDRH)

in association with

Conference of Radiation Control Program Directors, Inc.'s
Committee on Nationwide Evaluation of X-ray Trends (H-4)

and

American College of Radiology

Committee on Nationwide Evaluation of X-ray Trends (H-4)

Members

Mary Ann Spohrer, (Chair, Illinois), Robert Scott (Pennsylvania),
Bruce Matkovich (Michigan), Warren Freier (North Dakota), Jay Nakasone (Hawaii)

FDA Liaison

John McCrohan (FDA/CDRH)

Resource Individuals

Michael Leal (FDA/ORR), Jan Martensen (American Chiropractic College of
Radiology), Albert Moyal (FDA/CDRH), David Spelic (FDA/CDRH),
Richard Kaczmarek (FDA/CDRH), Keith Strauss (American Association of
Physicists in Medicine)

Advisors

Jennifer Elee (Louisiana), Aaron Gantt (South Carolina), Edward Gloor (California),
Beverly Hall (North Carolina), Josip Nosil (Capital Health Region, BC, Canada),
Philip Thoma (Florida), Diana Wozniak (Connecticut),
Terry Yoshizumi (Affiliate – Duke Univ.), Jack Ferruolo (Rhode Island)

September 2009

Published by
Office of Executive Director
Conference of Radiation Control Program Directors, Inc.
1030 Burlington Lane, Suite 4B
Frankfort, Kentucky 40601
www.crcpd.org

This publication was supported in part by grant number FD-U-000005 through a cooperative agreement with the U.S. Food and Drug Administration. Use of the information contained in this document is at the discretion and sole responsibility of the user. This document was prepared by FDA staff in association with a working group of the Conference of Radiation Control Program Directors, Inc. (CRCPD) and accepted by the CRCPD Board of Directors for publication. The contents do not necessarily represent the views of the membership of the CRCPD, of FDA, or of any other federal agency supporting this work. The mention of commercial products, their sources, or their use in connection with material reported herein is not to be construed as either an actual or implied endorsement of such products by the CRCPD or any federal agency.

FOREWORD

The Conference of Radiation Control Program Directors, Inc. (CRCPD) is an organization made up of the radiation control programs in each of the 50 States, the District of Columbia, and Puerto Rico, and of individuals, regardless of employer affiliation, with an interest in radiation protection. The primary purpose and goal of CRCPD is to assist its members in their efforts to protect the public, radiation workers, and patients from unnecessary radiation exposure. CRCPD also provides a forum for centralized communication on radiation protection matters between the States and the Federal government, and between the individual States.

One method of providing assistance to the States, as well as to other interested parties, is through technical and administrative publications. Most technical publications of CRCPD are written by various committees, task forces or special working groups. Most administrative publications are written by staff of the Office of Executive Director (OED).

CRCPD's mission is "to promote consistency in addressing and resolving radiation protection issues, to encourage high standards of quality in radiation protection programs, and to provide leadership in radiation safety and education."

This particular publication, *Nationwide Evaluation of X-ray Trends (NEXT) Protocol for 2003 Survey of Fluoroscopic X-Ray Systems*, contains the survey procedures developed to collect information for a population-representative reference database documenting diagnostic imaging with x-ray fluoroscopy.



Adela Salame-Alfie, Chairperson
Conference of Radiation Control
Program Directors, Inc.

[This page is intentionally blank.]

PREFACE

This document contains the survey procedures developed to collect certain information for a population-representative reference database documenting diagnostic imaging with x-ray fluoroscopy. The 2003 NEXT fluoroscopy survey consisted of a site visit by trained state radiation personnel, and a facility questionnaire.

The protocol asked for information about the particular units being surveyed and the technique factors that the facility normally used for fluoroscopic procedures. The surveyor was to measure x-ray exposure and obtain some data relating to image quality and film processing.

Surveyors were requested to elicit responses to the [Facility Questionnaire](#) from facility staff that were familiar with the site's practice of diagnostic imaging with fluoroscopy.

The following states participated in this survey:

Arkansas	Maine	Pennsylvania
Arizona	Michigan	Rhode Island
California	Mississippi	South Carolina
Idaho	Nebraska	Texas
Illinois	New Jersey	Utah
Iowa	North Carolina	Virginia
Kentucky	North Dakota	Washington
Louisiana	Ohio	Wisconsin
Massachusetts	Oregon	

We recognize the voluntary nature of participating in this survey by the various state radiation control programs, and we appreciate these efforts. We also recognize the American College of Radiology for their generous financial support for surveyor travel to training.

Richard Kaczmarek

Richard Kaczmarek
Food and Drug Administration
Division of Mammography Quality and Radiation Programs

Mary Ann Spohrer

Mary Ann Spohrer, Chairperson
Committee on Nationwide Evaluation
of X-ray Trends

[This page is intentionally blank.]

ABSTRACT

Kaczmarek, Richard, Spelic, David C., CRCPD Committee on Nationwide Evaluation of X-ray Trends, *Nationwide Evaluation of X-ray Trends (NEXT) Protocol for 2003 Survey of Fluoroscopic X-Ray Systems*, CRCPD Publication E-09-4 (September 2009) (39 pp.)

This survey protocol has been developed to obtain certain information concerning diagnostic imaging with x-ray fluoroscopy. It describes the information to be gathered and the methods for obtaining it. The facilities to be surveyed are chosen randomly from a nationwide list. Each state is given a list of facilities to survey using these procedures. The information requested is different in some respects from that which many States normally collect during their visits to x-ray facilities.

[This page is intentionally blank.]

CONTENTS

Foreword.....	55
Preface.....	57
Abstract.....	59
Introduction.....	62
A. General Survey Information – Facility Identification.....	66
B. Equipment Data.....	69
C. Fluoroscopy Technique Data	71
D. Spot Film Data	72
E. Instructions for General Radiographic/Fluoroscopic Survey Procedure.....	73
F. Radiographic/Fluoroscopic HVL & Image Evaluation	84
G. Imaging of Test Tool & Determining Target-Table Top Distance.....	91
H. Processor Data.....	95

APPENDIX

Facility Questionnaire.....	98
-----------------------------	----

FIGURES

NEXT Fluoroscopy Phantom.....	65
Figure 1. Set-up configuration for under-table units	74
Figure 2. Set-up configuration for over-table units	75
Figure 3. Placement of copper and lead sheets for under-table units	77
Figure 4. Placement of copper and lead sheets for over-table units	78
Figure 5. Placement of aluminum for HVL determination on under-table units.....	86
Figure 6. Positioning 4.5 mm Aluminum for the HVL procedure, under-table units.....	87
Figure 7. Set-up for fluoroscopic and radiographic high-low contrast procedure for under-table units	93
Figure 8. Over-table units: Positioning of test tool and target-table top distance measurement	93
Figure 9. Fluoroscopic test tool—view of embedded test objects	94

INTRODUCTION

This survey protocol has been developed to obtain certain information concerning diagnostic imaging with x-ray fluoroscopy. It describes the information to be gathered and the methods for obtaining it. The facilities to be surveyed are chosen randomly from a nationwide list. Each State is given a list of facilities to survey using these procedures. The information requested is different in some respects from that which many States normally collect during their visits to x-ray facilities.

Through the selection of a national sample and the use of a complete protocol by all participants for this small number of surveys, the total amount of the data collected can be reduced. For success and completeness of the project, every facility in the sample should be surveyed. All data elements should be acquired by following the guidelines indicated.

The protocol asks for information about the particular units being surveyed and the technique factors that the facility normally uses for fluoroscopic procedures. The surveyor will measure x-ray exposure and obtain some data relating to image quality and film processing. In each facility, the unit to be surveyed should be the one that is most frequently used to perform the procedure. You should select the room where the facility conducts the majority of their upper G.I. studies.

It is preferred that the survey form be completed electronically. However, if it is done on paper we recommend using pencil so that errors are more easily corrected. Crossing out errors and writing outside boxes is more likely to result in mistakes when entering data from paper forms. Groups of boxes for a single entry **SHOULD** be filled with leading or trailing zeros as appropriate unless indicated otherwise in this protocol. For example, if an exposure measurement of 78.0 mR is obtained, it should be coded 0078.0.

About this survey protocol

This survey has been modified somewhat from that used for the 1996 survey. A separate questionnaire is now provided for the facilities that perform G.I. fluoroscopy. This form requests information regarding their quality assurance and quality control programs as well as further details regarding their equipment and procedures. We ask that you mail or fax this separate form to the facility prior to your arrival. Advance transmission will give the facility personnel time to complete the form and also allows you to review and clarify their responses prior to leaving the facility after your survey.

Your state facility sample

The number of facilities you are asked to survey is based on your state's population relative to the rest of the U.S. You will receive a list of facilities you will be asked to survey, and you will also be provided with alternate facilities in the event the primary facility does not wish or is not able to participate. Please do not select the alternates over the primary facility merely because it

is convenient or near a desirable location because biased selections may compromise the integrity of the random sample. However, we do understand that the finite resources and time of your state program may preclude you from traveling to some facilities. If you have any questions regarding your facility sample, contact Rick Kaczmarek or David Spelic.

What you should do before starting your surveys

- Review your facility sample: you may be aware of facilities that are no longer in operation, or there may be locations you cannot visit. Please advise us as soon as possible regarding these matters.
- Check the calibration of your MDH survey meter and probe. They should be calibrated **BY CDRH** annually. If you need to make arrangements for calibration, contact Rick Kaczmarek or David Spelic.

NOTE: It is acceptable to use an MQSA-calibrated sensitometer and/or densitometer.

- Check the calibration of your sensitometer and densitometer. These instruments also should be calibrated **by CDRH** annually. Contact Stephanie Belella or Dave Spelic if they are near the end of their current calibration period.
- The fluoroscopy phantom requires minimal assembly.

What to bring with you to the survey site

You will need the following equipment and supplies for each survey:

1. CDRH upper gastrointestinal fluoroscopy phantom
2. CDRH image-quality test-tool
3. Calibrated MDH model 1015 or 1515 survey meter with calibrated 10X5-6 probe
4. Aluminum filters for HVL determination (2.0 mm and 1.0 mm increments)
5. Calibrated sensitometer and densitometer
6. One box of STEP test control film and appropriate STEP worksheet
7. Fog folder or other similar darkroom fog test tool
8. Protocol and survey form (along with facility questionnaire, if appropriate)
9. NEXT tri-folds for the facility

Your NEXT fluoroscopy phantom set should include the following items:

1. One fluoroscopy phantom body

2. One brass mounting plate for attaching the MDH probe
3. One plastic bolt for attaching the mounting plate to the phantom body
4. One plastic side plate for supporting the remaining end of the phantom
5. One fluoroscopy image quality test tool (referred to as the 'hockey puck')
6. One copper plate (supplied with the phantom)
7. One lead sheet (supplied with the phantom)
8. Gray shipping case with wheels

What items you are asked to return to CDRH

In addition to the paper survey form, you will be provided an electronic spreadsheet with which to record your data. You will be provided one spreadsheet file for each facility you are asked to survey. The paper forms are actually printed copies of the Excel spreadsheet files; hence you may print paper copies from the provided disk(s).

Please return your survey materials to the following address:

At the time of the survey:

Attention: Rick Kaczmarek
 David Spelic
 1350 Piccard Drive
 HFZ-240
 Rockville, MD 20850

In 2009 CDRH moved to:

10903 New Hampshire Avenue
 W066 – Mail Drop 4521
 Silver Spring, MD 20903-0002

The telephone number is 301/796-5710

Contact Information:

At the time of the survey:

Richard Kaczmarek
 301-827-1230
rvk@cdrh.fda.gov

David C. Spelic
 301-594-0865
dcs@cdrh.fda.gov

In 2009, when this document was published:

Kaczmarek, Richard V. [Richard.Kaczmarek@fda.hhs.gov]
 Spelic, David C. [David.Spelic@fda.hhs.gov]

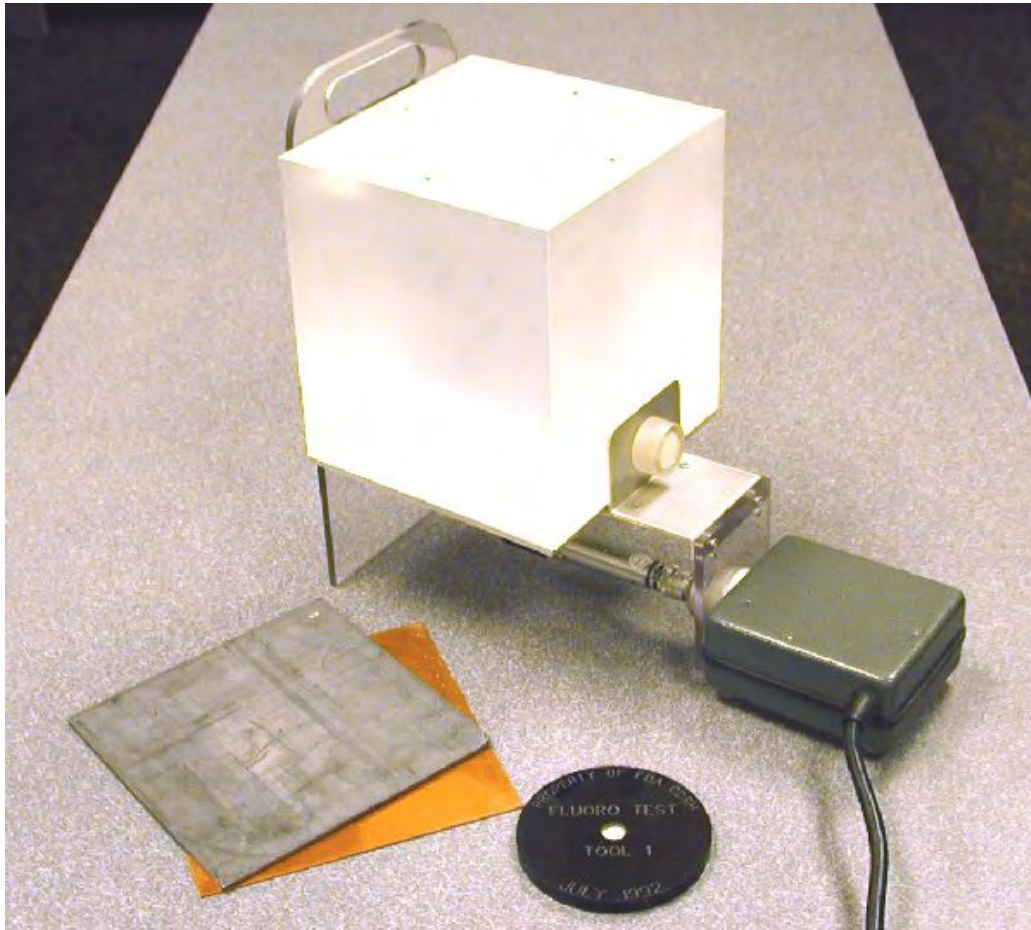

The NEXT Fluoroscopy Phantom

For each survey, you are asked to return the following to CDRH:

- Completed paper survey form (*MAKE A PHOTOCOPY OF YOUR ORIGINAL*) or spreadsheet disk if used
- Facility questionnaire
- Phantom film(s)
- Fog film(s)
- STEP film and worksheet
- HVL graph

We appreciate your participation!

A. GENERAL SURVEY INFORMATION - FACILITY IDENTIFICATION

- 1. Facility Name:** Enter the name of the hospital or x-ray facility in the space provided. If the x-ray system is located in a private office, use the name of the physician.
- 2. Person Interviewed:** Write the initials, last name and title or position of the person who provided the information regarding the system.
- 3. State Code:** Use the appropriate two letter abbreviation (postal codes) in the space provided.

STATE CODE

EXAMPLE: | V | A |

- 4. Facility Identification Number:** Enter the facility identification number. This is an identification number assigned by your State program. Space is provided for ten (10) characters. If your identification number has less than ten (10) characters, enter it with **LEADING ZEROS** as appropriate. The number may **NOT** be totally **BLANK**. Letters or numbers may be used in any combination. Hyphens (-) are acceptable but **NO OTHER SYMBOLS ARE ALLOWED**.

FACILITY IDENTIFICATION NUMBER

EXAMPLE: | 2 | 3 | 4 | 5 | 6 | B | 7 | C | 3 | 2 |

or if less than 10 digits: | 0 | 0 | 0 | 0 | 0 | 7 | F | L | 8 | 4 |

- 5. Date of Survey:** Enter the date on which the survey was done. Note the boxes are for month, day, and year, in that order. Always use two digit numbers. For example July 26, 2003 would be coded:

DATE OF SURVEY

EXAMPLE: | 0 | 7 | 2 | 6 | 0 | 3 |

MO DA YR

- 6. Room Number:** Enter the room or tube number here. This five digit number is to be assigned by the surveyor in a manner such that no two units within a given facility have the same number. Letters and numbers may be used in any combination. Hyphens (-) are acceptable but no other symbols are allowed; leading blanks are acceptable. It may be helpful to further identify the unit in the comments section by giving information pertaining to the make and type of x-ray machine so that if the facility is re-surveyed, the same number can be assigned to

the same unit. One method might be to use the last five digits of the tube's serial number for ease of identification.

ROOM NUMBER

EXAMPLE: | 2 | B | - | 8 | 5 |

7. **Type of Facility:** Determine the **Type of Facility** from the list below and enter the corresponding code in boxes. If code 99 (meaning "other") is used, please specify the type of facility under Surveyor's Comments.

TYPE OF FACILITY

EXAMPLE: | 0 | 1 |

The following codes and definitions apply to **Type of Facility** for the NEXT surveys. In selecting codes for facilities where more than one code would apply, use the first applicable code listed. For example, a medical school hospital could be coded "02 hospital" or "05 school" under Type of Facility. The proper code will be "02 hospital" since it appears first on the list.

TYPE OF FACILITY CODES

- 01 = Private Practice:** An individual practitioner or a group of practitioners engaged in the same specialty. This includes a group of general practitioners. **If 01 is used, then Type of Practice must also be coded.**
- 02 = Hospital:** A facility that has beds for overnight care of patients.
- 03 = Multiple Specialty Practice:** A group of practitioners having different specialties. This includes school infirmaries, clinics, HMO's, DMS's, etc.
- 04 = Mobile Unit:** An x-ray machine transported by motor vehicle.
- 05 = School:** An educational institution. School infirmaries or clinics are coded 03. Medical school hospitals are coded 02.
- 06 = Private Laboratory:** A commercial facility that takes diagnostic radiographs by prescription but is not involved in film interpretation.
- 07 = Health Agency:** Voluntary and governmental health agencies that do not fall under any of the above categories.
- 08 = Industry:** A plant dispensary or first aid station.
- 09 = Nursing Home:** A facility with provisions for long-term care of patients.
- 10 = Breast Clinic:** A facility specializing in mammography and breast disease.
- 11 = Hospital Satellite Facility:** A facility affiliated with a hospital or medical center that is physically removed from the hospital/ medical facility (i.e., different mailing address)

99 = Other: Please specify in comments section.

- 8. Facility Specialty Code:** Use this code listing if the facility specializes in a certain type of medical practice (e.g., pediatrics). If the Type of Facility (see above) is coded "**01**" **Private Practice**, then determine the appropriate facility specialty code from the list below. If the facility is not coded "01" Private Practice, leave the Facility Specialty Code boxes blank.

LIST OF FACILITY SPECIALTY CODES

01 = DENTAL (EXCEPT ORTHODONTICS)	17 = ENDOCRINOLOGY
02 = ORTHODONTICS	18 = GERIATRICS
03 = MEDICAL G.P.	19 = HEMATOLOGY
04 = RADIOLOGY	20 = IMMUNOLOGY
05 = INTERNAL MEDICINE	21 = INFECTIOUS DISEASES
06 = SURGERY	22 = NEPHROLOGY
07 = UROLOGY	23 = NEUROLOGY
08 = PEDIATRICS	24 = NUCLEAR MEDICINE
09 = ORTHOPEDICS	25 = ONCOLOGY
10 = GASTROENTEROLOGY	26 = OPHTHALMOLOGY
11 = CHIROPRACTIC	27 = OTOLARYNGOLOGY
12 = PODIATRY	28 = PHYSICAL MEDICINE
13 = OSTEOPATHY	29 = PULMONARY MEDICINE
14 = OB/GYN	30 = EMERGENCY MEDICINE
15 = CARDIOLOGY	99 = OTHER
16 = ELECTROPHYSIOLOGY	

FACILITY SPECIALTY CODES

EXAMPLE: | 0 | 3 |

- 9. Survey Unit Workload:** Enter the number of adult upper gastro-intestinal fluoroscopy examinations normally performed per week **with this fluoro unit**. The actual workload or an estimate should be entered, with a minimum of one procedure per week. Take some time to assure this value is as reliable as possible. The workload refers only to the examination that is being surveyed, and should not include any other examinations. Please indicate in the comments section of the survey form if the unit surveyed is not the one on which the majority of upper G.I. fluoro studies done at the facility are performed (or if the facility regularly performs these exams on two or more units).

FLUORO UNIT WEEKLY
UPPER G/I. WORKLOAD (exams/week)

EXAMPLE: | 0 | 0 | 5 |

10. **Facility Weekly Workload:** Enter the number of adult upper gastro-intestinal fluoroscopy examinations normally performed per week **at the entire facility**. As in the previous question, no other procedures should be included, and either the actual workload or an estimate should be entered. As an example, a facility may have two fluoroscopy rooms where upper G.I. exams are done, with the workload about evenly split. In this case the answer given here would be twice what is recorded in question nine.

FACILITY WEEKLY
UPPER G/I. WORKLOAD

EXAMPLE: | 0 | 1 | 0 |

B. EQUIPMENT DATA

1. **X-Ray Unit Control Manufacturer:** Determine the manufacturer of the x-ray unit and write the name in the space provided. Determine the code for the manufacturer from the list in Supplement Section B and enter the appropriate code in the boxes.

X-RAY CONTROL
MANUFACTURER

EXAMPLE: | G | E | C | O |

2. **X-Ray Unit Control Year of Manufacture:** Determine the Year of manufacturer of the x-ray control unit and enter the last two digits of the year in the boxes provided e.g. 1995 would be entered as 95.

YEAR OF MANUFACTURE

EXAMPLE: | 8 | 5 |

3. **Type of Equipment:** Determine the type of equipment from the code list and enter the corresponding code.

TYPE OF EQUIPMENT CODES

- 1** = Under-table fluoroscopic **NON IMAGE INTENSIFIED**
2 = Under-table fluoroscopic **IMAGE INTENSIFIED WITHOUT TV Monitor**
3 = Under-table fluoroscopic **IMAGE INTENSIFIED WITH TV Monitor**
4 = Over-table fluoroscopic **IMAGE INTENSIFIED** (includes special procedures, cardiac catheterization, bi-plane, etc.)
5 = Mobile C-Arm

TYPE OF EQUIPMENT

EXAMPLE: | 1 |

4. **Contrast:** Determine the type of contrast, single (e.g., barium) or double (e.g., barium and effervescence [air]), and which technique, single or double contrast, is most frequently used for the examination being surveyed. Select the code from the following list and enter the appropriate code in the box.

CONTRAST CODES

- A = Only** - single (contrast)
B = Only - double (contrast & effervescence [air])
C = Both - radiopaque contrast most frequently used
D = Both - effervescence (air) most frequently used
E = Both - approximately **Equal use**
F = None

CONTRAST

EXAMPLE: | A |

5. **Image Intensifier (I.I.) Field Size:** There are several image intensifier (I.I.) field sizes for doing fluoroscopic examinations, i.e., field sizes such as 4", 6", 9" 12", etc. Determine which I.I. **field size is normally used for the examination being surveyed** and enter the value in the box. Indicate the units i.e., "IN" = inches or "CM" = centimeters.

I.I. FIELD
SIZE UNITS

EXAMPLE: | 0 | 9 | | I | N |

6. **Grid Used for Fluoroscopy:** Determine if a grid is used routinely for the *fluoroscopic* examination. This may be a separate fluoroscopy grid mounted on the II, or the spot film grid may be used. Indicate which type of grid, if any, is used by placing an 'X' in the appropriate box as shown below.

FLUOROSCOPY GRID

<u>EXAMPLE:</u>	<u>SPOT FILM</u>	<u>II GRID</u>	<u>NO GRID</u>
		X	

C. FLUOROSCOPY TECHNIQUE DATA

- 1. High-Level Control (also called Boost Mode):** Some fluoroscopic units are equipped with a high-level control option. This control requires positive action by the user to activate and permits the unit to exceed the 10 R/min limitation. Determine from the operator if this unit has the High-Level Control option and indicate "YES" or "NO" by marking the appropriate box. **HINT:** If the unit does not have a high-level mode, draw a line through those sections of the data form that are for high level. This will avoid confusion during the data collection.

HIGH LEVEL CONTROL

EXAMPLE: YES NO

- 2. Dose Setting:** Many fluoroscopic systems permit the user to select a dose setting. Indicate the dose setting routinely used for the fluoroscopic examination of a standard patient (the standard "NEXT" patient is a 5'8", 164 pound adult with a 23 cm chest and abdomen). Place an "X" in the appropriate box.

	<u>LOW</u>	<u>MEDIUM</u>	<u>HIGH</u>
	<u>DOSE</u>	<u>DOSE</u>	<u>DOSE</u>
<u>EXAMPLE:</u>	<input type="checkbox"/>	<input checked="" type="checkbox"/>	<input type="checkbox"/>

- 3. Recording Modes:** Most fluoroscopy systems enable the user to record images on film or other modalities. Indicate the type of recording mode **most frequently** used on this unit by selecting a code letter from the following list and entering it in the appropriate box.

CODES FOR RECORDING MODE

S= Spot films that are obtained using a screen/film cassette technique
P= Photo-spot refers to the use of roll or cut film, e.g., 70, 100,105 mm
V= VideoTape Recorder
D= Digital image recording
9 = Some other method is used. Explain in the comments section (e.g., cine)

RECORDING MODE

EXAMPLE: |S|

D. SPOT FILM DATA

THIS INFORMATION NEED NOT BE CAPTURED IF SPOT FILM RADIOGRAPHY IS NOT INDICATED AS THE MOST FREQUENT METHOD OF IMAGE RECORDING (SEE QUESTION 3 OF PREVIOUS SECTION).

1. **Spot Film: Film Brand and Film Type, Screen Brand and Screen Type:** If spot films are routinely taken as a part of the upper GI examination, determine from the operator the screen-film combination used for the spot film. Record this combination on the lines provided, and from the Supplement Sections C and D, determine the film and screen codes, respectively, and enter in the appropriate boxes. **If the SCREEN and FILM codes are NOT on the list, write the COMPLETE NAMES, and the NAME, ADDRESS AND TELEPHONE NUMBER of the supplier in the comments section.**

	FILM <u>BRAND</u>	FILM <u>TYPE</u>
<u>EXAMPLE:</u>	<u> E K C 0 </u> (KODAK)	<u> R 0 C </u> (ORTHO-C)

	SCREEN <u>BRAND</u>	SCREEN <u>TYPE</u>
<u>EXAMPLE:</u>	<u> E K C 0 </u> (KODAK)	<u> L N M </u> (LANEX MED)

2. **Standard Spot Film Procedure:** Indicate the number of each type of spot **film** routinely taken for the upper GI examination. If some other type of spot film is routinely taken, indicate the number and specify the type in the comments section. **This is the number of FILMS, not the number of exposures.**

	<u>1 on 1</u>	<u>2 on 1</u>	<u>4 on 1</u>	<u>OTHER</u>
<u>EXAMPLE:</u>	<u> 0 4 </u>	<u> 0 3 </u>	<u> 0 3 </u>	<u> </u>

3. **Spot Film Grid:** Determine whether a grid is normally used for spot film recording during the upper GI examination, code "G" if grid is used, or "N" for no grid. If unknown, then code the box "X." **THIS IS SPOT FILM GRID USE ONLY- NOT FLUOROSCOPIC.**

	SPOT FILM <u>GRID</u>
<u>EXAMPLE:</u>	<u> G </u>

4. **Spot Film Grid Ratio:** If a grid is normally used for spot film, determine from the operator the grid ratio. The grid ratio should be marked on the grid. If the

unit does not use a grid or the grid ratio is not obtainable, enter XX (do not leave blank).

SPOT FILM
GRID RATIO

EXAMPLE: 1|2 : 1

E. INSTRUCTIONS FOR GENERAL RADIOGRAPHIC/ FLUOROSCOPIC SURVEY PROCEDURE

1. Measurement Set-Up Procedure for Abdominal (Upper G.I) Study - R/F (Under-Table Unit)

- a) Attach the side and MDH probe support to the fluoroscopic phantom as shown in figure 1 below. Place the MDH probe, with the rubber feet resting on the table, in the slot provided in the probe support. The phantom assembly will be upright on the table, with the probe centered under the phantom body.
- b) Have the technologist set up for a routine adult upper G.I. exam, including technique factors, grid position, image intensifier field size, dose mode, etc. Bring the I.I. down until it rests on the top of the phantom side extension. Align the phantom and probe in the center of the field by making fluoroscopic exposures and observing the image of the phantom.
- c) Adjust the collimator until the beam is limited in size to the area indicated by the four (4) lead shot markings on the phantom top. Note: If the selected field size is greater than 9" (23cm), you will have to close the shutters. If you cannot see the four (4) lead shot, the selected I.I. field is less than 9". Lock the I.I. in this position. Once you have set up the phantom, MDH probe and unit, do not move them until you have completed the exposure and exposure rate measurements.

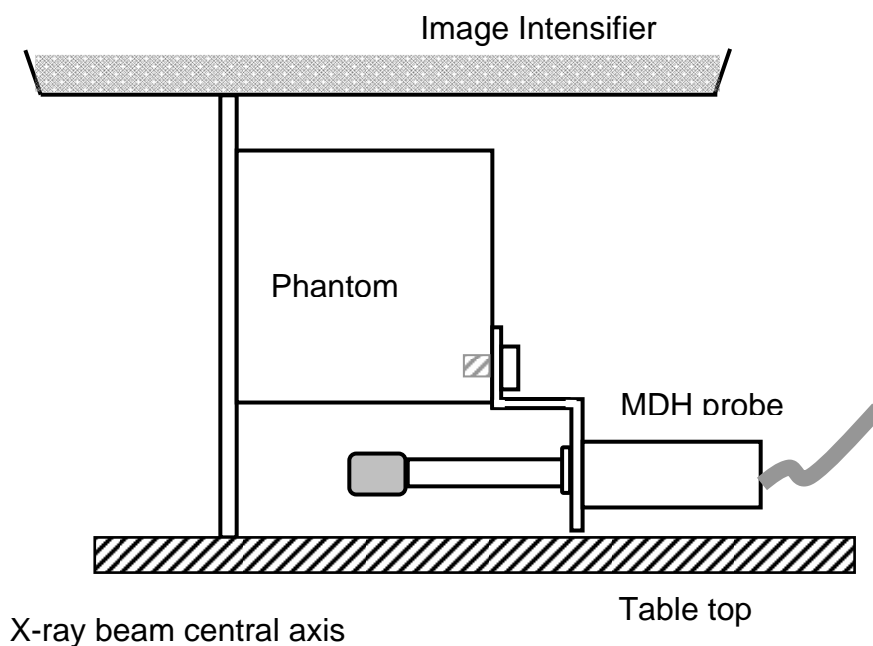

Figure 1. Set-up configuration for under-table units.

2. Measurement Set-Up for Over-Table Units

- a) Attach the MDH probe support to the fluoroscopic phantom- **do not attach the Lexan side**. Place the phantom on the table top with the probe support nearest the tube head as shown (figure 2). Place the MDH probe in the slot provided in the probe support. The probe will be centered over the phantom body.
- b) Select the 9" field size of the image intensifier (I.I.). Have the technologist set up the other parameters pertaining to an adult upper G.I. exam (e.g., x-ray technique). Align the phantom and probe in the center of the field. Note: If you cannot see the four (4) lead shot, the I.I. field is less than 9". (If the 9" field size is not available, select the field size closest to 9" and indicate in the comments section the I.I. field size selected.)

- c) Have the operator position the tube assembly at the normal height for the upper GI examination. Lock the assembly at this height. Once you have set up the phantom, MDH probe and unit, do not move them until you have completed the exposure and exposure rate measurements.
- d) By making fluoroscopic exposures and observing the image of the phantom, adjust the collimator until the beam is limited in size to the area indicated by the four (4) lead shot markings on the phantom (area indicated by the four (4) lead shot located at the center on each edge of the phantom).

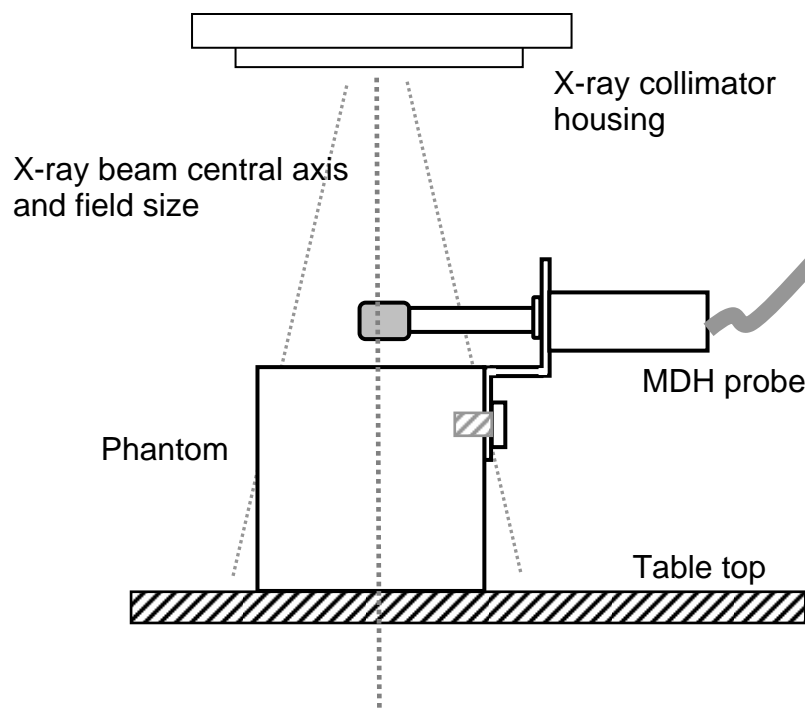

Figure 2. Set-up configuration for over-table units.

3. Fluoroscopic Exposure Rate Data - Abdominal (Upper G.I.) Study For Over-Table AND Under-Table Set-Ups

Fluoroscopic kVp, mA, and MDH Exposure Rate: Set the MDH selector switch to the "EXPOSURE RATE" mode. Without making any changes in the standard patient techniques, with the phantom and MDH probe properly positioned, and the beam collimated to the four markings on the phantom, make an exposure and hold until the meter reading stabilizes. **RECORD THIS EXPOSURE RATE in mR/min as Fluoroscopy Exposure Rate #1.** Record the

fluoroscopic kVp selected as Fluoroscopy kVp #1. If the unit has an mA indicator, read and record the mA value during the exposure as Fluoroscopy mA #1.

	Fluoroscopy EXPOSURE RATE #1 (mR/min)	Fluoro mA #1	Fluoro kVp #1
<u>EXAMPLE:</u>	<u> 0 0 8 0 0 </u>	<u> 0 0 . 2 </u>	<u> 0 9 0 </u>

If the exposure rate is greater than 1 R/min, the values are recorded as 1000 mR/min per R/min. For example, 12 R/min would be coded 12000 mR/min.

Repeat the exposure and record the values for Fluoro Exposure Rate #2, Fluoro mA #2, and Fluoro kVp #2, respectively.

4. Fluoroscopic kVp, mA and MDH Exposure Rate with Copper Filter
For Over-table AND Under-Table Set-Ups

DO NOT make this measurement for MANUAL systems.

Set the MDH selector switch to the "EXPOSURE RATE" mode. Without making any changes in the standard patient techniques, ensure that the phantom and MDH probe are properly positioned, and the beam collimated to the four markings on the phantom. Place the 1 mm sheet of copper on the upper surface of the phantom- see Figures 3 (under-table units) and 4 (over-table units) below. **YOU SHOULD NOT NEED TO MOVE THE PHANTOM!** Begin exposure as above, and hold exposure until you see that the meter reading is steady.

RECORD THIS EXPOSURE RATE AS FLUORO COPPER EXPOSURE RATE #1. Record the selected kVp as Fluoro Copper kVp #1. If the unit has an mA indicator, read and record the mA value during the exposure as Fluoro Copper mA #1. Repeat the exposure a second time, and record the values for Fluoro Copper Exposure Rate #2, Fluoro Copper kVp #2, and Fluoro Copper mA #2, respectively.

	FLUORO COPPER EXPOSURE RATE #1 (mR/min)	FLUORO COPPER mA #1	FLUORO COPPER kVp #1
<u>EXAMPLE:</u>	<u> 0 1 2 0 0 </u>	<u> 0 3 . 0 </u>	<u> 0 9 0 </u>

5. Maximum Fluoroscopic kVp, mA and MDH Exposure Rate with Copper and Lead - For Over-Table AND Under-Table Set-Ups

DO NOT make this measurement for MANUAL systems.

Set the MDH selector switch to the "**EXPOSURE RATE**" mode. Without making any changes in the standard patient techniques, with the phantom and MDH probe properly positioned and the beam collimated to the four markings on the phantom, place the 1 mm sheet of copper and the lead sheet on the upper surface of the phantom (see **figure 3 OR figure 4**). Initiate exposure and hold until the output (meter reading) stabilizes. **RECORD THIS EXPOSURE RATE as Fluoro Maximum-Exposure Rate #1.** Record the selected kVp as Fluoro Maximum-kVp #1. Read and record the mA value during the second exposure as Fluoro Maximum-mA #1. Repeat the exposure and record the values for Fluoro Maximum-Exposure Rate #2, Fluoro Maximum-kVp #2, and Fluoro Maximum-mA #2, respectively.

	FLUORO MAX EXPOSURE RATE #1 (mR/min)	FLUORO MAXIMUM mA #1	FLUORO MAXIMUM kVp #1
EXAMPLE:	1 3 2 0 0	0 5 . 0	1 1 0

REMOVE THE COPPER & LEAD SHEETS FROM THE PHANTOM.

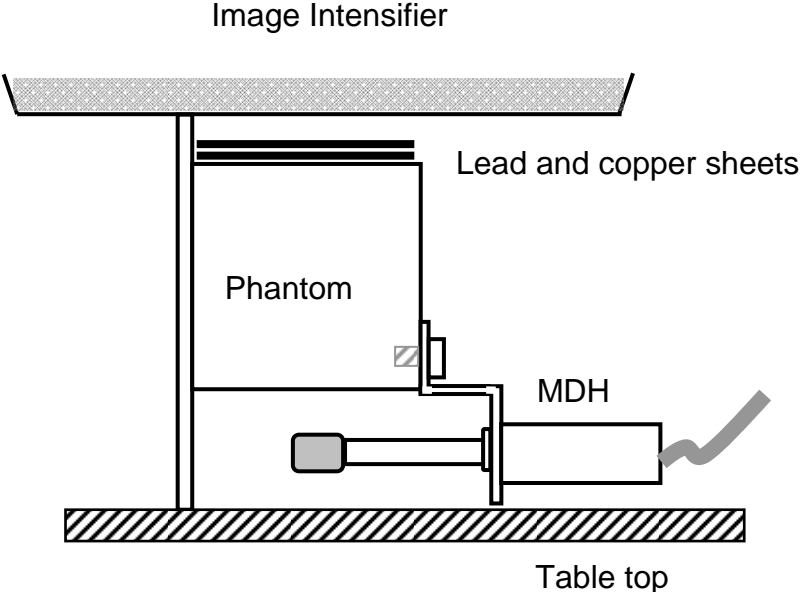

Figure 3. Placement of copper and lead sheets for under-table units.

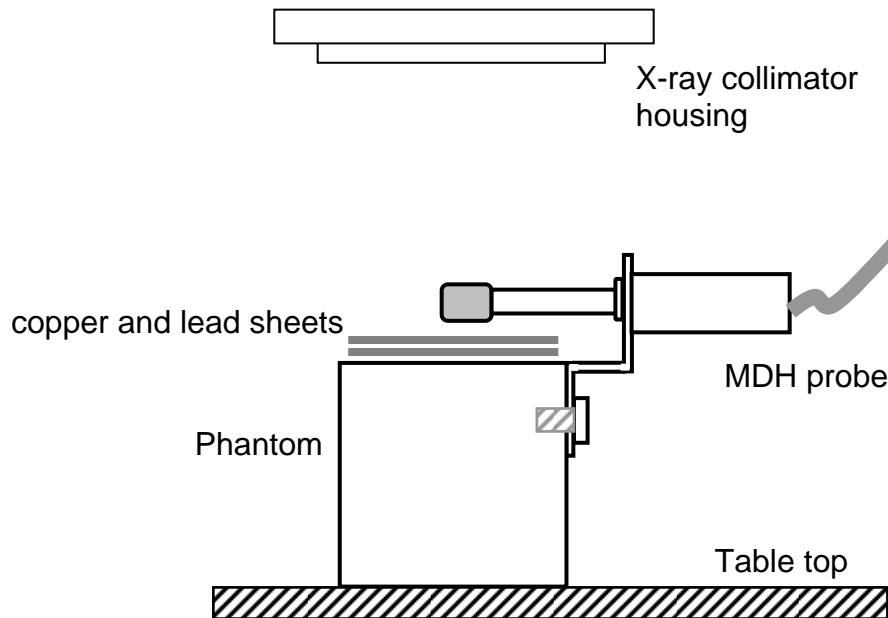

Figure 4. Placement of copper and lead sheets for over-table units.

**6. Fluoroscopic High-Level kVp, mA, and MDH Exposure Rate:
For Over-Table AND Under-Table Set-Ups**

The following measurements are to be made **ONLY** on those systems that have an alternate dose rate option such as high-level mode.

DO NOT make this measurement for MANUAL systems.

Set the MDH selector switch to the "**EXPOSURE RATE**" mode. Without making any changes in the standard patient techniques, with the phantom and MDH probe properly positioned, and the beam collimated to the four markings on the phantom, place the system in the boost mode or high-dose mode of operation and make an exposure until the exposure rate stabilizes. **RECORD THIS EXPOSURE RATE AS FLUORO HIGH LEVEL EXPOSURE RATE #1.** Record the selected kVp as Fluoro High-Level kVp #1, and record the mA value during the exposure as Fluoro High-Level mA #1. Repeat the exposure and record the values for Fluoro High-Level Exposure Rate #2, Fluoro High-Level kVp #2, and Fluoro High-Level mA #2, respectively.

	FLUORO HIGH LEVEL EXPOSURE RATE #1 (mR/min)	FLUORO HIGH-LEVEL mA #1	FLUORO HIGH-LEVEL kVp #1
<u>EXAMPLE:</u>	<u> 0 2 2 0 0 </u>	<u> 0 3 . 0 </u>	<u> 0 9 0 </u>

7. Fluoroscopic High-Level kVp, mA and MDH Exposure Rate with Copper Filter For Over-Table AND Under-Table

The following measurements are to be made **ONLY** on those systems that have the high-level option. **DO NOT make this measurement for MANUAL systems.**

Set the MDH selector switch to the "EXPOSURE RATE" mode. Without making any changes in the standard patient techniques, with the phantom and MDH probe properly positioned and the beam collimated to the four markings on the phantom, place the 1 mm sheet of copper on top of the phantom (see **figure 3 (under-table units) OR figure 4 (over-table units)**), and select the high-level mode of operation. Begin exposure and hold until the meter reading is stable. **RECORD THIS EXPOSURE RATE AS FLUORO COPPER HIGH-LEVEL EXPOSURE RATE #1.** Record the selected kVp as Fluoro Copper High-Level kVp #1, and record the mA value during the exposure as Fluoro Copper High-Level mA #1. Repeat the exposure and record the values for Fluoro Copper High-Level Exposure Rate #2, Fluoro Copper High-Level kVp #2, and Fluoro Copper High-Level mA #2, respectively.

	FLUORO HIGH-LEVEL COPPER EXPOSURE RATE #1 (mR/min)	FLUORO HIGH-LEVEL COPPER mA #1	FLUORO HIGH-LEVEL COPPER kVp #1
<u>EXAMPLE:</u>	<u> 0 4 2 0 0 </u>	<u> 0 8 . 0 </u>	<u> 0 9 0 </u>

8. Maximum High Level Fluoroscopic kVp, mA and MDH Exposure Rate with Copper and Lead for Over-Table AND Under-Table

The following measurements are to be made **ONLY** on those systems that have the high-level option. **DO NOT make this measurement for MANUAL systems.**

Set the MDH selector switch to the "EXPOSURE RATE" mode. Without making any changes in the standard patient techniques, ensure that the phantom and MDH probe are properly positioned, that the beam is collimated to the four markings on the phantom, and that the 1 mm sheet of copper and the lead sheet are placed on top of the phantom (see **figure 3 (under-table units) OR figure 4**

(over-table units). Place the system in the high-level mode and make an exposure until the exposure rate (meter reading) is stabilized.

RECORD THIS EXPOSURE RATE as High-Level Maximum-Exposure Rate #1. Record the selected kVp as High-Level Maximum-kVp #1. Read and record the mA value during the exposure as High-Level Maximum-mA #1. Repeat the exposure and record the values for High-Level Maximum-Exposure Rate #2, High-Level Maximum-kVp #2, and High-Level Maximum-mA #2, respectively.

High-Level Max Exposure Rate #1 (mR/min)	High-Level Max Max mA #1	High-Level Max Max kVp #1
--	--------------------------------	---------------------------------

EXAMPLE: | 2 | 5 | 0 | 0 | 0 | | 3 | 5 | . | 0 | | 1 | 1 | 0 |

**REMOVE THE COPPER AND LEAD SHEETS
FROM THE TOP OF THE PHANTOM.**

9. Film Recording Data

If the facility uses film recording as a part of the upper GI examination, record the selected technique factors (kVp, mA, mAs, and time). Using the procedure below, measure and record the MDH exposure, MDH time.

If the facility uses both spot and photo-spot, do your recording and measurements for the spot film system only.

CAUTION: RAISE THE I.I. HOUSING TO ALLOW ADEQUATE SPACE FOR THE COMPRESSION CONE TO COME INTO THE FIELD DURING FILM RECORDING PROCEDURES.

Select the Four-on-One (4-on-1) mode for ALL spot film recording measurements. If 4-on-1 mode is unavailable, select the mode closest to 4-on-1, such as 2-on-1 or 3-on-1.

SPOT or PHOTO-SPOT TECHNIQUE DATA - Selected kVp and mA: Have the operator set up, at the console, the techniques routinely used for a spot or photo-spot film for the upper GI examination of a standard patient. Record the kVp and mA selected. Leave any missing values coded as blanks.

	SELECTED kVp	SELECTED mA
<u>EXAMPLE:</u>	<u> 1 1 0 </u>	<u> 0 1 5 0 </u>

NOTE: The **ONLY** technique factors, i.e., kVp and mA, recorded are those that are selected **PRIOR TO EXPOSURE**.

Time and mAs (MANUAL MODE ONLY): If AEC is NOT used routinely for spot films, then record the following **MANUAL MODE TECHNIQUE VALUES**. If time is preselected as part of the technique, then record it in the appropriate boxes. Time values are recorded in milliseconds. Some units have preselected mAs; for these units record the mAs value selected and leave the mA and time blank (see note). If the unit gives a post exposure digital readout of mAs, please indicate in the comments section if the mAs value recorded is post exposure.

MANUAL MODE ONLY

EXAMPLE: |0|0|3|3|.3| and / or |0|0|6|7|

NOTE: DO NOT use survey meter reading for the preselected time or mAs. Only those values that are preselected or obtained from the x-ray unit's digital reading should be recorded.

10. Spot or Photo-Spot Film - MDH Exposure and MDH Time

Check to be sure you have removed the copper and lead sheets from the phantom.

MDH Initialization Exposure - Before the MDH can be used to measure exposure time, it must first be initialized. Set the MDH selector switch to the "**PULSE EXPOSURE**" mode. The pulse fraction threshold should be set at 0.2 for single-phase units and 0.5 for three-phase units (if the phase of the unit is not known, use 0.5). Set the x-ray unit for the **four-on-one (4-on-1) format**. Place a loaded spot film cassette in the unit and without making any changes in the standard patient techniques, with the phantom and MDH probe properly positioned (see above), and the beam collimated to the four markings on the phantom, make a single spot film or photo-spot exposure.

RECORD THE EXPOSURE as Film Exposure #1. DO NOT RECORD THIS INITIALIZING TIME.

FILM
EXPOSURE # 1 (mR)

EXAMPLE: | 0 | 1 | 0 | 0 |

NOTE: **DO NOT** manually reset the MDH to zero between exposures.

MDH Exposure and MDH Time - Once you have initialized the MDH, you are ready to make subsequent exposures. Make an exposure, read and record the exposure measurement in mR as exposure #2. Switch the MDH to the "**PULSE DURATION**" mode; read and record the "MDH Measured Time" as film #2-Time. Repeat this procedure; read and record exposure and the time for films #3 and #4 (see the data form for this survey). The processed film should be retained, the optical density determined, and the radiograph sent along with the other data.

NOTE: DO NOT FOLD THE FILM FOR MAILING PURPOSES

FILM
EXPOSURE #2 (mR)

FILM
TIME #1(msec)

EXAMPLE: | 0 | 1 | 0 | 0 | | 0 | 0 | 3 | 3 | . 9 |

Spot Film Density: With the densitometer measure the film density in the center of each of the four images of the phantom on the film obtained for the routine spot or photo-spot procedure. Record the average optical density of the four images in the appropriate boxes provided.

SPOT FILM
FILM DENSITY

EXAMPLE: | 1 | . | 3 | 7 |

11. **Spot or Photo-Spot Data - with Copper Filter**

Selected kVp and mA with Copper Filter - Have the operator set up, at the console, the techniques routinely used for a spot or photo-spot film for the upper GI examination of a standard patient with barium in the beam. Record the 'film Copper Filter' kVp and 'film Copper Filter' mA selected. Leave any missing values coded as blanks.

	SELECTED FILM COPPER kVp	SELECTED FILM COPPER mA
<u>EXAMPLE:</u>	<u> 1 1 5 </u>	<u> 0 2 0 0 </u>

NOTE: The **ONLY** technique factors, i.e., kVp and mA, recorded are those that are selected **PRIOR TO EXPOSURE**.

Time and mAs with Copper Filter - (Manual Mode ONLY): If AEC is NOT used routinely for spot films, then record the **MANUAL MODE TECHNIQUE VALUES**. If time is preselected as part of the technique, then record it in the appropriate boxes. Time values are recorded in milliseconds. Some units have preselected mAs; for these units record the mAs value selected and leave the mA and time blank (see note). If the unit gives a post exposure digital readout of mAs, this value should be indicated in the comments section.

	<u>M A N U A L M O D E O N L Y</u>	
	<u>TIME</u> (msec)	<u>mAs</u>
<u>EXAMPLE:</u>	<u> 0 0 5 8 . 7 </u>	and / or <u> 0 1 3 7 </u>

NOTE: DO NOT use survey meter reading for the preselected time or mAs. Only those values that are preselected or obtained from the x-ray unit's digital reading should be recorded.

SPOT or PHOTO-SPOT FILM - MDH EXPOSURE and MDH TIME with Copper Filter:

Place the 1 mm sheet of copper on top of the phantom. Use a loaded cassette for the copper spot film measurements; this film may be discarded following exposure measurements.

MDH Initialization Exposure with Copper Filter: The MDH **must be re-initialized** before it can be used to measure exposure time for the copper. Set the MDH selector switch to the "**PULSE EXPOSURE**" mode. The pulse fraction threshold should be set at .2 for single-phase units and .5 for three-phase units (if the phase of the unit is not known, use .5). Set the x-ray unit for the **four-on-one (4-on-1) format**. Without making any changes in the standard patient techniques, with the phantom and MDH probe properly positioned, and the beam collimated to the four markings on the phantom, take a spot or photo-spot film.

RECORD THE EXPOSURE as Film Copper Exposure #1. DO NOT RECORD THIS INITIALIZING TIME.

Film with Copper Filter
EXPOSURE # 1 (mR)

EXAMPLE: | 0 | 3 | 1 | 0 |

DO NOT manually reset the MDH to zero between exposures. Once you have initialized the MDH, you are ready to make subsequent exposures. Make an exposure, read and record the exposure measurement in mR as Film Copper Exposure #2. Switch the MDH to the "**PULSE DURATION**" mode, and record the "MDH Measured Time" as Copper Film #2-Time. Repeat this procedure twice more, reading and recording Film Copper exposure and time #3 and #4.

Film with Copper
EXPOSURE #2 (mR)

Film with Copper
Time # 1 (msec)

EXAMPLE: | 0 | 3 | 1 | 1 | mR

| 0 | 1 | 3 | 3 | . | 0 |

REMOVE THE COPPER FROM THE TOP OF THE PHANTOM

F. RADIOGRAPHIC/ FLUOROSCOPIC HVL & IMAGE EVALUATION

1. General Guidelines for Half-Value Layer Determination

The type of unit will determine the procedure you use to determine the HVL. The manual mode method is preferred.

For manual systems and/or ABC systems that can be placed into the manual mode, follow the procedure outlined in Section 2.

For the ABC units that cannot be placed in the manual mode, use the procedure in Section 3.

For over-table units, see Section 4.

For the HVL measurements on all units, **USE** the same kVp used for the fluoroscopic abdominal (**e.g., upper G.I.**) examination.

HVL Method: Indicate in the box provided, the method you used to determine the HVL. If the manual technique was used, code the box "M" and for the fixed aluminum method, code it "A". If you used another method, code the box "O" and provide us with an outline explaining your method.

HVL METHOD

EXAMPLE: | M |

Estimated HVL: Using the graph on the back of the work sheet, plot the exposure rate versus the aluminum thicknesses used. Determine the HVL to the nearest tenth of a millimeter of aluminum by drawing the best straight line fit to all but the first (0 mm Al) data points.

ESTIMATED HVL

EXAMPLE: | 0 | 4 | . | 5 |

2. Manual Mode HVL for Under-Table Tube (PREFERRED METHOD)

The unit must be in the manual mode with automatic brightness control (ABC) disabled, for this method.

- a) With the phantom and the MDH probe properly positioned (see figure 1), adjust the size of the fluoroscopic beam until it is slightly larger than the sensitive volume of the MDH probe head.
- b) Set the MDH selector switch to the "**EXPOSURE RATE**" mode.
- c) Without making any changes in the standard patient techniques, make an exposure until the MDH reading stabilizes. Adjust the mA to obtain an exposure rate of at least 1000 mR/min (1 R/min).
- d) **Record the kVp in the HVL section of the data form. RECORD THE EXPOSURE RATE** in mR/min as Exposure Rate for 0 mm of aluminum, e.g., 1.20 R/min is coded as 01200.0 mR/min and 12 R/min is coded as 12000.0 mR/min.

	<u>HVL kVp</u>	<u>mR/min with 0 mm Al</u>
<u>EXAMPLE:</u>	<u> 0 9 0 </u>	<u> 0 1 2 0 0 . 0 </u>

- e) Place 1.5 mm aluminum on the table top directly beneath the sensitive volume of the MDH probe and make a second exposure until the MDH reading stabilizes (figure 5). Record the output in mR/min in the spaces provided for 1.5 mm of aluminum.

	<u>mR/min with 1.5 mm Al</u>
<u>EXAMPLE:</u>	<u> 0 0 9 2 5 . 0 </u>

- f) Place an additional 1 mm of aluminum on the table top directly beneath the sensitive volume of the MDH probe. Make an exposure until the MDH reading stabilizes and record in mR/min the reading for 2.5 mm of aluminum.

mR/min with 2.5 mm Al

EXAMPLE:

| 0 | 0 | 7 | 9 | 2 | . | 0 |

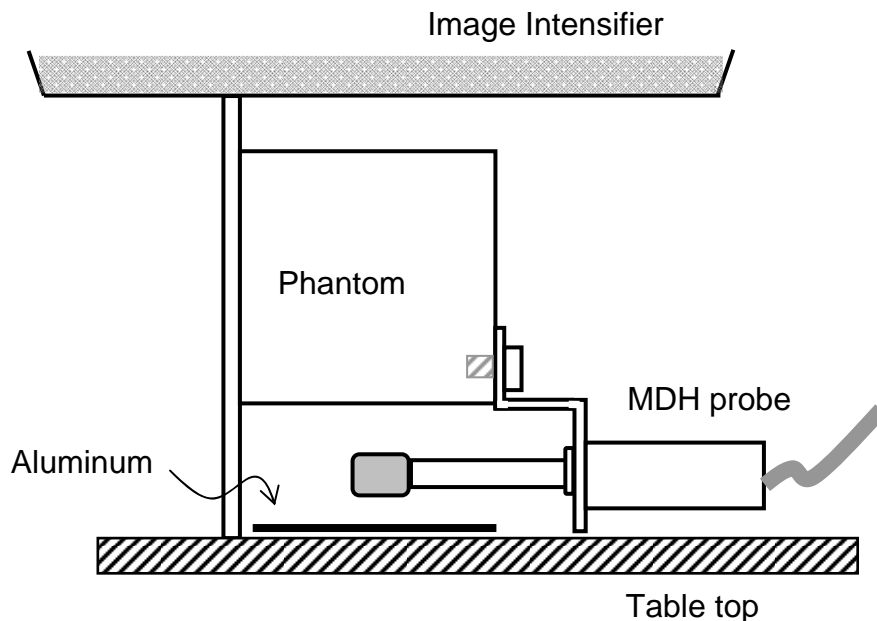

Figure 5. Placement of aluminum for HVL determination on under-table units.

- g) Place an additional 1 mm of aluminum on the table top directly beneath the sensitive volume of the MDH probe. Take an exposure until the MDH reading stabilizes and record in mR/min the reading for 3.5 mm of aluminum.

mR/min with 3.5 mm Al

EXAMPLE:

| 0 | 0 | 6 | 1 | 2 | . | 0 |

- h) If the value obtained with 3.5 mm Al is not less than 1/2 the 0 mm Al value, add as much Al filtration as necessary to reduce the exposure rate to less than 1/2 the 0 mm Al value. Record the resulting exposure rate value and the total thickness of aluminum used.

EXAMPLE: $\frac{\text{mR/min}}{0|0|3|0|3|.0|}$ with $\frac{\text{mm AL}}{0|4|.5|}$

3. Fixed Aluminum Method: HVL for ABC Units that CANNOT be Placed in Manual Mode

The following procedure is to be used **ONLY** on those units that cannot be switched into the manual mode for HVL determination.

It is essential that a **fixed** amount of attenuating material remain in the beam between the x-ray tube and the ABC during all measurements. The **POSITION** of the aluminum filters in the beam will vary during the procedure but the **TOTAL** amount of aluminum in the beam will remain constant.

- With the phantom and the MDH probe properly positioned, adjust the size of the fluoroscopic beam until it is slightly larger than the sensitive volume of the MDH probe head.
- Set the MDH selector switch to the "EXPOSURE RATE" mode.
- Place 4.5 mm of aluminum on the table top directly beneath the MDH probe (figure 6a below). This places 4.5 mm of aluminum between the tube head and the MDH probe. Without making any changes in the standard patient techniques, make an exposure until the MDH reading stabilizes and note the exposure rate for 4.5 mm of aluminum.

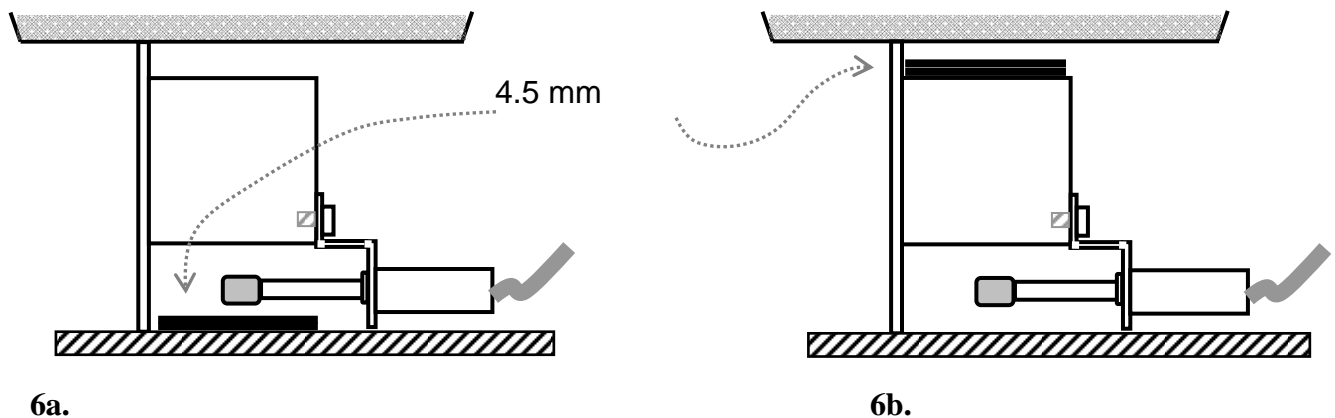

Figure 6. Positioning 4.5 mm Aluminum for the HVL procedure, under-table units.

- Move the 4.5 mm of aluminum to the top of the phantom (figure 6b). Be sure that the aluminum is completely in the beam and is over the MDH probe. This places 4.5 mm of aluminum between the phantom and the

ABC. Make an exposure until the MDH reading stabilizes, and note the exposure rate for 0 mm of aluminum.

- e) If the exposure rate obtained in step 'd' above for 0 mm of aluminum is more than twice the reading obtained in step 'c' for 4.5 mm of aluminum, record the value obtained in step 'd' as the 0 mm of aluminum exposure rate and the value obtained in step 'c' as the 4.5 mm of aluminum value. This procedure ensures that 4.5 mm of aluminum is sufficient for determining the HVL. **Record the console kVp value in the HVL section of the data form. (kVp driven systems may change the kVp value from that used for the phantom only when the aluminum filters are added to the beam.)** Proceed with step g.

	<u>mR/min with 0 mm Al</u>	<u>mR/min with 4.5 mm Al</u>
<u>EXAMPLE:</u>	<u> 0 0 1 2 1 . 0 </u>	<u> 0 0 0 4 5 . 8 </u>

- f) Do this step only if the step 'c' exposure rate value (4.5 mm of aluminum) is not less than 1/2 of the step 'd' exposure. Add more aluminum and repeat steps 'c' and 'd' above until you have sufficient aluminum to exceed the HVL. When you have added sufficient aluminum filtration, record the total amount of aluminum in boxes. Record the value obtained in step 'd' for the total aluminum as the 0 mm of aluminum exposure rate. Record the value obtained in step 'c' for the total aluminum exposure rate value. **Record the console kVp value in the HVL section of the data form. (kVp driven systems may change the kVp value from that used for the phantom only when the aluminum filters are added to the beam.)**
- g) Move 1.5 mm of aluminum from the top of the phantom and place on the table top beneath the MDH probe. This will place 1.5 mm of aluminum between the tube head and the MDH probe, leaving the remainder of the aluminum between the probe and the ABC. Make an exposure until the MDH reading stabilizes, and record the exposure rate (mR/min) for 1.5 mm of aluminum.

	<u>HVL kVp</u>	<u>mR/min with 1.5 mm Al</u>
<u>EXAMPLE:</u>	<u> 0 9 0 </u>	<u> 0 0 0 9 2 . 5 </u>

- h) Move an additional 1 mm of aluminum from the top of the phantom to the table top beneath the MDH probe. This will place 2.5 mm of aluminum between the source and the MDH probe, leaving the remainder of the aluminum between the MDH probe and the ABC. Make an exposure until the MDH reading stabilizes, and record in mR/min the reading for 2.5 mm of aluminum.

- i) Move an additional 1mm of aluminum from the top of the phantom to the table top beneath the MDH probe. This will place 3.5 mm of aluminum between the tube head and the MDH probe, leaving the remainder of the aluminum between the probe and the ABC. Make an exposure until the MDH reading stabilizes, and record in mR/min the reading for 3.5 mm of aluminum.
- j) If only 4.5 mm of aluminum is used to determine the HVL, then leave the boxes for extra aluminum and its exposure value blank. If more is needed, indicate the amount (see step 'f' above).

4. HVL Procedure for Over-Table Units

The unit must be in the manual mode with automatic brightness control (ABC) disabled for this method. NOTE: USE the same kVp used for the fluoroscopic exposure survey.

- a) With the phantom and the MDH probe properly positioned (see figure 3), adjust the size of the fluoroscopic beam until it is slightly larger than the sensitive volume of the MDH probe head.
- b) Set the MDH selector switch to the "**EXPOSURE RATE**" mode.
- c) Without making any changes in the standard patient techniques, make an exposure until the MDH reading stabilizes. Adjust the mA to obtain an exposure rate of at least 1000 mR/min (1 R/min).
- d) **Record the kVp in the HVL section of the data form. THE EXPOSURE RATE** in mR/min as Exposure Rate for 0 mm of aluminum, e.g., 1.20 R/min is coded as 01200.0 mR/min and 12 R/min is coded as 12000.0 mR/min.

	<u>HVL kVp</u>	<u>mR/min with 0 mm Al</u>
<u>EXAMPLE:</u>	<u> 0 9 0 </u>	<u> 0 1 2 1 0 . 0 </u>

- e) Secure (tape) 1.5 mm of aluminum to the collimator directly over the sensitive volume of the MDH probe (or place it on the support plate) and make a second exposure until the MDH reading stabilizes. Record the output in mR/min in the spaces provided for 1.5 mm of aluminum.

	<u>mR/min with 1.5 mm Al</u>
<u>EXAMPLE:</u>	<u> 0 0 9 2 5 . 0 </u>

- f) Secure (tape) an additional 1 mm of aluminum to the collimator directly over the sensitive volume of the MDH probe (or place it on the support plate). Make an exposure until the MDH reading stabilizes and record in mR/min the reading for 2.5 mm of aluminum.

mR/min with 2.5 mm Al

EXAMPLE: | 0 | 0 | 7 | 9 | 2 | . | 0 |

- g) Add an additional 1 mm of aluminum to the beam directly over the sensitive volume of the MDH probe. Take an exposure until the MDH reading stabilizes and record in mR/min the reading for 3.5 mm of aluminum.

mR/min with 3.5 mm Al

EXAMPLE: | 0 | 0 | 6 | 1 | 2 | . | 0 |

- h) Add an additional 1 mm of aluminum to the beam directly over the sensitive volume of the MDH probe. Take an exposure until the MDH reading stabilizes and record in mR/min the reading for 4.5 mm of aluminum.

mR/min with 4.5 mm Al

EXAMPLE: | 0 | 0 | 4 | 5 | 8 | . | 0 |

- i) This step need **only** be **performed** if the value obtained with 4.5 mm Al is not less than 1/2 the 0 mm Al value. Add as much Al filtration as you feel necessary to reduce the exposure rate to less than 1/2 the 0 mm Al value. Record the resulting exposure rate value and the total thickness of aluminum (in mm).

mR/min XX mm AL

EXAMPLE: | 0 | 0 | 3 | 0 | 3 | . | 0 | with | 0 | 6 | . | 5 |

G. IMAGING OF TEST TOOL & DETERMINING TARGET - TABLE TOP DISTANCE

1. Radiographic & Fluoroscopic High-/Low-Contrast for Under-Table Units

- a) With the phantom properly positioned in the beam. **REMOVE THE MDH PROBE AND ALL ALUMINUM FILTERS.** Have the operator set up the unit with the standard patient techniques (for over-table units see below). Center the "Fluoro Test Tool" (figure 7) on the table top beneath the phantom. The engraved side of the test tool must be toward the phantom; the large aluminum disc should rest on the table top. Select the field size that was used for exposure measurements. Observe the fluoroscopic image and record the number of holes you can see on the inner ring and the number of screen meshes you can see on the outer ring.

	<u>NUMBER OF HOLES SEEN</u>	<u>NUMBER OF MESHES SEEN</u>
<u>EXAMPLE:</u>	<u> 4 </u>	<u> 3 </u>

- b) Next place a loaded cassette in the spot film device, set the format to **one-on-one** (1 on 1) and make a spot film exposure. Record the number of holes and screen meshes that can be seen on the developed radiograph. Note that there are separate answer spaces on the data form for fluoro & film score. You may also want to generate an additional film at this time for use in the darkroom fog test (see Section H).

	<u>NUMBER OF HOLES SEEN</u>	<u>NUMBER OF MESHES SEEN</u>
<u>EXAMPLE:</u>	<u> 4 </u>	<u> 3 </u>

2. Determining Target-to-Table Top Distance for Under-Table Systems

With the "Fluoro Test Tool" in place on the table top beneath the phantom (figure 7), measure, **in centimeters**, and record the distance from the center of the spot film cassette to the table top.

	<u>SPOT-FILM TO TABLE TOP DISTANCE (cm)</u>
<u>EXAMPLE:</u>	<u> 3 7 . 8 </u>

On the processed spot film, measure, **in centimeters**, and record the diameter of the image of the inner aluminum disc (figure 9). There will be two central rings close together on the radiograph. Measure the innermost one.

IMAGE DIAMETER (cm)

EXAMPLE: |0|8| .|8|

Use the following equation to calculate the target-to- table top distance in centimeters and record the value in the boxes provided.

$$\text{Target-to-Table Top Distance} = \frac{4.4 \times \text{SD}}{\text{Diam} - 4.4} \text{ cm}$$

where: SD = Distance, in centimeters, from the center of the spot film cassette to the table top.

Diam = Diameter, in centimeters, of the image of the inner aluminum disk (inner most circle).

TARGET DISTANCE (cm)

EXAMPLE |3|7| .|8|

3. Radiographic & Fluoroscopic High-/Low-Contrast for Over-Table Systems

a) **REMOVE THE MDH PROBE.** With the phantom placed upside down on the table top (see figure 8) and properly centered in the beam, have the operator set up the unit with the standard patient techniques. Center the "Fluoro Test Tool" on the top of the phantom with the engraved side toward the phantom, i.e., the large aluminum disc side up facing the tube. Select the field size that was used for exposure measurements. Observe the fluoroscopic image and determine the number of holes you can see on the inner ring and the number of screen meshes you can see on the outer ring.

NUMBER OF HOLES SEEN NUMBER OF MESHES SEEN

EXAMPLE: |4| |3|

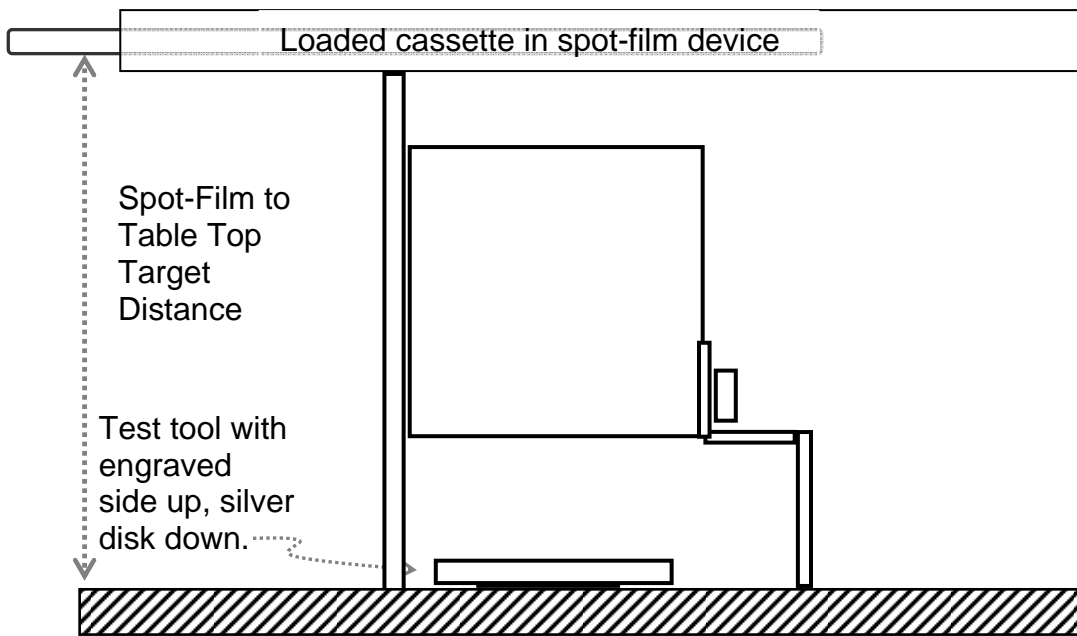

Figure 7. Set-up for fluoroscopic and radiographic high-/low-contrast procedure for under-table units.

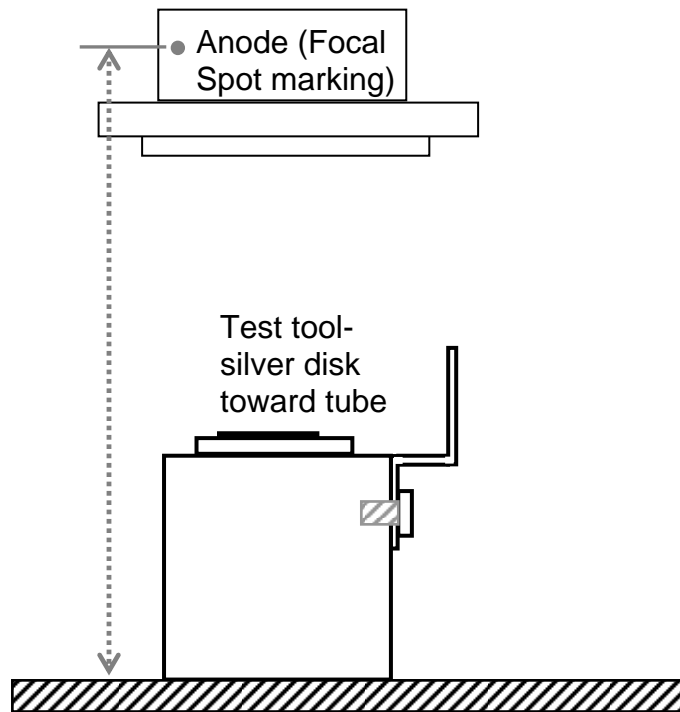

Figure 8. Over-table units: Positioning of test tool and target-table top distance measurement.

- b) Next place a loaded cassette in the spot film device; set the format to **one-on-one** (1 on 1) and make a spot film exposure. Record the number of holes and screen meshes that can be seen on the developed radiograph. Note that there are separate answer spaces on the data form for fluoro & film score. You may also want to generate an additional film at this time for use in the darkroom fog test (see Section H).

	<u>NUMBER OF HOLES SEEN</u>	<u>NUMBER OF MESHES SEEN</u>
<u>EXAMPLE:</u>	<u> 4 </u>	<u> 3 </u>

Copper meshes per in	Contrast hole depths (in)
12	.0063
16	.0091
20	.0126
24	.018
30	.025
40	.035
50	.049
60	.068

Outer diameter: 4 in.
Diameter of silver disk: 2 in.



Figure 9. Fluoroscopic test tool—view of embedded test objects.

4. Target-to-Table Top-Distance Over-Table Units

For over-table units, measure the distance from the anode to the table top and record the distance in centimeters as the target distance (figure 8). With the "Fluoro Test Tool" on the top of the phantom, place a loaded cassette in the spot film device, set the format to one-on-one (1 on 1), and make a spot film exposure. Leave the spot-to-table top distance and image diameter boxes blank for over-table units. **Return these films with your survey form.**

H. PROCESSOR DATA

1. Processor Brand and Model/Chemistry Brand and Type

Determine from the operator the processor-chemistry combination used for the processing of the exposure films. Record the data on the lines provided and from Supplement Sections E and F determine the processor and chemistry codes, respectively, and enter them in the spaces provided. **If the PROCESSOR and/or CHEMISTRY codes are NOT on the list, write their COMPLETE NAMES, and the NAME, ADDRESS AND TELEPHONE NUMBER of the supplier in the comments section. If the chemistry is provided by a local supplier, then code the chemistry "IPCS XXX".**

	PROCESSOR BRAND <u>FUJI</u>	PROCESSOR MODEL <u>RU</u>
<u>EXAMPLE:</u>	<u> F U J P </u>	<u> R U - </u>
	CHEMISTRY BRAND <u>FUJI</u>	CHEMISTRY TYPE <u>HIR</u>
<u>EXAMPLE:</u>	<u> F U J P </u>	<u> H I R </u>

2. Sensitometric Test for the Evaluation of Processing

With the control film provided for the project and the darkroom/processor servicing the x-ray unit/tube surveyed, flash the control film (with the sensitometer) once, on all four sides. Process this film normally as film from the x-ray unit surveyed would be processed. Zero the calibrated densitometer and determine the optical density (OD) of the base (background) plus fog of the processed control film. Record in the space provided.

NOTE: Wait at least 10 seconds between sensitometer flashes.

	<u>BASE PLUS FOG</u>
<u>EXAMPLE:</u>	<u> 0 . 1 8 </u>

Determine the speed density by adding 1.00 to the optical density of the base (background) and fog. Record this optical density on the plotting work sheet.

Select the two steps that have optical densities above and below the speed density. (The step number is labeled on the film.) Read the optical density of each of these two steps twice (once on each of the two sensitometric strips on the film), record this optical density as well as the steps selected on the work sheet. **(If the**

density difference between the same step on the 2 strips is greater than 0.2, repeat the test.)

Average the measured densities for each step. Using the graph on the plotting and work sheet form, plot the step number and the average optical density. Connect these two points with a straight line.

For the optical density of the base-plus-fog plus one, interpolate a sensitometer step number or "speed step." Using this "speed step" and the associated table, determine the processor speed. Record this on the survey form under processor speed index.

If the processor speed index is not between 80 and 120, it is strongly recommended that the test be repeated. Start with a fresh control film and repeat the sensitometric exposure (part 4 above) before proceeding with the speed index calculation.

PROCESSING SPEED INDEX

EXAMPLE: | 1 | 0 | 1 |

NOTE : Label and send this film with the completed survey form.

3. Darkroom Fog Measurement

The following procedure is to be used to measure the darkroom fog level. A darkroom fog test tool has been provided for this measurement and should be used whenever possible.

NOTE: USE FACILITY'S FILM FOR THIS TEST

Make a radiograph of the phantom using a cassette loaded with the facility's film (the radiograph made previously for image evaluation is NOT to be used for this test). You can select the techniques that were used for the spot film exposure measurements. This will provide a test film with a uniform optical density, rather than the range of densities obtained using the Step-Wedge Method.

In the darkroom, remove the film from the cassette and insert the film into the darkroom fog folder (or cover one half of the film with a piece of cardboard). The longest side of the film should be inserted into the fog folder to ensure that you are approximately bisecting the latent image. (This will be true if you center the phantom in the x-ray beam before making the exposure.)

Position the film and folder in an area of the darkroom, usually on the workbench, closest to a safelight. This should represent, in your opinion, an area where film

is routinely handled and has the highest probably of safelight exposure. Expose the uncovered half of the film to normal safelight conditions for two minutes. Make sure that you are not accidentally shielding the film from other potential fog sources such as safelights or digital light sources. After two minutes have elapsed, quickly remove the film from the folder, and process normally.

If a visible border, corresponding to the edge of the mask (and the letters "**FOG**" if using the FDA folder) appears on the film, then you have a fogging problem. Fog levels with a difference of less than 0.10 density units between the fogged and unfogged part of the film may be considered satisfactory for normal film handling times. Fog levels in excess of 0.1 can usually be reduced with minimal effort. Record the film fog level in the boxes provided.

	FILM DENSITY <u>w/o FOG</u>	FILM DENSITY <u>w/ FOG</u>	DARKROOM FOG LEVEL
<u>EXAMPLE:</u>	<u> 1 . 1 8 </u>	<u> 1 . 3 5 </u>	<u> 0 . 1 7 </u>

END OF SURVEY PROTOCOL

2003 NEXT Fluoroscopic Survey

Facility Questionnaire

Thank you for completing this questionnaire. The items below seek information about your facility's diagnostic radiology program. The emphasis of this survey is on equipment used to perform upper G.I. fluoroscopic x-ray exams , but there are also questions covering other aspects of your department. It may be necessary for several persons such as the medical physicist and the QC technologist to contribute to the responses, and *it may wish to review your department records in order to complete this form* . Your reasonable estimates are sufficient for the purposes of this survey. If you have questions about this form you may contact the NEXT surveyor for answers and clarification.

Please return the completed form to the NEXT surveyor as soon as possible.

This section to be completed by surveyor

Surveyor Name	<input type="text"/>	State	<input type="text"/>
Phone	<input type="text"/>	Fax	<input type="text"/>
Address	<input type="text"/>		
Facility Name	<input type="text"/>	Survey Date	<input type="text"/>

Facility personnel: please begin here:

Facility Information

1) Facility person(s) completing this form

a) Name	<input type="text"/>	Title	<input type="text"/>
b) Name	<input type="text"/>	Title	<input type="text"/>
c) Name	<input type="text"/>	Title	<input type="text"/>

2) Number of department staff members : Please enter in the spaces below the number of persons who are :

Radiographic Technologists	<input type="text"/>
Radiologists	<input type="text"/>
Medical Physicists ON STAFF	<input type="text"/>
Medical Physicists BY CONTRACT	<input type="text"/>

3) Diagnostic Imaging Procedures done at your facility. Please estimate the approximate number per month for each procedure indicated.

	Patient Workload - number/ month
General Radiographic Exams (excluding portables)	<input type="text"/>
Portable radiographic exams	<input type="text"/>
Fluoroscopy (general purpose such as GI)	<input type="text"/>
Special fluoroscopic procedures (cardiac, etc)	<input type="text"/>
Mammography (screening only)	<input type="text"/>
Mammography diagnostics (interventional)	<input type="text"/>
Magnetic resonance imaging (MRI)	<input type="text"/>
Computed tomography (CT)	<input type="text"/>
Ultrasound	<input type="text"/>
Dental radiography	<input type="text"/>
Mobile radiographic services	<input type="text"/>
Nuclear medicine imaging	<input type="text"/>
Bone densitometry	<input type="text"/>

4) The following questions concern your department's position with respect to upper gastro-intestinal fluoroscopy. **NOTE:** These questions refer only to equipment used at your facility for performing upper G.I. exams. Do not consider special procedures fluoro suites used for cardiac imaging or other interventional procedures which may use digital technology when you respond to this question.

(Enter A, B, C, or D) :

- A We currently do not use digital imaging for upper G.I. fluoro and do not plan to purchase/convert to digital in the near future.
- B We currently do not use digital imaging for upper G.I. fluoro but we will likely purchase/convert within the next two years.
- C We currently utilize both digital and film based imaging systems for upper G.I. fluoroscopy.
- D We currently use digital imaging for all of our upper G.I. fluoroscopy procedures.

X-Ray Equipment Information

5) How many of the following types of fluoroscopic x-ray systems does your facility have?

General purpose radiographic/ fluoroscopic units	<input type="text"/>
Dedicated angiographic room	<input type="text"/>
Dedicated electrophysiology room	<input type="text"/>
General interventional procedures (eg: cardiac or extremity cath lab)	<input type="text"/>
Mobile C-arm systems (eg: for orthopaedics)	<input type="text"/>

3) Diagnostic Imaging Procedures done at your facility. Please estimate the approximate number per month for each procedure indicated.

	Patient Workload - number/ month
General Radiographic Exams (excluding portables)	<input type="text"/>
Portable radiographic exams	<input type="text"/>
Fluoroscopy (general purpose such as GI)	<input type="text"/>
Special fluoroscopic procedures (cardiac, etc)	<input type="text"/>
Mammography (screening only)	<input type="text"/>
Mammography diagnostics (interventional)	<input type="text"/>
Magnetic resonance imaging (MRI)	<input type="text"/>
Computed tomography (CT)	<input type="text"/>
Ultrasound	<input type="text"/>
Dental radiography	<input type="text"/>
Mobile radiographic services	<input type="text"/>
Nuclear medicine imaging	<input type="text"/>
Bone densitometry	<input type="text"/>

4) The following questions concern your department's position with respect to upper gastro-intestinal fluoroscopy. **NOTE:** These questions refer only to equipment used at your facility for performing upper G.I. exams. Do not consider special procedures fluoro suites used for cardiac imaging or other interventional procedures which may use digital technology when you respond to this question.

(Enter A, B, C, or D) :

- A We currently do not use digital imaging for upper G.I. fluoro and do not plan to purchase/convert to digital in the near future.
- B We currently do not use digital imaging for upper G.I. fluoro but we will likely purchase/convert within the next two years.
- C We currently utilize both digital and film based imaging systems for upper G.I. fluoroscopy.
- D We currently use digital imaging for all of our upper G.I. fluoroscopy procedures.

X-Ray Equipment Information

5) How many of the following types of fluoroscopic x-ray systems does your facility have?

General purpose radiographic/ fluoroscopic units	<input type="text"/>
Dedicated angiographic room	<input type="text"/>
Dedicated electrophysiology room	<input type="text"/>
General interventional procedures (eg: cardiac or extremity cath lab)	<input type="text"/>
Mobile C-arm systems (eg: for orthopaedics)	<input type="text"/>