

Planetarium Activities for Student Success

Activities for the School Planetarium

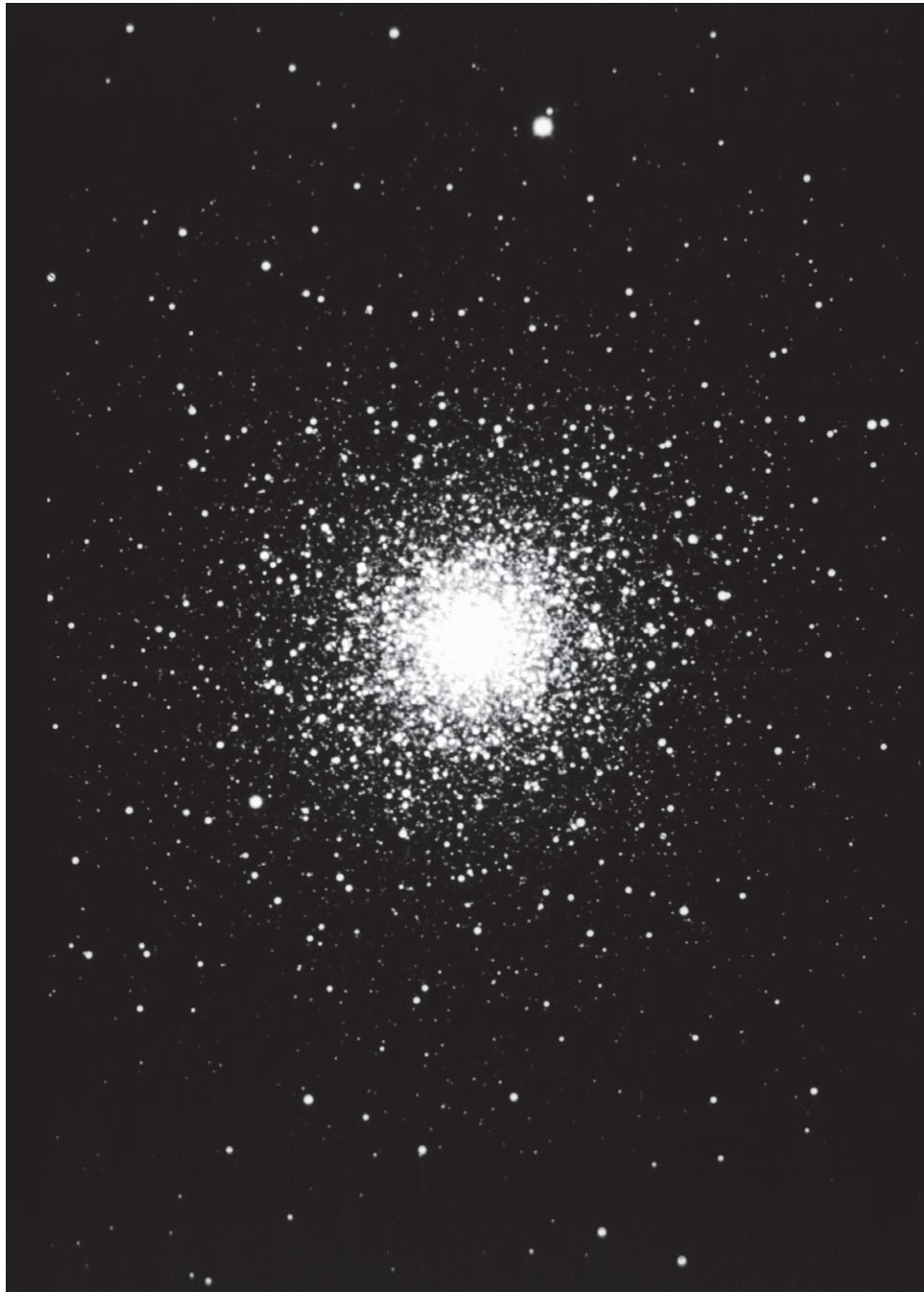

by Gerald Mallon, Ed.D

Cover photograph of the globular cluster M3 (NGC 5272) courtesy of Lick Observatory.

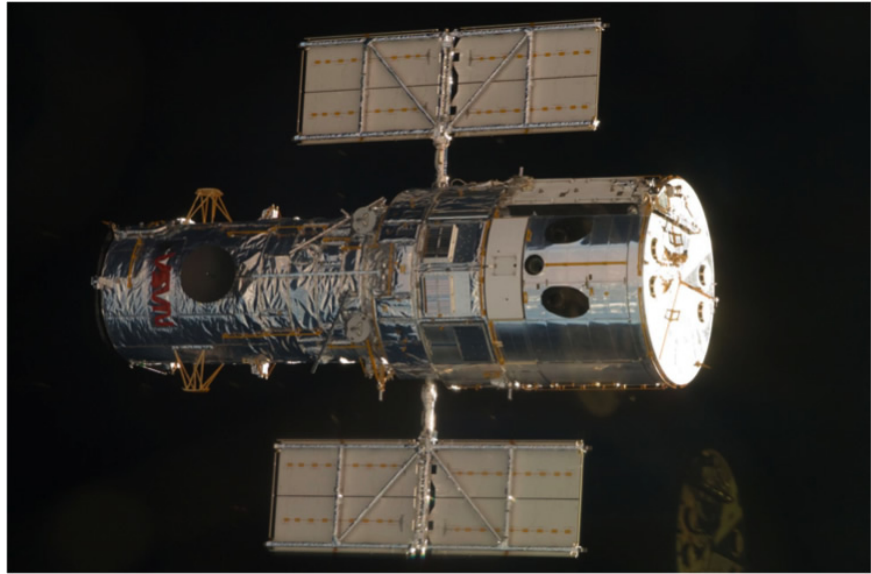

Hubble Space Telescope

This material is based upon work supported by the National Science Foundation under Grant Number TPE-8751779. Any opinions, findings, and conclusions or recommendations expressed in this publication are those of the authors and do not necessarily reflect the views of the National Science Foundation.

Original edition: Copyright © 1990, by The Regents of the University of California.

Revised editions: Copyright © 1993, 2003, 2009 by The Regents of the University of California.

This work may not be reproduced by mechanical or electronic means without written permission from the Lawrence Hall of Science, except for pages to be used in classroom activities and teacher workshops. For permission to copy portions of this material for other purposes, please write to: Planetarium Director, Lawrence Hall of Science, University of California, Berkeley, CA 94720.

The original edition printing of the Planetarium Activities for Student Success series was made possible by a grant from Learning Technologies, Inc., manufacturers of the STARLAB Portable Planetarium.



Lawrence Hall of Science

Planetarium Activities for Student Success

For latest information, valuable links, resources relating to the PASS Classic series, and how to obtain additional copies, visit:
www.planetarium-activities.org

***Activities for the
School Planetarium
Contents***

	Acknowledgments	4
	Introduction	7
	Participatory Planetarium Shows.....	8
	Ways of Thinking About Planetarium Activities.....	15
<i>Grades K-2</i>	Activity 1: Let's Look At the Sky	19
	Activity 2: Shapes In the Sky.....	21
	Activity 3: Night and Day.....	24
	Activity 4: Long Days, Short Days	27
<i>Grades 3-5</i>	Activity 5: Light and the Eye.....	28
	Activity 6: How Do the Stars Appear to Move?.....	31
	Activity 7: Plotting the Paths of Meteors	33
	Activity 8: Measuring the Brightness of Stars	36
<i>Grades 6-9</i>	Activity 9: Observing a Variable Star.....	40
	Activity 10: Using a Blink Comparator	42
	Activity 11: Mythology: Explaining the Unexplainable	43
	Activity 13: A False Color Density Map of the Milky Way	51
	Activity 14: Stars Through the Ages.....	55
	Activity 15: What's Your Sign?	59
	Activity 16: The Trip To Treasure Island	66

Acknowledgments

A grant from the National Science Foundation in 1978 allowed us to publish *The Planetarium Educator's Workshop Guide*, and to present workshops on the Participatory Oriented Planetarium (POP) approach to 100 planetarium directors in 1979.

In 1988, grants from the National Science Foundation and Learning Technologies, Inc. have enabled us to publish *Activities for the School Planetarium* as part of the PASS series. Project Co-Directors were Cary Sneider, Director of Astronomy & Physics Education at the Lawrence Hall of Science in Berkeley, CA, and Alan Friedman, Director of the New York Hall of Science, in Corona, New York. Special thanks are due to our program officers at NSF, Florence Fasanelli and Wayne Sukov.

►
It is often difficult to provide proper credit for the development of educational activities since the teaching profession encourages open sharing of new ideas. However, we have tried to give special credit when we know who developed an original idea, or took the time to write about an activity for distribution to others. All of the authors are to be commended for sharing ideas with their colleagues.

The following activities were first published in the 1980 version of the *Planetarium Educator's Workshop Guide*: Activity 3, Night and Day, incorporates ideas recorded by Jack Permerton and Bill Lawson; Activity 4, Long Days, Short Days, was recorded by Sam Storch and Charles Neleson; Activity 6, How Do the Stars Appear to Move? was first recorded by Carl Rump; Activity 7, Plotting the Paths of Meteors, was recorded by Dean Zollman and Ken Wilson; Activity 9, Observing a Variable Star, was recorded by Cary Sneider and Alan Friedman; Activity 10, Using a Blink Comparator, was recorded by Kingsley Wightman; Activity 11, Mythology: Explaining the Unexplainable, was first recorded by Gerald Mallon; Activity 12, The Reasons for Seasons, incorporates ideas recorded by Charles Neleson, Sam Storch, Ellie Euler, and John Kritzar; and Activity 15, What's Your Sign? incorporates ideas recorded by Keith Johnson and Kent Leo.

Activity 5, Light and the Eye, was published by Gerald Mallon in *The Planetarian*. Activity 13, A False Color Density Map of the Milky Way, was published by Sheldon Schafer in *The Planetarian*.

The following activities were developed by the author and tested in the Methacton School District Planetarium: Activity 1, Let's Look At the Sky; Activity 2, Shapes In the Sky; Activity 8, Measuring the Brightness of Stars; Activity 14, Stars Through the Ages; and Activity 15, What's Your Sign?

We wish to acknowledge the assistance provided by our Advisory Board, who helped to plan this series, and commented on early drafts: Gerald Mallon, Methacton School District Planetarium, Norristown, Pennsylvania; Edna DeVore, Independence Planetarium, East Side Union High School District, San Jose, CA; Philip Sadler, Project STAR, Harvard Smithsonian Astrophysical Observatory, Cambridge, MA; Sheldon Schafer, Lakeview Museum of Arts and Sciences Planetarium, Peoria, IL; Robert Riddle, Project Starwalk, Lakeview Museum of Arts and Sciences Planetarium, Peoria, IL; David Cudaback, Astronomy Department, University of California, Berkeley, CA; and Joseph Snider, Department of Physics, Oberlin College, Oberlin, OH.

Perhaps most important are the approximately 100 individuals from around the nation who attended leadership workshops in 1978, and an additional 200 educational leaders who attended three-week institutes in astronomy and space science at Lawrence Hall of Science during the summers of 1989, 1990, 1992 and 1993. These educational leaders were the first to receive the 1989 edition of the *Planetarium Educator's Workshop Guide* and other volumes in the PASS series including this one, and provided valuable feedback for their final revision. Their names and addresses are listed in the Appendix of *Planetarium Educator's Workshop Guide*.

In addition, we would like to thank the staff of the 1989, 1990, 1992 and 1993 Astronomy and Space Science Summer Institutes: Joseph Snider, Terry Boykie, John Radzilowicz, John Hammer, Robert Jesberg, Jacqueline Hall, Dayle Brown, Alan Gould, Cary Sneider, Michelle Wolfson, John- Michael Seltzer, John Erickson, Lisa Dettloff, Kevin Cuff, Debra Sutter, Chris Harper, Kevin Charles Yum, John Hewitt, Edna DeVore, David Cudaback.

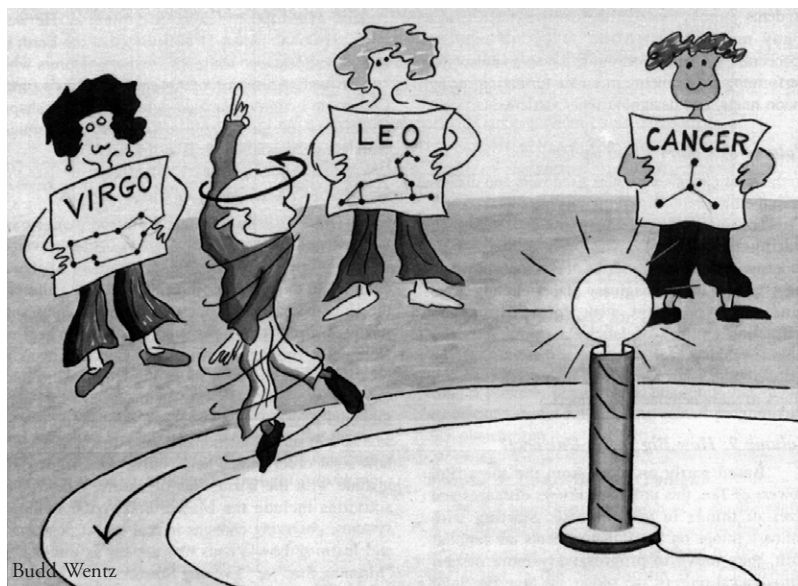

Different Seasons, Different Stars

Illustrations in Activities for the School Planetarium

- p.i, Budd Wentz, Planetarium Comet (drawing)
- p.ii, NASA, CRAF spacecraft (drawing)
- p.3, Budd Wentz, Marking the Sun (drawing)
- p.4, Budd Wentz, Parallax (drawing)
- p.7, Budd Wentz, Variable Star Light Curve (drawing)
- p.8, Budd Wentz, Radio Telescope (drawing)
- p.11, Budd Wentz, Modeling Retrograde Motion
- p.14, Alan Gould, Daytime/Nighttime Sky (drawing)
- p.16, Gerald Mallon, Finding Shapes (drawing)
- p.17, Gerald Mallon, Making Shapes (drawing)
- p.22, Budd Wentz, Music: Here Comes the Sun (drawing)
- p.24, Alan Gould, Eye diagram (drawing)
- p.26, Budd Wentz, Polaris & Star Trails (drawing)
- p.27, Budd Wentz, Making Spinning Stars (drawing)
- p.29, Budd Wentz, Meteors (drawing)
- p.30, Alan Gould, Star Map
- p.33, Gerald Mallon, Brightness of Stars 1 (drawing)
- p.34, Gerald Mallon, Brightness of Stars 2 (drawing)
- p.35, Budd Wentz, Observing a Variable Star (drawing)
- p.35, Budd Wentz, Variable Star Light Curve (drawing)
- p.37, Budd Wentz, Blink Comparator (drawings)
- p.39, Budd Wentz, Great Boat (drawing)
- p.39, Budd Wentz, Great Goat (drawing)
- pp.41–45, Alan Gould, Reasons for Seasons (drawings)
- p.49, Gerald Mallon, False Color Density Map of the Milky Way—Worksheet
- p.51, Budd Wentz, Precession
- pp.52 & 53, Alan Gould, Evening Skies (maps)
- p.57, Budd Wentz, Leo Outline on Dome (drawing)
- pp.58–60, Alan Gould, Zodiac signs (drawings)
- p. 62, Cary Sneider, Latitude by Polaris
- p.67, Carol Becquilla, Map
- p.64–68 Alan Gould (drawings)

In Memoriam

The PASS series editors had the pleasure of working with Gerry Mallon since the very first POPS workshops in 1978. Gerry was a planetarian's planetarian. He was a colleague who could always be trusted to bring quality, imagination, and thoughtfulness to any project he undertook. He had infinite patience and care. His work in the planetarium field was original and seminal; his effort to create curricula promoting multiculturalism and tolerance of diverse life styles was equally important and ahead of its time.

This volume, one of the many publications Gerry wrote to further the field of astronomy education, will continue to share his legacy.

—from the editors of PASS: Alan Friedman, Cary Sneider, Alan Gould

The following is excerpted from "Planetarium Named in Mallon's Honor," an article by Don Hall in *The Planetarian*, March 1992 issue

Gerald Mallon died on November 5, 1991 at age 39. On February 25, 1992, the Methacton Schools in Norristown, Pennsylvania, named the planetarium where Gerald taught for 17 years, in his honor. Students donated money for a plaque outside the planetarium entrance proclaiming it The Gerald L. Mallon Planetarium.

Gerald was honored for his work in science education by the National Science Teachers Association just six years after starting at the planetarium. In 1988, he was recipient of the first Challenger Seven Fellowship, a memorial to the astronauts who lost their lives in the Challenger Space Shuttle disaster. For his Fellowship, he designed and implemented a project that was multicultural and involved middle school students in a simulated mission to one of the planets. This project was a wonderful combination of Gerry's interests in education and astronomy.

Dr. Mallon served as treasurer for the International Planetarium Society (IPS) and was elected president for the term 1993–94, but alas, his life ended before his term could begin. We miss him. He set an example for all planetarians, not only by his dedication to science education, but also through his imaginative use of the planetarium across the school curriculum.

Introduction

The beauty and majesty of the universe can bring awe even to the most hardened of hearts. The night sky holds a special magic over us. It tempts us and humbles us. Through the years, the study of the night sky has yielded answers to mysteries as old as humanity itself. Yet, the universe still contains many more mysteries, perhaps as numerous as the stars in the sky, beckoning to be solved.

The ability to recreate the wonders and mysteries of the universe through a planetarium, offers you, the teacher, a powerful tool for enriching the lives of your students. Students are fascinated by the subject of astronomy and the workings of the planetarium. However, there is an important caution to consider in using such a facility. The planetarium is a tool in the educational process; it is not a teaching machine, nor a toy. It is a tool that in the hands of a skilled educator can open young minds (as well as minds of all ages) to explore the cosmos and comprehend some of its complexities, but to do this it must be used properly.

Like many tools, through time and experience, better ways of using it and improving the end result have emerged. The “Participatory Oriented Planetarium” technique (POP) is one that has been shown to be an effective method for using a small planetarium, especially in a school setting. This philosophy of planetarium programming emerged in the 1970s as an alternative to the “Star Show” (a special-effect spectacular). In a POP program, a live presenter (a teacher) asks questions to provoke two-way interaction with the audience, and hands-on activities involve the participants in learning about the subject matter of the show through their own actions. The attraction of a POP program is not what the students see and hear, but rather what they do and say. To give you a better understanding of this technique, and also a historical overview of its development, you will find an excellent article by Alan Friedman, following this introduction. This article was first published in 1975 and clearly explains the rationale for the POP technique, as well as listing many wonderful activities for such programs.

Constructing an effective planetarium experience requires a careful analysis of the content, the background of the selected audience, and the possible activities that could communicate the topic to the audience. This guide is designed to present you with a few of the methods that have been used successfully by other instructors to integrate these three components into effective planetarium programs. As you review these lessons, you may wish to adopt or adapt some of these ideas for your own programs, or use them as a springboard for inventing your own planetarium activities.

Finally, the use of a planetarium, like the use of any classroom, depends on the background and creativity of the teacher in charge. This set of activities should not be viewed as the only valid uses for a planetarium, but rather as a starting point. Included on these pages are a few sturdy seeds from which to begin planning planetarium usage for your own curriculum and student needs. The planetarium is a remarkable, seemingly magical tool for teaching. The magic, however, isn't in the machine but in the person using it. Good Luck!

Gerald L. Mallon, Ed.D., June 1989

The problem of darkness does not exist for a man gazing at the stars. No doubt the darkness is there, fundamental, pervasive and unconquerable except at the pinpoints where the stars twinkle; but the problem is not why there is such darkness, but what is the light that breaks through it so remarkably; and granting this light, why we have eyes to see it and hearts to be gladdened by it.

—George Santayana,
Obiter Scripta

Introduction

Contributed by:
Alan J. Friedman,
Lawrence Hall of Science;
University of California,
Berkeley

[Editor's Note: This article is one of the first published descriptions of the participatory approach to planetarium programming. It is reprinted from *The Planetarium Director's Handbook*, Number, 32, May-June, copyright 1975, published by Spitz Space Systems, Incorporated, Edited by Michael A. Bennett. Permission is not required for educational use of this material. All other rights reserved.]

Participatory Planetarium Shows

You walk into a dark, round room and sit down. For about 45 minutes you watch exotic visual projections as a disembodied voice lectures about interesting facts, numbers and concepts. You think “gee whiz,” applaud, and walk out. You have just seen a conventional public planetarium show.

Do you remember how you felt after visiting your first planetarium? I remember thinking, “How did they do all those magical effects?” and, “Wow, astronomy sure is neat, but I could never remember all those facts and figures that a scientist has to know.”

Despite the enormous range of topics, most planetarium experiences are remarkably similar. They often succeed as entertainment, and along the way generate some excitement about astronomy, and always make the planetarium director look clever. But I believe there are two other goals that the planetarium show should attempt. We should try to convey some sense of the process of science, and as we do, give our audiences the feeling that they too can be clever about science. Particularly in these days of decreasing support for scientific endeavor, the last thing the public needs to feel is that science is a mysterious process somehow related to creating amazing planetarium illusions, and is far beyond the understanding of normal mortals.

The “participatory” planetarium show is one way to achieve a program that is not only entertaining and exciting, but also gives the audience an understanding of, and even confidence in, the process of science.

At the 1974 meeting of the International Society of Planetarium Educators (Ed. Note: the organization is now named the International Planetarium Society), several directors from large and small planetariums described efforts they have been making to develop participation activities, with considerable success and satisfaction.¹ This article is intended as a first-step guide for other planetarium teachers and directors who would like to begin experimentation with this technique. These activities can substantially improve both the excitement and the educational value of a visit to your planetarium, not only for classes in astronomy, but for “one-shot” group visits and public show audiences as well. The Holt Planetarium at the Lawrence Hall of Science in Berkeley has some form of audience participation in all its public programs, and most of the activities described here have been tested in our shows. None of them require expensive special effects, and all can be done in a small planetarium with a modest amount of preparation time. Most could be adapted to a larger planetarium show seating 100 or more.

1. *IPS Special Report No. 6* October 1974, contains the proceedings of that meeting.

The essential idea is to incorporate into any presentation or topic at least one activity that each member of the audience performs individually. The activity should be obviously related to the topic of the program, and should be fun to do. At the Holt Planetarium we have found two rules helpful in developing successful activities.

1. The activity should be designed so that the audience has the opportunity to discover a basic pattern or principle, and not merely to verify something that you have already told them.
2. If possible, an activity should be open-ended, leading to several possible interpretations, and to new questions and ideas. If the activity suggests new activities to do or try, and if it can be done using the real night sky, it will be even more effective.

Finding and listing activities that have been tried before in class situations is not difficult. There are sources such as *Under Roof, Dome and Sky*,² various publications of the International Planetarium Society,³ *The Planetarium Director's Handbook*,⁴ and, most important, informal conversations with other planetarium directors. Indeed, in trying to give credit for the ideas in the following list, I was frustrated by finding that most of these activities have been invented by numerous individuals independently. The more difficult problem is to develop and integrate activities into a complete single-visit program.

Presenting an activity requires much more patience and teaching skill than lecturing to a passive audience. The best activities are those which at least in part are directed by the audience, and it takes courage to depend on a group of strangers for a substantial chunk of your show, and to consider seriously a suggestion from the audience that you know will turn out to be wrong. But ingenuity and teaching ability are the strong points of the planetarium director, so here is a new way to challenge and exercise your imagination and resourcefulness.

There are substantial rewards for the extra effort involved. In a participatory show you can tell immediately whether your ideas are getting across or not. If the audience is successfully performing behavioral objectives, such as describing the colors they see in a spectrum, or correctly plotting the brightness of a star on a graph, you can directly observe the success of your instructions. It is much harder to tell if your passive-show audience is really following your discussion on the size of the universe, or only tripping out on the color slides.

No two participatory show audiences will respond identically, so you lose much of the boredom that often accompanies the 124th "Christmas Star" pre-

2. This publication is now out of print, although copies may be found in some planetarium libraries. This collection of activities has many excellent ideas, although it is designed for continuing astronomy classes, and most of the activities are tightly directed, designed to confirm concepts taught in the classroom.

3. For a list of publications and other activities of this organization, write to: IPS, c/o Mark Petersen, Treasurer & Membership Chairman, Loch Ness Productions, P.O. Box 3023, Boulder, CO 80307. Back issues of publications available from the Strasensburgh Planetarium in Rochester New York. Permanent mailing address of IPS; c/o Hansen Planetarium, 15 South State St., Salt Lake City, UT 84111.

4. *The Planetarium Director's Handbook* was published by Spitz Space Systems, Inc., Chadds Ford, PA 19317.

5. Gerald Hawkins, *Stonehenge Decoded*, Doubleday and Company, 1965.

sensation, and you even have the possibility of genuine human interactions. I have had a fantasy during some conventional shows that if the audience died midway through the program, the planetarium director would not even be aware of it, and would continue the show, only discovering the tragedy when nobody got up at the conclusion.

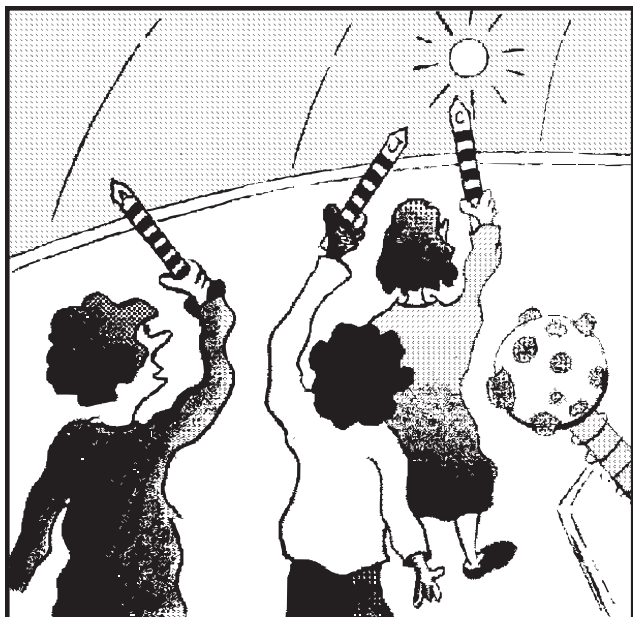

Discovering Patterns in Risings and Settings

A popular show everywhere is “Stonehenge,” explaining Gerald Hawkins’ discoveries that the stones align with solar and lunar risings and settings.⁵ For this activity, you mark the correct azimuth directions for all four Sun alignments at Stonehenge using a horizon projection or arches of cardboard attached to the cove.⁶ After introducing the pre-Hawkins idea about Stonehenge, ask the audience to suggest experiments to try to figure out if these arches have any astronomical significance. If they think some bright stars might rise or set there, go through a night and mark the rising and setting positions with tape or hanging cardboard pointers. As they suggest, try the Sun, moon, and whatever day of the year they want. Eventually, everyone will discover that the Sun’s rising and setting points, on June 21 and December 21 (when the Sun reaches its extreme northern and southern azimuths) are the directions

marked by Stonehenge. In addition to discovering part of Hawkins’ conclusions, your audience will learn on their own that the stars do set in the same places on different days of the year, that nothing sets exactly in the south, and that some stars do not set at all.

New questions will come up — Would Stonehenge work if you put a model in your backyard? Do the Sun and the moon ever set or rise in the same direction? Will a full moon set in the same places as a crescent moon? The procedures can be even more active in a small planetarium if members of the audience can walk around to mark risings or settings on the cove.

Comparing Light Spectra

The essential component of this activity is a 16-cent diffraction grating in a cardboard slide mount⁷ that you give or loan to every member of the audience. These might be included in the admission price, or can be collected and reused many times. Tell the audience that these are scientific instruments, used by astronomers in more elaborate form, then turn on an unfrosted straight-filament light bulb and ask them to discover what the instrument does.

6. Precession does not change the rising and setting azimuths, and planetariums do not normally include the motions that do. Setting the arches to coincide with the azimuths at which your planetarium Sun rises and sets on the solstices, for the latitude of Stonehenge, will result in an error in arch positions of only a few degrees, and provide an accurate simulation.

7. These gratings are available at from various sources such as Edmund Scientific Company, Barrington, New Jersey 08007.

There will be cries of delight as people find the brilliant spectrum, and quickly explain to neighbors how to do it. When everyone has found the spectrum, they can examine other light sources, such as flames (see your old chemistry textbook), neon bulbs, or better yet, a set of emission spectral tubes borrowed from the physics department (also available from many scientific teaching equipment companies). Helium, Mercury, and Neon work best. Let the audience compile a list of differences and similarities. Finally show the simulated light from a star or comet (source in the cove area) and ask them to identify the atomic species in the unknown by comparison with each of the “terrestrial” sources. For a very small planetarium, hydrogen spectra are bright enough to use as sources, and then water vapor makes an excellent unknown.

With younger children it is effective to ask them to draw what they see with crayons. At the end of the show, it's fun to watch people trying the gratings on your exit lights, cell phones, and console illumination. What would they find out about street lights, TV screens, neon signs, or the moon?

Using Parallax as a Measuring Tool

An historically important method for measuring astronomical distances is observation of parallax. For this activity you will need a small flashlight-type bulb suspended by fine wires and powered by some kind of variable-voltage source. The bulb should be roughly centered in the room at least 20% of the dome diameter from the nearest part of the dome surface.

With the house lights out and the starfield on, locate the bulb by turning it up brightly, then dim it to approximate a very bright star (it can also be colored for easy identification). If you have taught the audience some constellations, ask them which constellation the bulb-star is in. Different members of the audience will call out different constellations. Ask them to explain why.

Then ask the audience to observe the bulb while moving their heads from side to side. After discussion, turn on another bulb, this time located only a foot or so from the dome. Now what happens when you move your head from side to side? Does swaying your whole body make a difference?

This activity can be continued using bulbs at different distances from the surface of the dome. One interesting variation is to use two bulbs, a red one located about an inch behind a green one. Some members of the audience see only a green star, some see a red star to the left of the green, and some see the red star to the right. Only by exchanging data from different parts of the room can the full three dimensional configuration be determined. Let the audience try to explain this parallax phenomenon with minimal help, and enlist as many suggestions as possible.

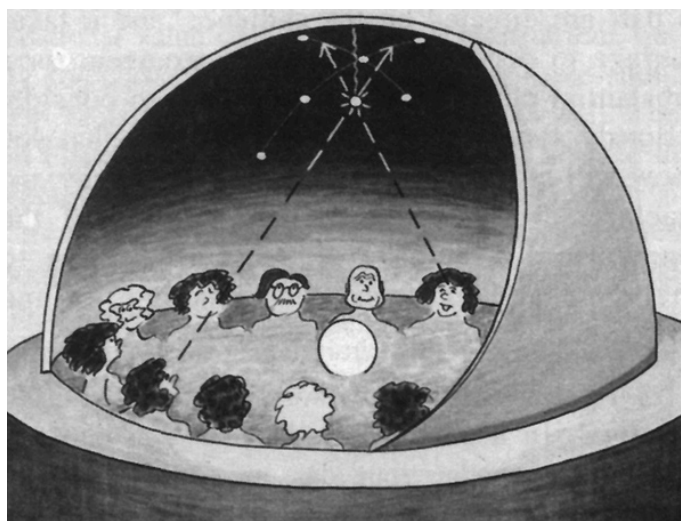

Using a Star Chart

Watching someone point out constellations is one thing, but finding them on your own is quite another. The planetarium director flashes his arrow around the great square of Pegasus and the summer triangle. But when the visitor tries to find these shapes at home, the real sky is much bigger, there is no arrow to indicate the general area, and there are dozens of squares and triangles!

For this activity, the audience discovers the frustrations and rewards of constellation identification immediately. Each member of the audience is given a simple star chart with the fifty or so brightest stars and constellations of the season marked. After a few minutes of explanation, and a demonstration of how to locate the Big Dipper using the chart, the audience is assigned the task of finding the constellations in the planetarium sky. Depending on the size of the audience, constellations can be assigned to small groups or sections of the audience.



In a 5 to 10 minute hunting period, the cove lights are repeatedly turned up and down to let people check their charts against the sky. Don't worry about losing dark adaptation — not being able to see all the fainter stars is an aid, not a hindrance, to finding the major constellations.

Then pass around a battery-operated light pointer to one member of the group so that he or she can point out the group's constellation. This process will take several minutes for each group, and it is amazing how many possible combinations of stars people can find that reproduce a well-known constellation in somewhat distorted size or shape. If you use only five or six constellations, people will not become bored while other groups report their identifications, and the procedure of finding and verifying a constellation will call upon much consultation and discussion within each group. Now every member of the audience has his or her own constellation, and will very likely find it the next clear night at home.

Developing and Testing the Celestial Sphere Model

Assign bright stars to small sections of the audience, and ask them to track their stars as the planetarium goes through a night. Then ask a representative from each section to trace the path of the group's star with a portable pointer. If you selected a well-distributed set of stars, some paths will be small or large circles, some will be shallow arcs, and some apparently "straight" lines. Now ask the audience to formulate a simple model to explain all the motions they observed in as few words as possible. It is rare that audience members will arrive directly at a celestial sphere hypotheses, but they will come up with all sorts of designs, including circles around various points, rotating umbrella patterns, and a rotating Earth (this activity is most interesting if the planetarium is prepared so there is no bright pole star). Challenge the audience to come up with a test to evaluate each model, and check the model, if possible, by further observations of the sky.

Without observing long-term planetary motions, there is no naked eye experiment to discriminate convincingly between a rotating Earth and a rotating celestial sphere. Once the audience has become aware of this, you can ask them questions that will lead to a better appreciation of the celestial sphere. Where is the Earth in relation to this sphere? In the exact center? What would we see differently if we were closer to the eastern side of the sphere than to the western side?

One test the audience may come up with is to observe the apparent separation of a bright pair of stars as they move across the sky. If the Earth is closer to the eastern side, the Gemini twins would grow closer together as they moved across the sky from east to west. Using the finger of an outstretched arm to

measure angular separation, each person in the audience can see if this is true. Some will see the stars move closer together, some will see no change, and some will see them move farther apart. After a show of hands to determine who saw what, ask the audience to explain what happened. You can finally invite them to try the experiment outside on the real sky, and speculate on the results and possible interpretations.

Plot and Interpret a Variable Star Light Curve

This activity requires a “variable” star, made using a single slide projector, a “dot” slide, and a variable power supply to the projector.

Could we learn anything from carefully watching how the brightness of such a star varies? Let’s try it.” Give every member of the audience a piece of simple, wide-space graph paper and a pencil. For convenience, all the stars in the planetarium are turned off except for 6 plus the variable. The 6 comparison stars are projected from a slide which consists of 6 identically sized holes sandwiched with a photographic grey scale. This way, the stars are really of different brightness, not size. Dim magnitude numbers must be projected next to each of the comparison stars, too. Briefly describe the magnitude system to the audience. “Now we would like for each of you to estimate the brightness of this variable star, by comparing it to the fixed stars. Which of the comparison stars is the variable most like? Mark your estimate on the graph paper, above day 1, at the level of brightness you have estimated.” The cove lights are turned up for data recording. Continue the process for 12 days, while adjusting the brightness of the variable each “day” according to a predetermined pattern. We use a simple eclipsing binary system (see “A Completed Variable Star Light Curve”).

When the lights are turned up on the final day, ask everyone to compare his or her results with the people sitting on either side. People are impressed with how good the agreement is, since they were working on individual visual estimates. Most members of the audience have never recorded data or plotted a graph before.

Now ask some questions. What day was the star dimmest? How dim did it get? When did the brightness start to dip the second time? There will be general agreement on the answers, including magnitudes of about plus or minus one unit on your arbitrary scale. Now the most important question: “What might be happening to make the star’s brightness vary like that — first a big dip, then a little dip, every 12 days, for years?”

You should treat each suggestion from the audience as a serious idea to be evaluated. For example, the star might be moving toward and then away from us; it might be swelling or shrinking; a planet might be going around the star, periodically blocking our view. Eventually, with as few hints as possible someone

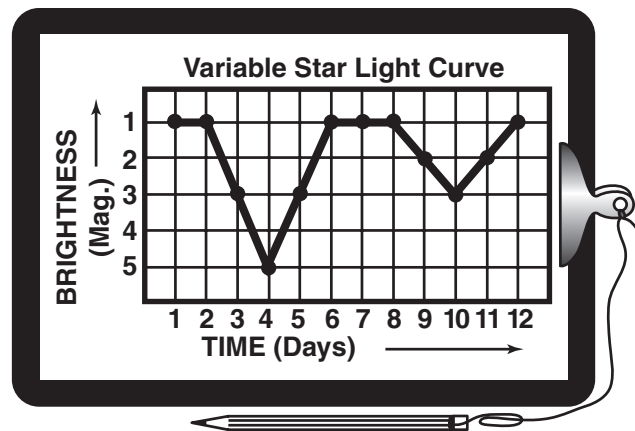

A Completed Variable Star Light Curve. Distribute simple graph paper like this to each member of the audience, and let them plot the data points as you vary the star from “day” to “day.”

9. This activity was first suggested to me by Bob Wambaugh of Connellsville, Pennsylvania.

10. This activity was first suggested to me by Bob Andress of Hiram, Ohio.

Activities for the School Planetarium

will come up with the idea of an eclipsing binary star. Then you can lead the audience through interpretations of the eclipsing binary variable star light curve. “Can you figure out from your graph if the stars involved have the same magnitude or not? How much brighter is one than the other? Which star was being eclipsed on day 5? How about size — are they the same size or different?”

The majority of people in the audience respond to these questions, and even those who do not have their

own graph to consult while the dialog is going on. Your audience has participated in a real analog to the process of data collection and interpretation. [Editor’s Note: A more detailed description of this activity is found later in this guide, Activity 9, Observing A Variable Star.]

And Much, Much More

Using a simple star chart, let everybody plot the path of a comet, a planet going through retrograde, or the Sun.

Use pieces of inexpensive polarizing filters the same way one uses diffraction gratings in Comparing Light Spectra to discover the properties of polarized light.

Let the audience draw their own star charts for the brighter stars, and compare their charts for several seasons. Which stars stick around and which ones disappear?⁹

Ask the audience to time the orbits of the planets on the projection orrery, using their wristwatches. Can they detect any patterns in the results?¹⁰

Ask the audience to qualitatively describe the color changes (governed by blackbody radiation law) as you slowly increase the voltage on an unfrosted light bulb.

Describe rough celestial navigation (height of Polaris = observer’s latitude) and let the audience estimate position, given a map of the world and their longitude. Confirm their estimates by turning on the geocentric Earth projector.

Ask the audience to figure a way to define “north” given a sky with no pole star.

The list of entertaining and educational activities that you can incorporate into a single-visit public planetarium show is unlimited. Most of these activities can be tested with rough setups, since the “realism” is in the process of invention and discovery, not in the quality of the illusion.

Most valuable is the new relationship you have with your audience. It’s also important to match of the level of understanding required for an activity with the grade level(s) of the audience. No two activity-based shows are the same, and you will get immediate feedback on the extent to which you are able to engage the imagination of your visitors. At the end of the show, people are more likely to say “I enjoyed doing that,” rather than “That was a great presentation.” But after all, the goal of the participatory program is to make the audience look good, not the planetarium machinery.



Ways of Thinking About Planetarium Activities

Volume 1 of the PASS series presents a framework for thinking about participatory planetarium programs. These same ideas are useful in adapting activities or inventing your own planetarium activities. Following is a brief summary and review of the materials covered in *Planetarium Educator's Workshop Guide*, plus some additional information about identifying behavioral objectives.

A Framework for Viewing Planetarium Activities

Every planetarium experience can be thought of as a combination of three interrelated factors: the topic of the program, the student, and the planetarium instructor. These can be represented by three interwoven circles.

1. **The Topic**—The images, sounds, facts, concepts, skills, and attitudes that you wish to communicate to the visitor.
2. **The Student**—His or her background experiences, perspectives, interests and learning abilities.
3. **The Instructor**—All the strategies that are used to communicate the topic of the program to the student. (The actual instructor can be a person or a machine.)

Effective education occurs at the intersection of all three circles. In order to construct an activity so that the three circles intersect, you must have some idea of the reasoning level and background of the students, as well as the requirements of the topic. You must then select strategies that can effectively communicate the information to the students. Research has shown that strategies that involve the students directly can be effective vehicles for communication.

In attempting to develop a planetarium lesson which matches topic, student and instructor to one another, there are five major components for you to consider. 1) What are your objectives? 2) How will you organize the lesson? 3) What are the reasoning skills required of the students? 4) Which questioning and activity strategies will you use? 5) What are your specific objectives for the students? The following is a summary of these four ways of thinking about planetarium activities.

Identifying Objectives

At some point in the process of adapting an activity or devising a new one for your students, it is valuable to list the objectives which you hope to achieve. Following are some tips in identifying appropriate objectives.

1. Objectives are not things that the instructor is to do, but rather changes that you hope will occur within your students.
2. Objectives should be specific, in keeping with a particular area of study.
3. Objectives should use an appropriate verb to describe what the student can do when the instruction has been successful. It is not enough to say that students should “understand;” you must be able to evaluate the students’ understanding. How will the student demonstrate understanding, under what conditions, and what is the acceptable level of performance?

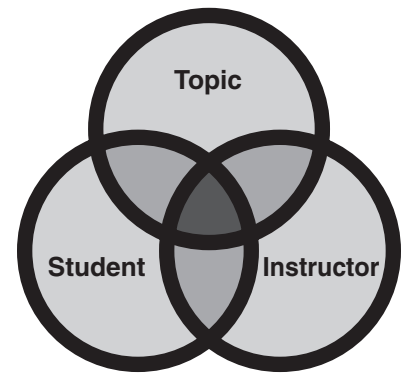

Activities for the School Planetarium

- Objectives should require students to perform at various levels of thinking, and not be limited to simply the knowledge level. Bloom has listed six levels in his Taxonomy of Educational Objectives: Knowledge (eliciting facts, testing recall and recognition), Comprehension (translating, interpreting, summarizing), Application (using in situations new, unfamiliar or with a new slant), Analysis (breaking down into parts, forms), Synthesis (combining elements into a pattern not clearly there before), and Evaluation (evaluating according to some set of criteria and stating why).

Example: Compare these two objectives. Which would allow you to know if the objective has been met? What are the conditions under which the student will be evaluated? What is the acceptable level of performance?

- By the end of the lesson, students should learn about constellations.
- By the end of the lesson, students should be able to locate at least three constellations in the planetarium sky, using a star chart and a flashlight pointer.

Organization Patterns

In planning a planetarium activity, different patterns of organization are available. Which pattern is best for the objectives you wish to achieve?

- Didactic Organization**—Communication is entirely one-way: from the instructor to the students.
- Small Group Task Organization**—This organization allows the students to interact with other students while working on a common task.
- Individual Task Organization**—Each student makes his or her own observations or solves a problem on his own.
- Informal Discussion Organization**—This pattern of organization allows free, uninhibited discussion by the students among themselves.
- Group Meeting Organization**—The group meeting is primarily problem-centered, with the instructor or a student acting as a facilitator.
- Socratic Organization**—The planetarium instructor takes the role of questioner and responder.



Student's Reasoning Skills

People's abilities to solve problems increase as they mature. The following guidelines may help you design activities that are age appropriate.

- Egocentric** (starts about age 4)—Students can imagine only their own point of view. They can notice similarities and differences. Simple associations and human motives are attributed to inanimate objects. e.g., "The Sun rises so we'll feel warm."
- Concrete** (starts about age 8 or 9)—Students can imagine another viewpoint only after a concrete experience. Beginning with classification by a single trait, they can later recognize that an object may belong to more than one class and can arrange objects along a continuum. More complex relationships between various elements familiar to the individual can now be used to explain phenomena. New observations can be appropriately used in revising explanations.

3. **Formal** (starts about high school age) - Students can imagine a situation from different points of view. They can arrange objects in a hierarchy and then rearrange objects in a new hierarchy. Students can extend explanations to predict observations and objectively compare their own explanations with alternatives by controlling variables and making probability arguments.

Questioning and Reasoning Strategies

Several different questioning and reasoning strategies are available to reach different objectives:

1. **Direct Information**—The student recalls information or recognizes information that is readily observable.
2. **Synthesizing**—The student draws some relationships from information that was recalled or observed.
3. **Open-Ended**—The student explores freely and comes up with one of a wide range of acceptable solutions.
4. **Feeling**—The visitor makes a judgement based on feelings.
5. **Other**—Rhetorical and Managerial.

Once you've developed a planetarium activity, it is wise to check its effectiveness periodically. Your students' satisfaction by using blank comment cards on which your audience can list what they liked and didn't like about the program. You can assess learning by pencil-and-paper tests, or interviews with questions which indicate whether or not the objectives of the activity were met. For school groups, test forms can be given to teachers to administer to their pupils a few days after the program. Feedback on student learning and satisfaction can serve as a rich source of information to improve specific parts of the planetarium program.

Sample Activities

As discussed in the previous section, developing a planetarium lesson involves carefully constructing the activity so that it: matches the cognitive level of the students; uses an appropriate organizational pattern for the topic; employs effective questioning strategies; and has clear and measurable behavioral objectives.

The following activities have been created and used by other planetarium instructors. They are offered here as sample activities which you may wish to adopt, adapt, or refer to as inspiration for inventing new activities to teach the topics of greatest interest to you and your students. In addition to these activities, the reader is urged to examine the Interact! PASS Classic planetarium shows for suggestions for teaching about constellations, star maps, the moon, etc.



Activities for the School Planetarium

Each of the lessons was prepared for a particular audience. The lessons have been categorized as appropriate for students in Primary (K-2), Upper Elementary (3-5), and Middle School (6-9). These grade level designations are based in part on the science curriculum used in many schools as well as the general cognitive level of the student that would be required for the lesson.

However, many of these lessons could be adapted by a creative teacher for use in other grade levels, and therefore the recommendations should be considered simply as a general suggestion rather than as a rule for use. Also, an activity can be categorized in more than one way, depending on how you present it to the students, or the type of responses you are willing to accept. Therefore, use the suggested organization pattern, reasoning level and activity strategy as a guide rather than as a rule.

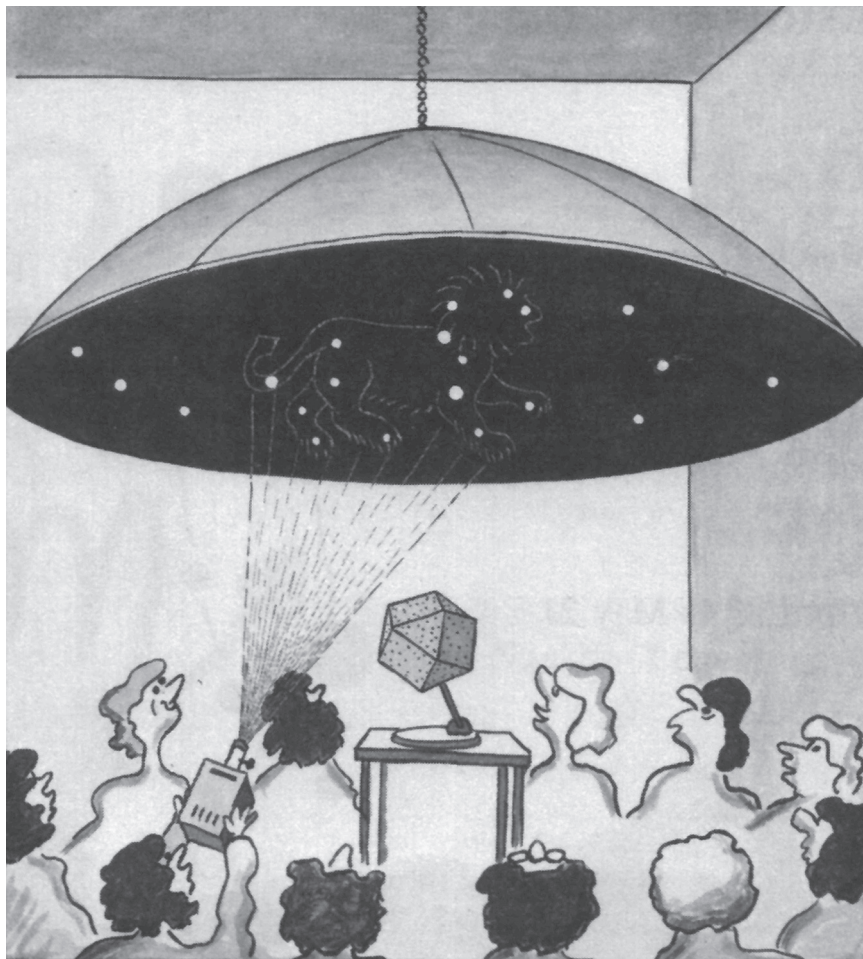

Activity 1: Let's Look At the Sky

Grade Levels: K-2

Organization: Socratic, Individual Task

Reasoning Level: Egocentric

Activity Strategy: Direct Information

Behavioral Objectives: By the end of the lesson, students should be able to:

1. Describe some of the things that appear in the sky.
2. Draw a picture of a day sky and a picture of a night sky.

Presentation

Ask the students if they are good at pretending. With the help of the planetarium, they are going to pretend to watch the sky for a whole day and night in order to find out what objects can be found in the sky.

In the first activity students describe things that they have seen in the day sky, while various phenomena are projected onto the dome. (Ask the students to think of things that are natural and not things that have been made by people—like airplanes.) Possible items to show (and play day sounds) include:

1. The Sun low in the morning sky and how it seems to change its positions (demonstrated by turning daily motion on and off during the lesson.)
2. Clouds in the sky. Clouds blocking out the Sun.
3. A rain storm possibly with lightning.
4. A rainbow after the storm.
5. A first quarter moon rises at about noon.

Hand out data sheets and ask the students to draw a picture of the day sky in the upper “window,” showing some of the things that could be found in the sky.

In the next activity the students watch the Sun appear to set as the sky darkens. Ask the students to tell the class about things that are in the night sky while you demonstrate various phenomena for them. Possible items to show (and play night sounds) include:

1. The stars—more are seen the darker it gets.
2. The moon is seen and it is easier to find than in the day sky.
3. A meteor, or “shooting star.” (Moving the flashlight pointer quickly across the dome can simulate this.)

The purpose of this introductory planetarium activity is to encourage the students to observe, record, and talk about what they see in the daytime and nighttime sky. By looking at your students' data sheets, you will be able to see how they perceive sky phenomena, and what they find to be most interesting.

Materials

- slides or posters of sky phenomena
- recording of day and night sounds

Optional

- water pistol or squirt bottle to add realism to the rain storm

For each student

- one pencil
- copy of the data sheet (master on page 20)
- a clipboard or other hard writing surface

4. A planet—looks like a star unless you have a telescope or a pair of binoculars to help your eyes.
5. The moon, stars, and planets appear to move across the sky.

As a closure activity, ask the students to use the bottom “window” of their data sheets and draw a picture of the night sky with items that could be found there. Finally, urge the students to look up and see some of these things in the real sky after they leave the planetarium.

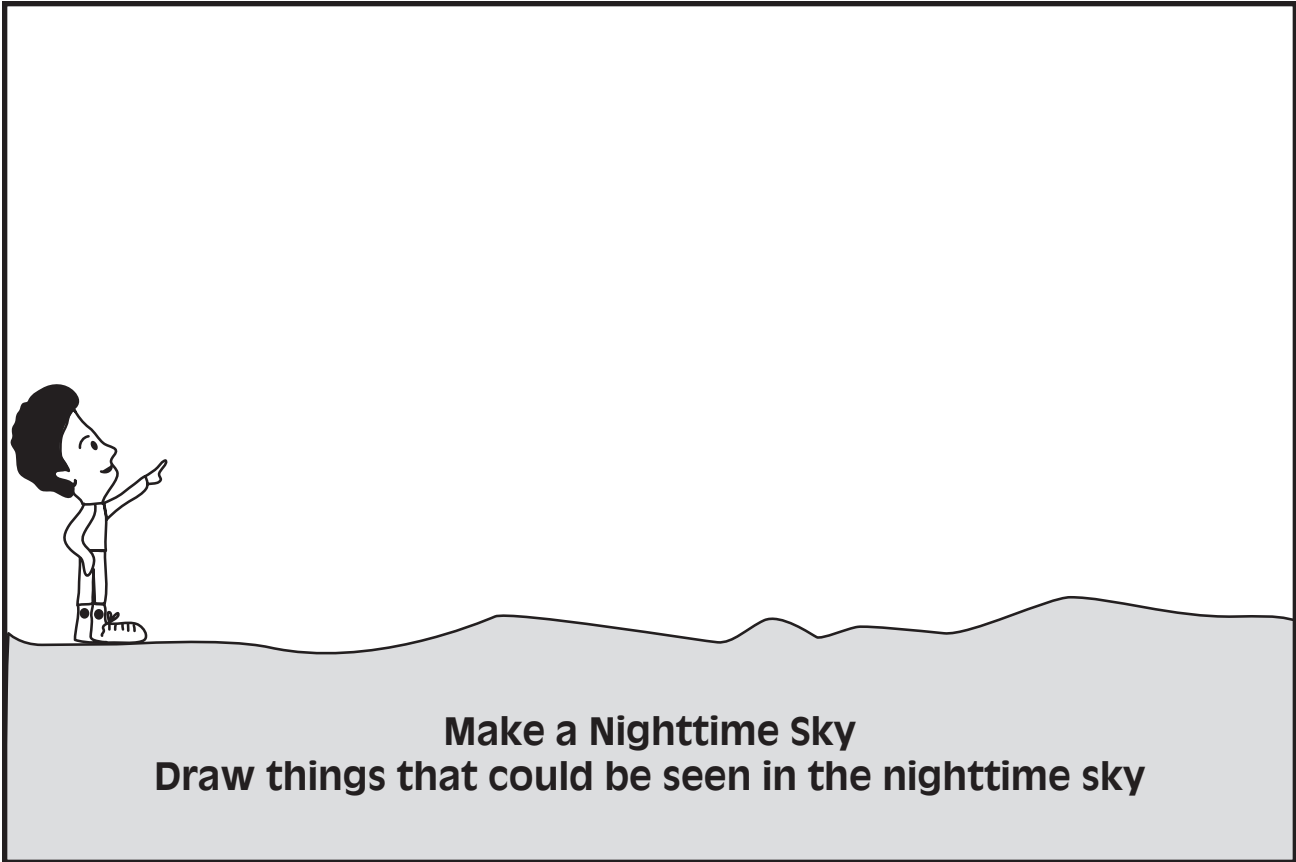
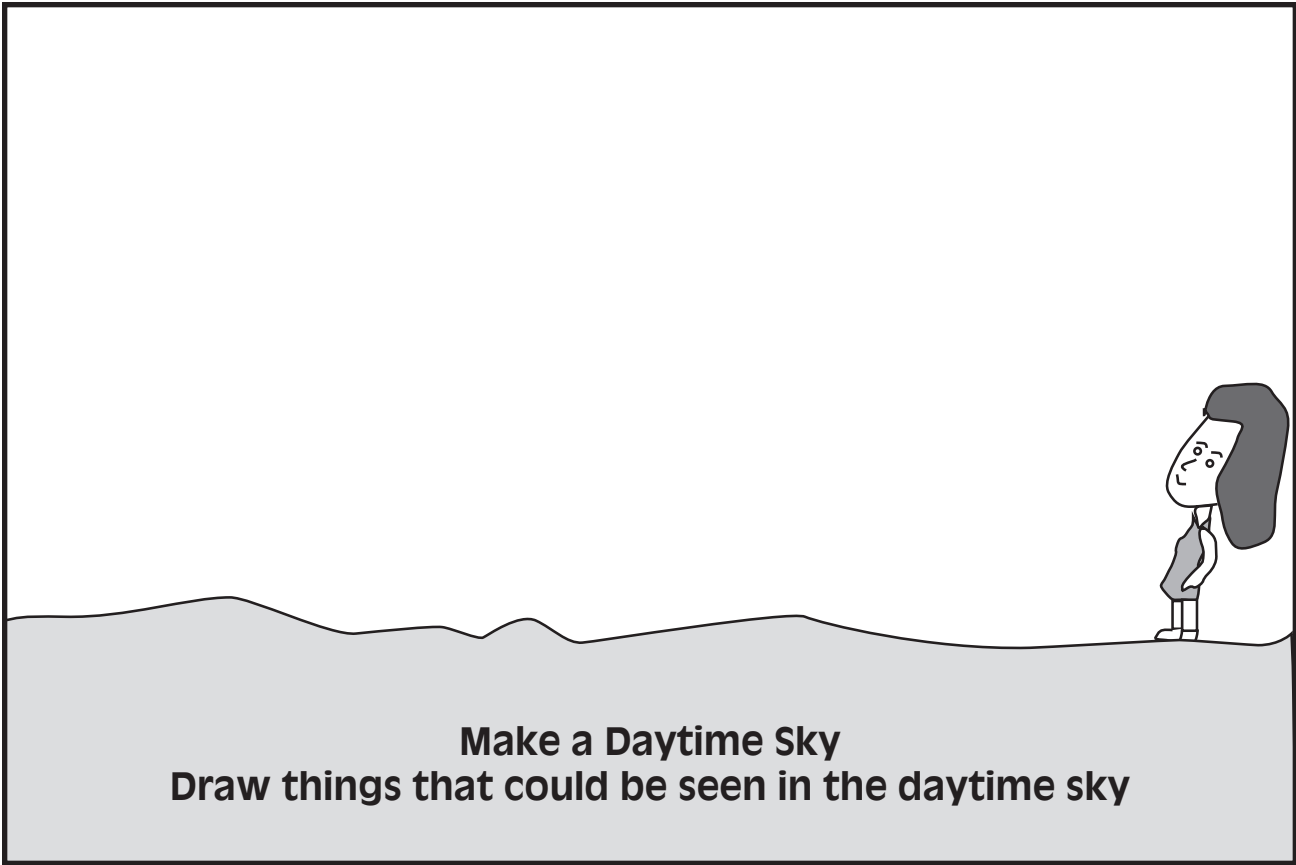

Activity 2: Shapes In the Sky

Grade Levels: K-2

Organization: Individual Task, Small Group

Reasoning Level: Egocentric to Concrete

Activity Strategy: Synthesizing and Open-Ended

Behavioral Objectives: By the end of the lesson, students should be able to:

1. Recognize simple shapes in a complex picture.
2. Locate a group of stars in the planetarium sky that, if connected, would produce a given shape.

Presentation

Distribute the data sheets and ask the class if anyone can find a triangle, a circle, a rectangle, a square, a plus sign, a bow tie, “V”, or “W” in the picture. Tell them to circle the shapes they find and draw a line from the circles to the corresponding shapes at the top of the page. Another option is to have the students use a different color crayon for each shape and color in the shape rather than circle it.

Hand out the second data sheet. Ask the students to make a shape by connecting the dots together. Tell them to find at least three shapes, such as a triangle, a square, and a rectangle.

Invite the students to do the same thing with the stars in the planetarium sky. Divide the class into teams of three or four students, give one cardboard shape to each team. Ask the teams to find their shape in the sky. After a few minutes, ask volunteers to point out their shapes to the rest of the class. Conclude the lesson by encouraging the students to try to find their shapes in the real night sky.

In this activity the students learn how constellations were invented by creating their own constellations. The activity allows the students to develop this concept in easy steps, from observing simple shapes in everyday objects, to imagining shapes marked by stars in the sky.

Materials

For the class

- cardboard cutouts of various simple shapes (circles, squares, rectangles, bows, triangles, etc.)
- flashlight pointer

For each student

- pencil
- copy of the two data sheets (masters on pp. 22–23)
- clipboard or other hard writing surface

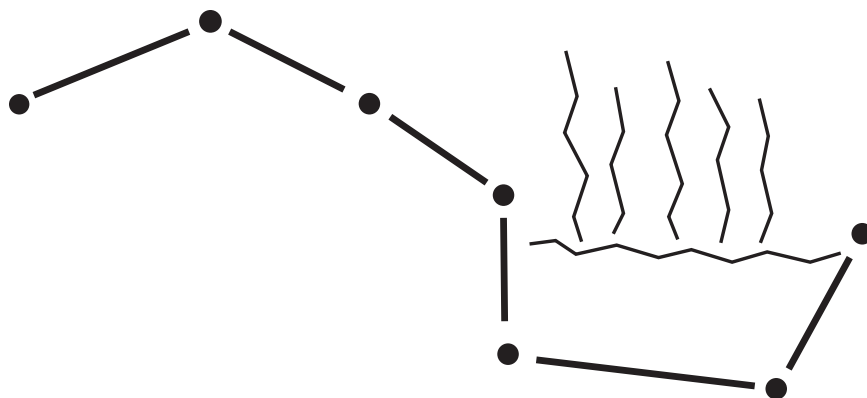

Finding Shapes

Can you find one of each of these shapes in the picture below?

Draw lines from the shapes shown above to the same shapes you find below.

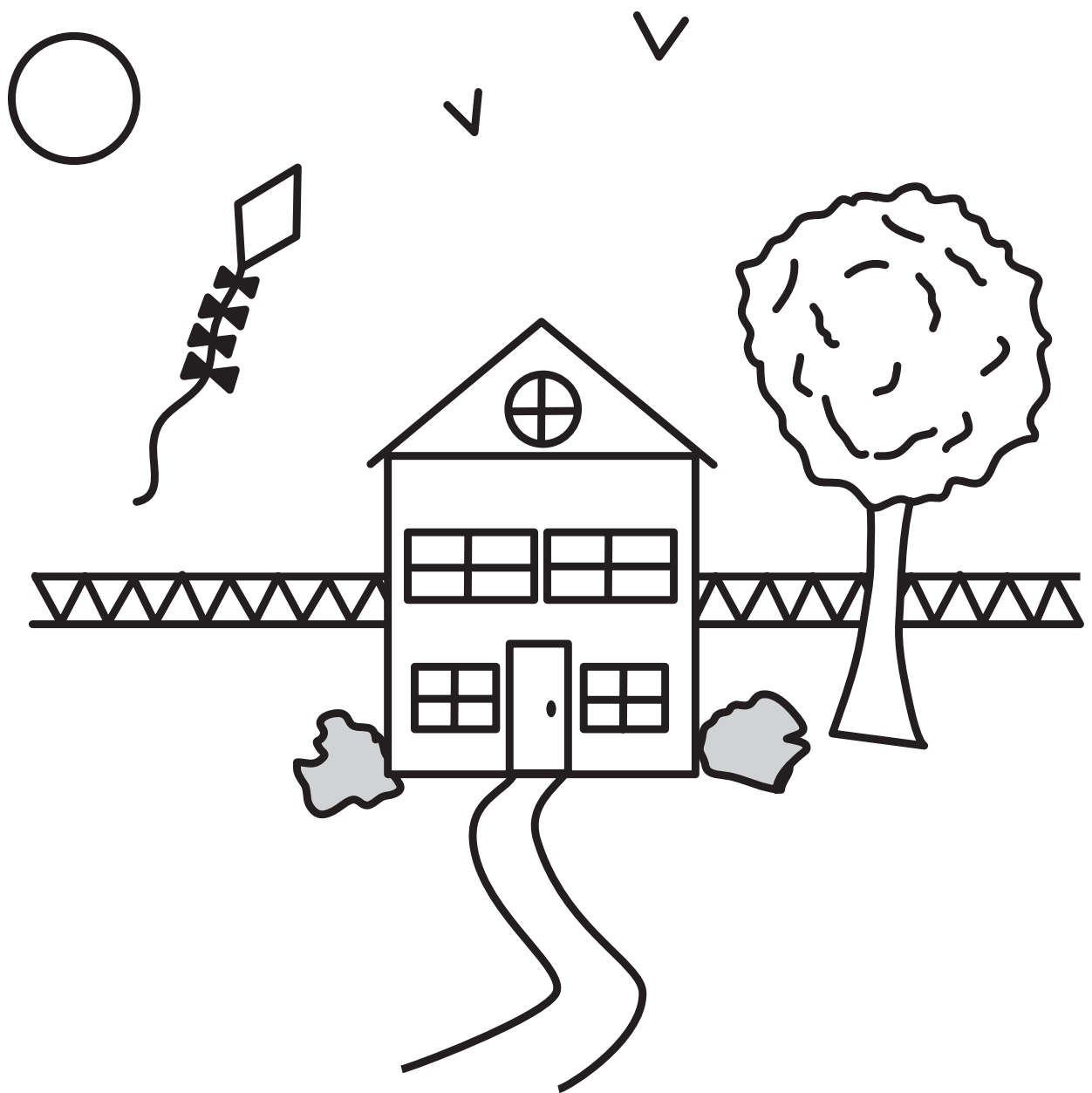

Making Shapes



Can you put the dots together to make one of these shapes???

Use your pencil to connect the dots to make your shapes.

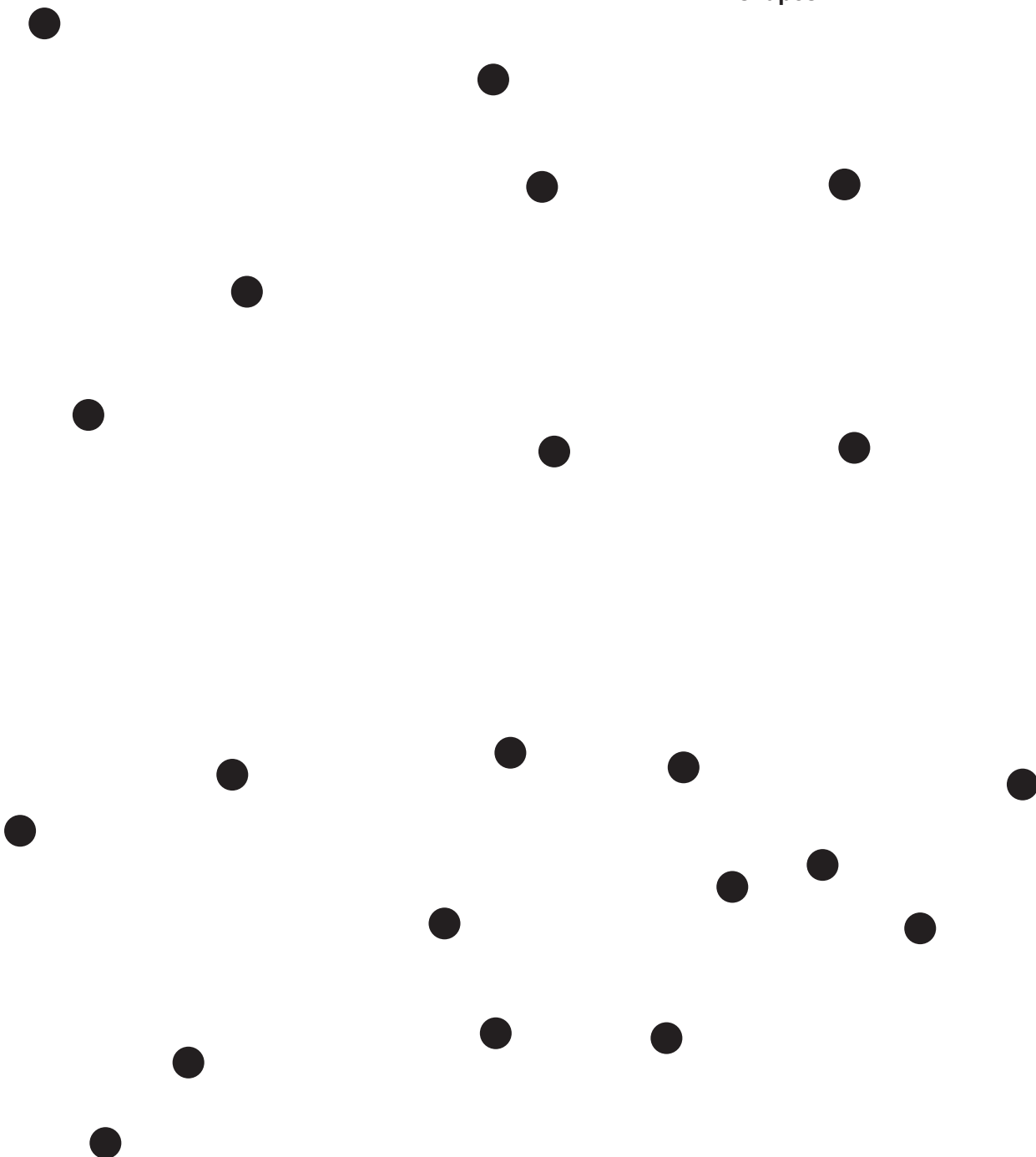

In this activity, students use their own bodies to model the turning Earth to explain why we experience night and day. This is one of many possible activities in which students use their own bodies to model astronomical systems, so they can grasp concepts from their own points of view.

Activity 3: Night and Day

Grade Levels: 1-2

Organization: Socratic, Individual Task

Reasoning Level: Egocentric to Concrete

Activity Strategy: Direct Information—Synthesizing

Behavioral Objectives: By the end of this lesson, students should be able to:

1. Complete, accurately, all four picture problems in the Sun-Earth relative position exercise, by drawing the missing Sun or shadow.
2. Verbally describe the cause of night and day as the result of the movement of the Earth.

Materials

- rotating stool or chair
- a cardboard “Sun face,”
- worksheet (master on page 26).

Presentation

Ask the students why they think we have day and night, and allow them to discuss their ideas.

Ask the students to look at a pretend day sky with the Sun overhead, and then a pretend night sky. (Daily motion is not demonstrated during this first activity—just a comparison of the day sky and the night sky.) Ask

the class, “What happened to the Sun?” Answers may range from “it moved,” to “it went down”, or “it went away,” etc.

Say that “perhaps the Sun went away,” but, while speaking, slowly turn so that the class is now behind you. (A rotating stool works very well for this exercise or simply slowly turning in place.) “Scold” the class for going away. The students will react quite vocally that they did not go away. They are right there. Continue by saying, “Oh! I hear you. How did you go behind me?” Continue with references and definitions of “in front of” and “behind” until the class comes to the conclusion that one can put something behind oneself simply by turning and without the object moving.

Reinforce this concept, as follows. Ask the students to stand and divide the class into two groups. Group “A” on one side of the planetarium is told to “freeze” and then Group “B” makes the frozen students go “in front of” them and “behind” them by slowly turning. Group “B” then takes their turn being “frozen” while Group “A” turns to put the frozen students “in front of” and “behind” them. The kids love changing their “frozen” friends positions and readily see that the act of turning (rotating) can do this.

The next activity is a spin-off from the game “Simon Says.” Tell the students that perhaps this turning can explain day and night and that they can try a game to check it out. The students will use their heads as the Earth and you will pretend to be the Sun. Explain the rules of the game. (One only follows the directions when they begin with the words, “Sun says.”) Ask the class to stand and make it day time or night time on various parts of their head (“Sun says make it day time on your nose”).

In the last activity, the students watch the planetarium sky for a full twenty-four hour period. Explain that the planetarium can make time go by “faster” so that the full day will only take a few minutes to watch. Set the Sun for Spring or Fall and begin the activity with the Sun high in the sky. Explain that as the Earth turns, we will put the Sun “behind us” even though the Sun won’t really be moving. Point out that as the Earth turns, the Sun is seen to our side, then behind us. Explain that when we have put the Sun behind us, it is dark enough for us to see stars but since the Earth keeps turning, even at night, we will soon see the Sun at our other side as we turn around.

Ask a few students to go over and point out where they think the Sun will first be seen in the morning. (If possible, use the motorized Daily motion to produce a smooth change.) The data sheets may be used either at the end of the lesson or in a future review lesson.

Day and Night Puzzle

Look at this picture of the Sun and the Earth. The Sun is missing!! Draw the Sun so that it will shine on the day side of the Earth.

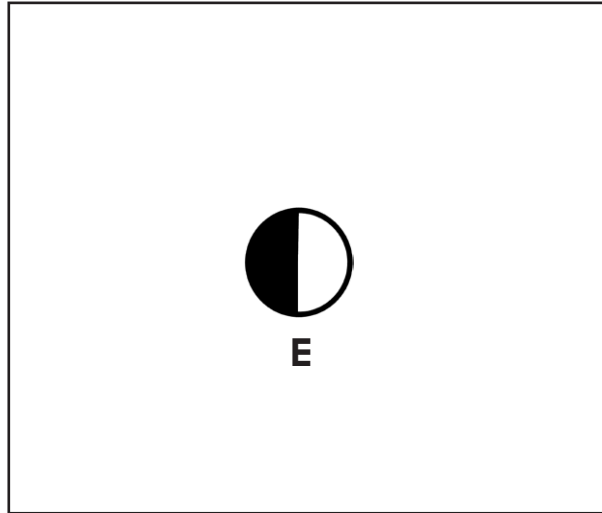
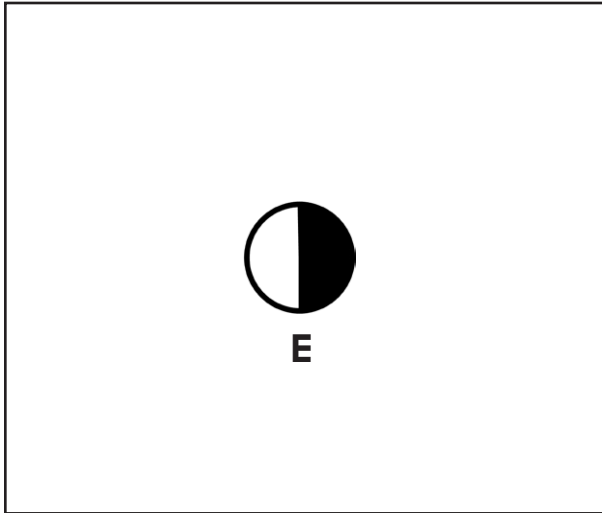

Look at the Sun and the Earth. The night is missing from the Earth. Color in the night side of the Earth.

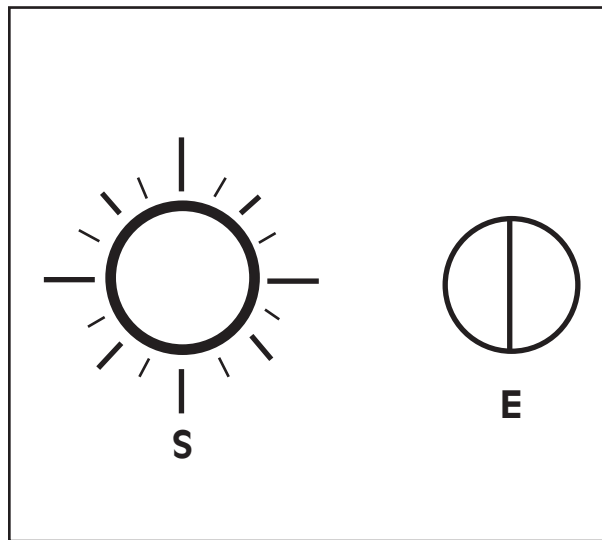
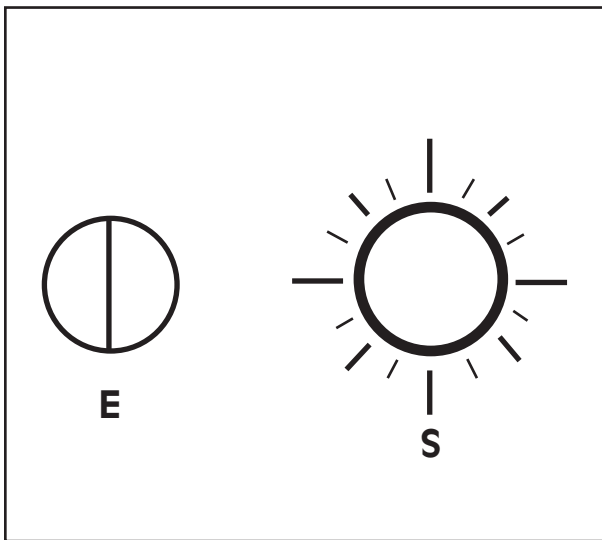

Activity 4: Long Days, Short Days

Grade Levels: K-2

Organization: Socratic, Individual Task

Reasoning Level: Egocentric to Concrete

Activity Strategy: Direct Information; Synthesizing

Behavioral Objectives: By the end of this lesson, students should be able to:

- 1) Explain that all days during the year have the same number of hours (24).
- 2) State which days of the year have more daylight hours, and which days have more hours of night.
- 3) Determine if any day during the year has the same amount of daylight and darkness.

Presentation

To help the students understand the relation between the position of the Sun and the time of day, ask: “Is it morning or afternoon now? Where will the Sun be when it is noon?”

Next, explain that you have set the planetarium projector to reproduce the first day of winter, December 22, and that the students will measure the length of that day by clapping their hands. Turn on the music and daily motion, and demonstrate how to clap with the beats while counting out loud. The students are given a short practice run, and the projector is reset to sunrise. (Cover the Sun when moving the projector backwards, so the students do not think that the Sun can move in both directions.)

As the Sun rises, the students begin to clap with the music, continuing until the Sun sets. For upper elementary and older groups, the activity can be shortened by counting beats until the Sun reaches the meridian and then multiplying by two.

Have the students measure the length of day for all four seasons, selecting the solstices and equinoxes for this purpose since the differences are most extreme on those dates.

As the Sun rises on each date, ask the students to predict whether the day will be long or short. The following questions may help them use their previous experiences to make good predictions: “During your summer vacation,

The purpose of this activity is for the students to compare the hours of daylight in the winter with the hours of daylight in the Fall, Summer, and Spring. It also illustrates how your students can apply their intuitive understanding of the regularity of musical beats to time events in the sky.

Materials

For younger students

- a recording of music with rhythmic beats.

For older students

- use either a metronome or a stop watch.

Set the planetarium projector so it is sunrise on December 22.

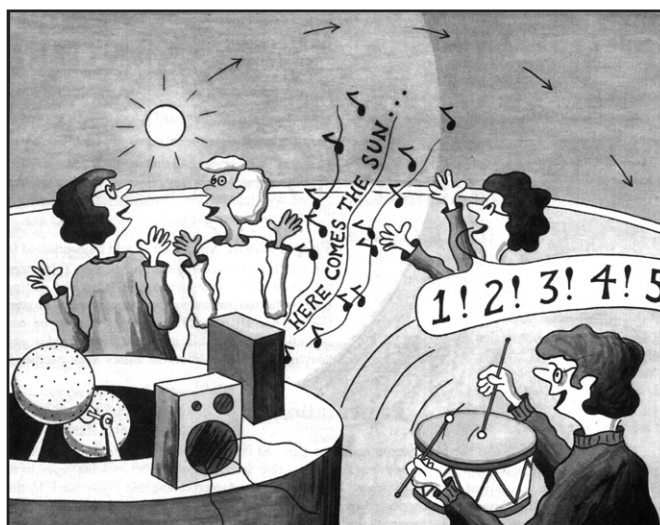

are the days short or long? Just before Christmas, are the days very short or very long? How about in the fall, when you start school—are the days longer or shorter than they are at Christmas time?”

To better understand what we see in the sky, it is very helpful to understand how we perceive light. In this activity, your students use the planetarium environment to learn about their own perception of light, including dark adaptation and color vision. The phenomena will be much more striking and meaningful to your students if they observe the phenomena for themselves before you explain it to them.

Activity 5: Light and the Eye

Grade Levels: 3-5

Organization: Socratic and Individual Task

Reasoning Level: Concrete

Activity Strategy: Direct Information to Synthesizing, and Feeling

Behavioral Objectives: By the end of the lesson, the student should be able to:

1. Describe the reaction of the pupil to different levels of light.
2. List two reasons why many people today have never seen the Milky Way galaxy: sky conditions such as light pollution, clouds, and smog; and eye conditions, such as poor eyesight, or failure to achieve dark adaptation.
3. Describe how our color vision depends on the level of light.

Materials

- two or three large color wheels (2'-3' in diameter)
- two or three flashlights
- one photographic grey card
- cloth or black paper to seal doors and other light leaks
- a star cylinder or star ball that includes a Milky Way, or a separate Milky Way projector. (Such projectors are available from commercial suppliers of planetarium equipment.)

Preparation

This lesson should be conducted in a room that can be darkened completely. Take steps to darken the room by removing bulbs, and sealing doors with cloth or black paper where needed. To start the lesson, all planetarium lights should be on, including the star bulb and coordinate circles and “daylight” lights. Position the Milky Way overhead.

Presentation

Welcome the students to the planetarium and explain that today’s lesson is about how we see things differently when the amount of light is different. Explain that parts of the class will be conducted in total darkness. Explain that for safety reasons, the planetarium director and/or the classroom teacher will have flashlights, so that in case of emergency there will be a source of light.

Explain to the class that you are now going to change the lights in the room for just a few seconds, and during that time you would like them to look around the room and see as much as they can. (Quickly drop the lights to the point that they see only the stars and the coordinates, projected onto the dome. After a few seconds, before the students’ eyes have become dark adapted, bring the lights back to the original level.)

Ask the class what they could see when the room was dark (practically nothing except the stars and the coordinates.) Why couldn’t they see more? (The most common answer will be because there was not enough light.) Explain that there was enough light in the room to see more than they did, so ask them again. (There wasn’t time to get used to the darkness.) Ask the class, how does the eye get “used to” darkness? (The pupil size changes. For older students you might explain that the pupil is simply a hole in the iris. The reason the pupil changes its size is because the iris opens and closes the size of the hole.)

Tell the class that you will now slowly change the lighting. They should pair off and watch each others' pupils to see how they change. Dim the room lights slowly, and then bring the light level up again so the students can watch each others' pupils open, and then close.

Explain that you will again change the light level, and this time they should watch the color wheels and see how their color perception changes.

As the lights fade, there will be a point where there will not be enough light for the cells of the eye that allow us to see color to function. When that happens, all of us will see different colors as shades of grey.

Another approach is to show the color wheels after the lights are lowered and the colors all appear grey. Then allow the colors to appear by brightening the lights. Show the transition to grey again by lowering the lights.

When the lights are completely out, except for the stars and coordinates, ask the students if they have ever heard of the Milky Way. Does anybody know what the Milky Way is? Accept the students' answers. Explain that a long time ago, people called it the Milky Way because they saw this very faint cloud-like milk-white shape that did not change like clouds do. Every clear, dark evening when there was no moon, they could see it. Today, we know it is a group of billions of stars. In fact, all the stars we see in the sky, including the Sun, are part of this same group of stars. If we could see the Milky Way from out in space, it would appear like a pinwheel, and our Sun would be one tiny star, about $3/4$ of the way out from the center.

Ask the students why they think many people have never seen the Milky Way. Their answers may fall into two categories: sky conditions and eye conditions. Sky conditions might include extra light in the sky from the moon, or city lights, or clouds and smog. Eye conditions might include how good a person's eyesight is, or whether or not people have become dark adapted. Explain that you will turn off the coordinates to test the idea that reducing the amount of extra light in the room may make it possible for people to see the Milky Way. Tell the students to look for a faint glowing cloud or train of smoke across the sky. (Fade the coordinates and have someone in the audience point out the Milky Way with a light pointer.)

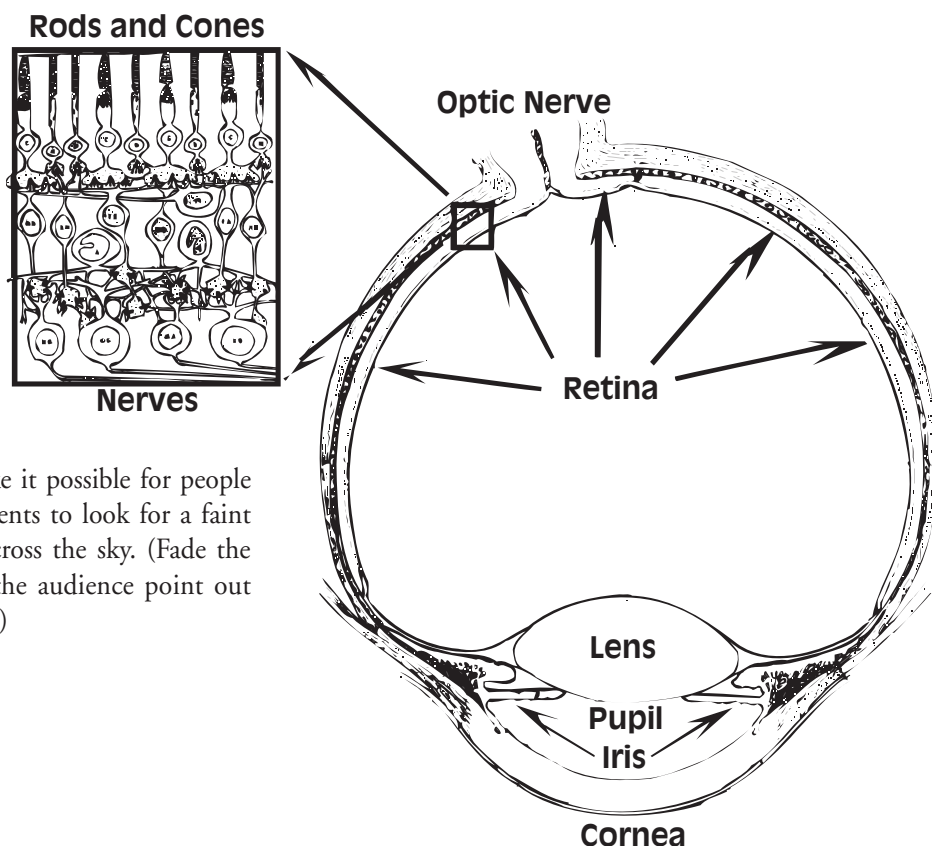

We are now ready to go the final step in our journey and try total darkness. Before we do, let me explain that sight is such an important sense to us, that to take it away will make you feel uneasy. You may want to talk or make noises, or move around in your seat, just to activate your other senses. I want you, however, to be as quiet and motionless as you can be. I would like you to sit very still and think about what it would be like to be so cut off from the world. Think about what it would be like if you were deprived of your sight.

(Turn off all remaining lights. In the dark, ask the students to be very still and quiet, and try to maintain silence for about 15 seconds. Explain that it may be harder than they think. The following section is optional, depending on the behavior of the class.)

Now I want you all to carefully stand up in the dark. Don't move from your seat. Just stand up without touching anything. Move your head around and look at different parts of the room. If some of you think that you are seeing light, turn your head. Whatever you think that you are seeing will go with you! It's called an "after image." Now, first feel for your seat with your hands and then sit down. I am now going to take us to that same level of light that we were at before, but this will be for the third time. (Turn on the stars and coordinates.)

Take a look around. You are now seeing a black and white world. There is no color. (Some students may disagree.) Try looking at this card. (Hold up the photographic grey card, which should have been hidden until now.) Please tell me what color you think it is. (Walk around the room, and ask each student to tell you what color he or she thinks it is. Do not acknowledge if they are right or wrong.)

As the lights come back on, you will see what color this card really is. Be sure to look at the color wheels to see how they appear to change with increasing level of light. (Slowly bring up all lights. Students will see that the card was actually grey.) The color wheels can be compared with the grey card as well.

Ask the students to summarize the lesson with a discussion of the feelings that they experienced in total darkness, and how their vision was different when light level was very low, compared with when it was very bright. You may wish to show a slide with a diagram of the eye and how it works. Point out the **iris** and **pupil**, and the **retina**. On the retina are two types of light-sensing cells. The **cone cells** are sensitive to bright light and colors. The **rod cells** are sensitive to dim light, but do not register color. The **optic nerve** transmits messages from these two kinds of cells to the brain, where we interpret what our eyes see.

You may wish to conclude with some positive statements about the importance of eye care, and the beauty and majesty of the night sky that our eyes enable us to appreciate.

Activity 6: How Do the Stars Appear to Move?

Grade Levels: 3-5

Organization: Individual Task

Reasoning Level: Concrete

Activity Strategy: Direct Information - Synthesizing

Behavioral Objectives: By the end of the lesson, the students should be able to:

1. Describe the apparent motions of the stars in the sky. Some stars appear to rise in the east and set in the west. Some stars appear to circle around the North Star.
2. Explain why the stars appear to move as they do, making reference to the real motion of the Earth (rotation).
3. Given the direction of a star, predict the position of the star if a few hours were to pass.

The purpose of this activity is for the students to observe the pattern of star movements during the night, and then to explain that motion by creating a model of the Earth with their bodies. This activity is similar to “Night and Day,” but is more complex because the students need to visualize how the apparent movement of the entire sky—not just the Sun—results from the Earth’s rotation on its axis.

Presentation

This activity may be performed after instruction on the constellations, when the students can easily identify groups of stars. Assign sections of the audience to watch different groups of stars as you speed up time to illustrate how the stars move during the entire night. If you have several light pointers, one student from each section of the audience can point to their assigned group of stars as the sky moves. Ask the students to share their observations, noting stars rising in the East, setting in the West, and moving in great circles around the North Star. Stars close to the North Star don’t set at all!

Next, stop the motion of the planetarium projector, and invite the students to explain the motion of the stars by pretending to be the Earth spinning in space. Demonstrate how to point at a star directly overhead, and slowly turn in place while watching the stars appear to move in circles. Invite the students to do the same, picking any star directly overhead as their “pole star.” After the students sit down, they share their observations, and volunteers attempt to explain the apparent daily motion of the stars.

You can illustrate these motions with a black umbrella that has some bright yellow stars painted on the inside. Hold the axis of the umbrella so it points at the north star. Show the students how **all** of the stars turn around the north star, and how stars near the rim appear to rise and set.

Materials

- no special materials other than the planetarium projector.

Optional

- a black umbrella with bright yellow stars painted on the inside.



Activities for the School Planetarium

Finally, ask the students to name other spinning objects—wheels, merry-go-rounds, and so on. “What do these objects have in common?” An axis. “Where was your axis pointing when you turned around a few minutes ago?” At a star overhead. “Where is the Earth’s axis pointing as it turns in space?” At the North Star! This notion can be demonstrated with a globe of the Earth in the planetarium.

★ A group of students who easily grasp the relative motion of the Earth and stars might be challenged to predict how the stars would appear to move if we observed from the North Pole of the Earth. After permitting time for discussion about what to expect, the planetarium instructor sets the projector for 90°N. Latitude. The same procedure may be used for predicting how the stars would appear to move when observed from the equator.



Activity 7: Plotting the Paths of Meteors

Grade Levels: 3-5

Organization: Individual Task Reasoning Level: Concrete

Activity Strategy: Direct Information; Synthesizing

Behavioral Objectives: By the end of the lesson, the students should be able to:

1. Identify a meteor in the night sky.
2. Record the path of a meteor on a map of the sky.
3. Using the paths recorded on the sky map, distinguish between two kinds of meteor patterns: (a) a “meteor shower” in which the meteors appear to radiate from a single point in space; and (b) those which appear at random.
4. Explain the reason for the two patterns of meteors.

Presentation

This activity begins with instruction and practice in using the sky map. Be sure to have the students identify a bright star or constellation that will later become the radiant of the meteor shower.

As the constellation finding part of the activity winds to a close, use the pointer to make a bright streak across the sky: “What was that? A falling star? Yes, it certainly could be. Today, let’s use the scientific name for a falling star—a meteor. Meteors are bits of rock and metal that are floating around in space, and fall to Earth from time to time, burning up in our atmosphere as they fall.”

Ask the students to watch the sky very closely, and to record the location and direction of any meteors they see by drawing a long arrow on their sky maps to represent the path of the meteor. Use the light pointer to create three or four random meteors. “To find out what part of the sky the meteors are coming from, use your straightedge to extend the arrow backward on your map. Do these meteors seem to come from any special point, or from different places?”

Next, turn on daylight and explain that we will watch for meteors on a different day of the year, in hopes of seeing more of them. Darken the dome, and turn on the meteor shower projector. Allow time for ten or twelve meteors to be recorded by students, using another color pencil. **“Now extend the arrows backwards with your straightedges. Do they seem to come from one point or from all over? Does anyone have any idea why we saw more meteors tonight, and why they seem to come from one point in space?”**

To explain the radiant of meteor showers, an orrery or slides may be used to show a swarm of meteoroids orbiting the Sun. When the Earth passes through one of these “gravel pits in space” at the same time each year, we observe a meteor shower on Earth. The meteors seem to come from one point in space for the same reason that parallel railroad tracks or telephone poles seem to meet at one point on the distant horizon. This is an illusion called “perspective.”

By recording the paths of meteors on an all-sky map, the students discover that usually meteors come from random directions, but on certain occasions they appear to radiate from a certain point in the sky. They then learn how this observation has helped astronomers figure out how meteors are distributed in space. This is one of many possible activities in which students simulate an important discovery, to learn how astronomers find out about the universe by carefully observing and recording what they see.

Materials

For each student

- one all-sky map—you may use a sky map for the current season (See *Interact! PASS Constellations Tonight* for a complete set of sky maps) or you may use the attached sky map for the month of October when several annual showers occur. For example, you may feature the October 21, Orionid meteor shower which radiates from the constellation Orion.
- a clipboard, straightedge, and two differently colored pencils (any colors will do as long as they can be seen and distinguished in the reading light).
- reading lights so the students can observe meteors and see their sky maps simultaneously.
- a commercial or homemade meteor shower projector (see example design on page 34).
- a light pointer.

Optional

- opaque projector to display students’ data.

Activities for the School Planetarium

Random meteors do not belong to swarms, but float singly in space, and may appear to come from any direction.

It is a nice touch to have some samples of meteorites available for the audience to view or even touch if possible.

[Note: For visiting astronomers, distinguish between meteor, meteoroid, and meteorite: A **meteoroid** is a rock in space; a **meteor** is that same object falling through the atmosphere, sometimes causing the air around it to glow brightly as it is heated by friction; and a **meteorite** is the same object after it has fallen to Earth.]

Meteor Projector Design

The following design for a meteor projector is from the article by Roger Grossenbacher, "Six Special Effects for Your Overhead Projector," *Planetarian*, Vol. 8 No. 2, Summer, 1979.

This meteor projector is mounted on a standard school overhead projector. A motor (from 1/2 to 4 R.P.M.) is mounted shaft down on a swing arm that sits on top of the Fresnel lens. Figure 1 shows how this mounting can be held firmly to the upright arm of your projector. The motor is plugged into the extra receptacle. Figure 2 shows the layout of the two disks needed. These are best cut from manila cardboard (file folders) so the slits can be cut cleanly with a sharp knife. Disk A is fixed in place just above the Fresnel lens of the projector. Focus the projector on Disk A's radial slits. Just above Disk A

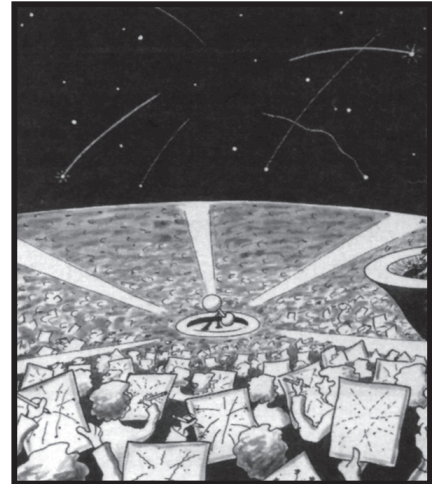

attach a movable Disk B with a metal or wooden hub and a medium speed motor. The numbers of meteors per minute can be made to suit your needs by adjusting the number of slits in Disk B or the motor speed. The slits in Disk B should be radial, but offset so the inner end of the rotating slit cuts the radial slit on Disk A before the outer edge does. This guarantees that the meteors move away from a radiant point. The actual speed at which the meteors seem to move can be varied by using a different pattern on Disk B or by varying the motor speed. The motor must be very carefully positioned over the fixed disk to obtain a realistic shower effect. A simpler version of this projector can be made by omitting the motor and moving the disk by hand.

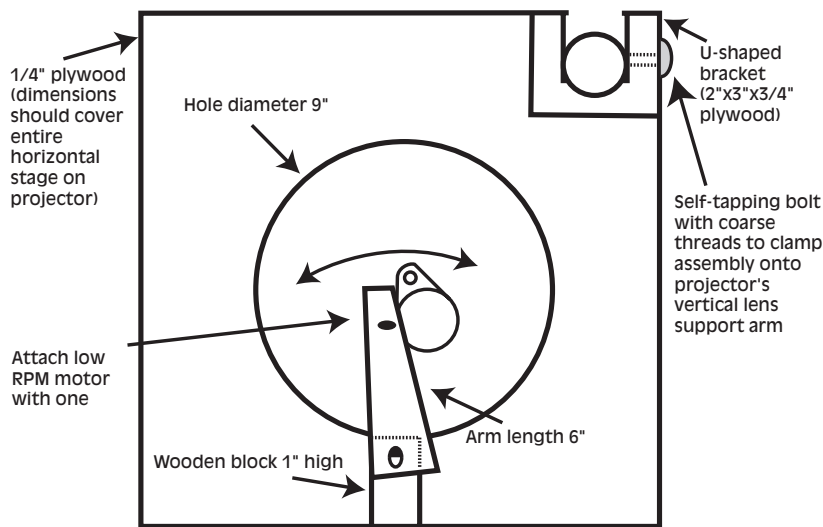

Figure 1

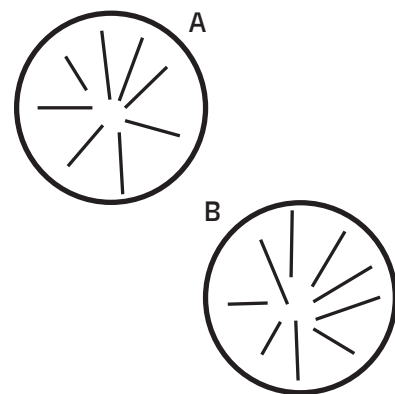
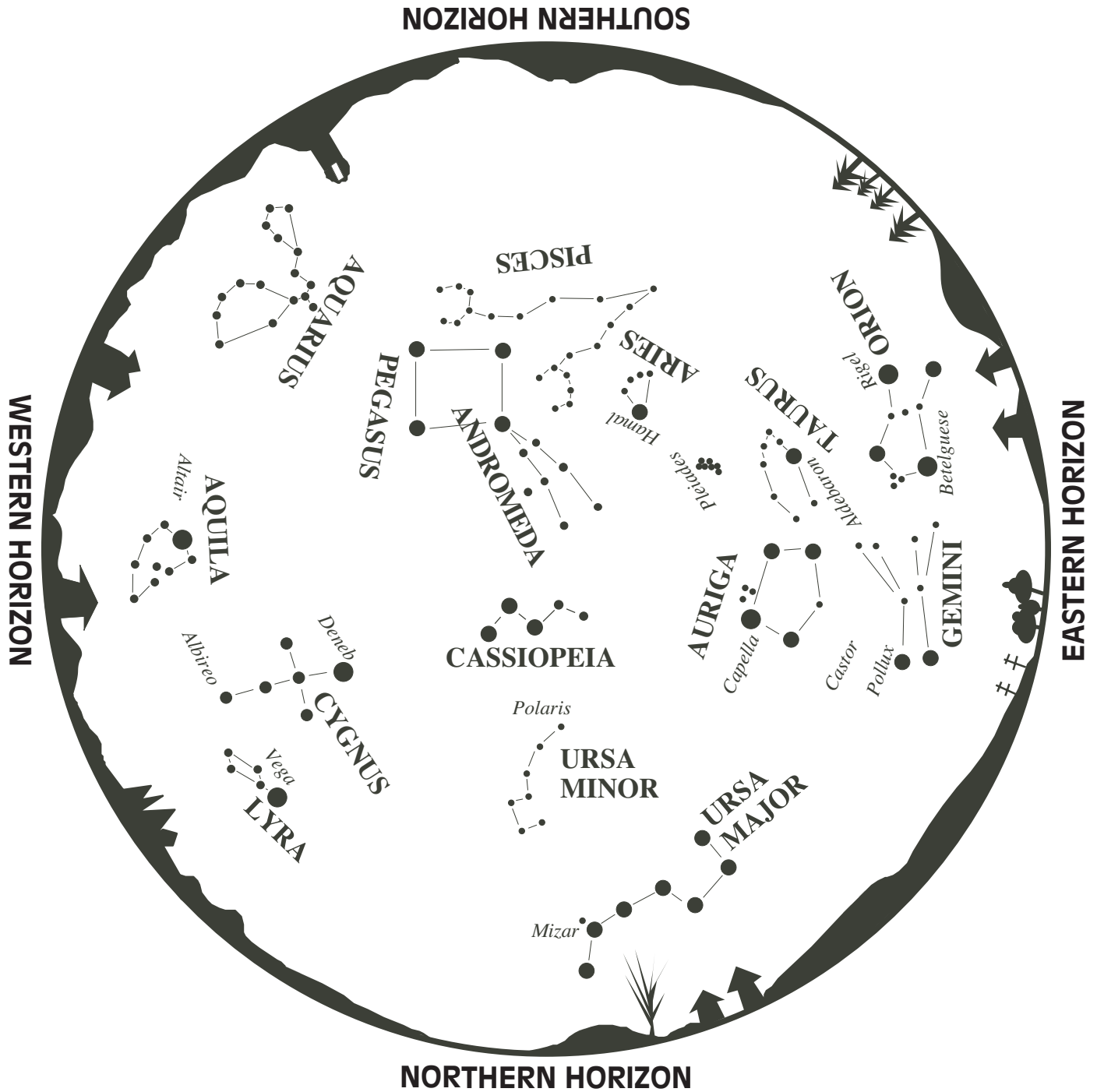

Figure 2

Plotting the Paths of Meteors



Star Map for October
around 2 a.m.

The students observe the relative brightness of stars and discover that there are more dim stars than bright stars. They then invent their own systems to classify stars according to their brightness. They compare their systems and decide on a “standard classification system.” Finally, they learn about the international star brightness classification system adopted by astronomers. A very important aspect of this activity is that the students not only learn about the stellar magnitude system, but also gain some insight into why standard systems are important and how they are developed.

Materials

For each student

- pencil
- surface to write on
- two star map data sheets (pp. 38–39)

For the whole group

- flashlight pointers (preferably one for each small group and each with a different colored piece of plastic over the lens)
- if possible a “mask” for the projector to eliminate the stars that will not be under study. It is possible to construct such a mask out of construction paper or on the STARLAB planetarium to use “Post-It®” style notes directly on the star cylinder.

Activity 8: Measuring the Brightness of Stars

Grade Levels: 3-5

Organization: Small Group

Reasoning Level: Concrete

Activity Strategy: Direct Information; Synthesizing

Behavioral Objectives: By the end of the lesson, students should be able to:

1. Classify stars by their brightness according to a number system.
2. Distinguish some stars as being equal in brightness to others.
3. Notice that there are many more dim stars than bright stars.

Presentation

Ask the class if there are more dim stars or bright stars in the night sky. After listening to a number of responses on this question, show the students the night sky by slowly dimming the lights until they are off. The students will clearly see that there are many more dim stars than bright stars. Ask the class to discuss why they may not always be able to see all of these stars in the sky overhead. (Too many lights.)

In the second activity, ask the students to create a scale to classify the stars according to their brightness. Point out the portion of the sky that they are to work on. (If possible, mask off the remaining stars. This helps the students to concentrate on the chosen section.) Distribute special star maps to the students which contain this part of the sky. Have the students find the constellations that are shown on the map. (The stars on the map should match the position of the stars in the sky but should not give any information on their apparent brightness.)

Assign the students to small groups and give them the task of creating a brightness scale for all of the stars. The brightest star(s) should be labeled with the number 1 on the map and the next brightest one(s) should be labeled with the number 2 and so forth.

Each group must decide how many steps there should be in their scale (should there be three “levels”—ones, twos, and threes, or should there be fifteen levels!) Each team must work out their own process for deciding on a star’s classification.

In the third activity ask the groups to compare their scales and note similarities and differences. (One method is to have each team “represent” an observatory from a different country. They are meeting at an international convention to compare their systems. The “Director” of each observatory briefly presents their system and then the similarities and differences between the various systems. Ask the students if they can decide which is the best system. “Voting” is usually mentioned as one solution, but ask the students if they can come up with other methods as well.

Ask the students if they can think of some type of device, some new technology, to help with the problem. After the students discuss their ideas, you might add that **photography** is often used as a means of comparing brightness of stars. Another method, called **photometry**, uses a light meter like that used in cameras, to measure the brightness of stars.

Conclude the lesson by giving the students a copy of the “official” magnitude scale for the stars they worked with and have them compare it to their versions.

Optional

Make transparencies of the star brightness scale (bottom of page 39; multiple copies on this page) for students to place on their worksheets for easier identification of star brightness.
 [suggestion by Judy Shubkagel, POPS leader—summer of 1992]

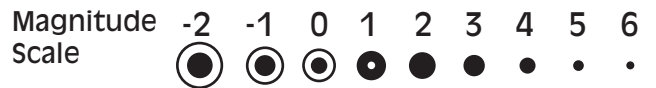
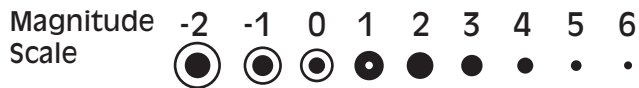
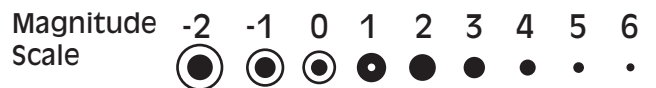
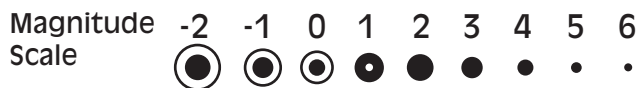
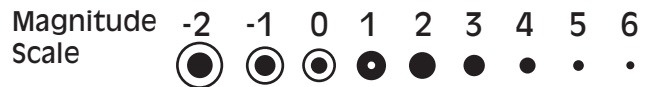
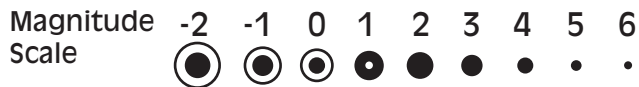
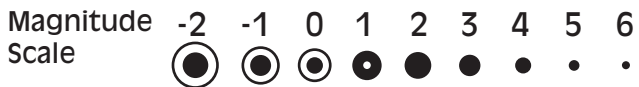
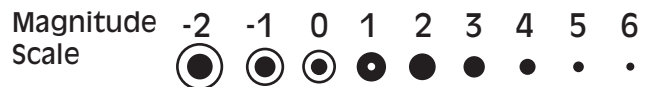
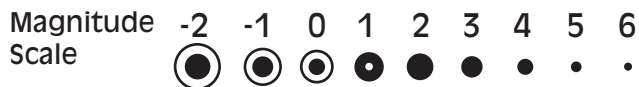
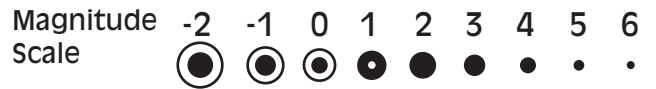
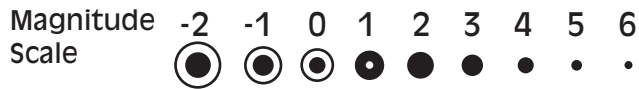
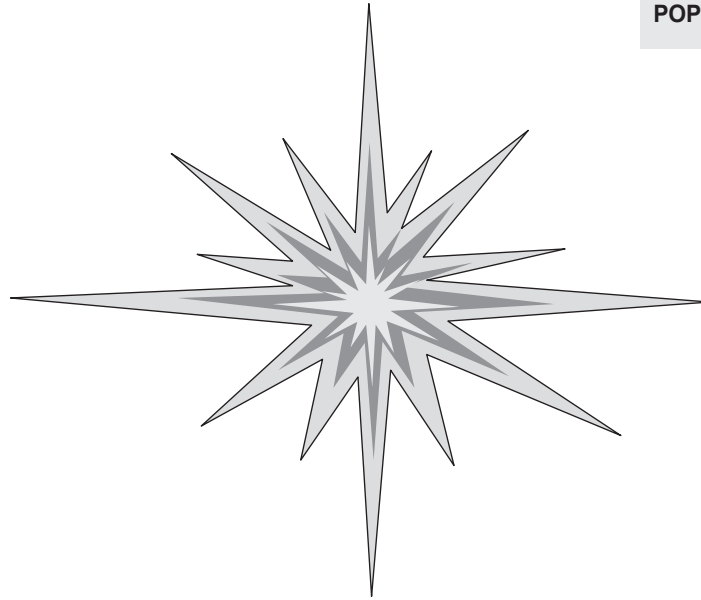

Brightness of Stars — Worksheet 1

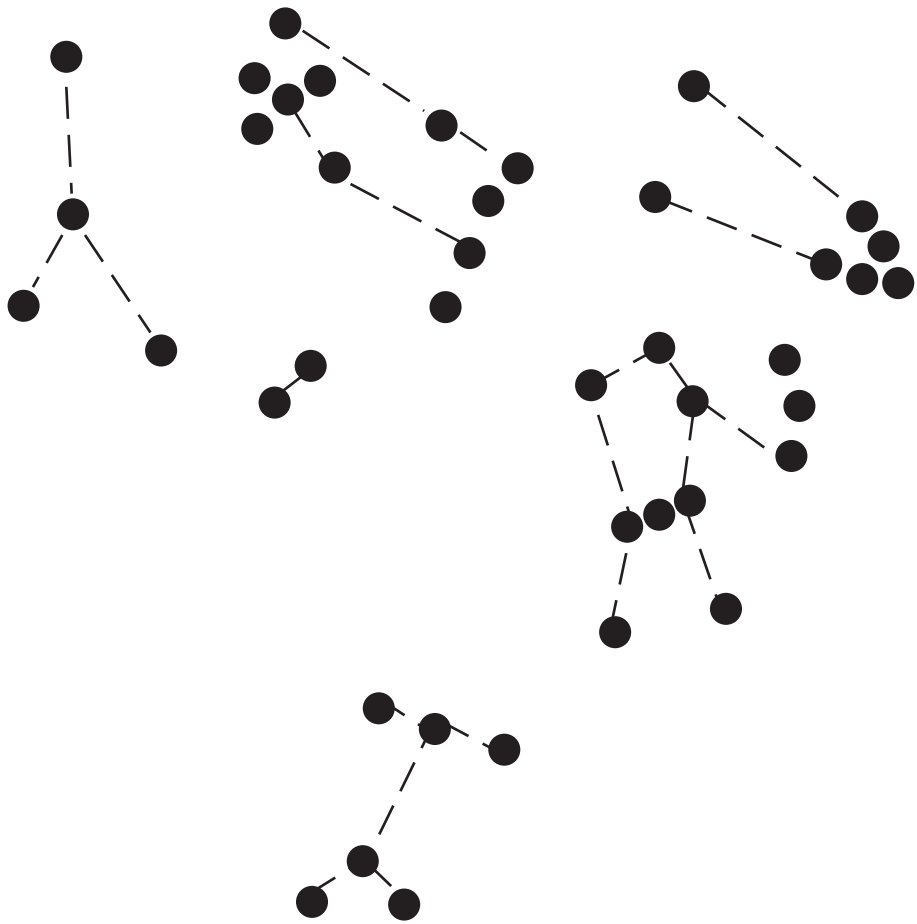

Brightness of Stars — Worksheet 2

Apparent Magnitude

This is a way of telling how bright a star appears to be to us on planet Earth. Two factors go into this figure:

- 1) how much light the star is really producing, and
- 2) how far away the star is from us on planet Earth.

Below is a star chart showing the accepted Apparent Magnitudes for the stars you worked with on Worksheet #1. Compare your scale with this scale. How do you think astronomers today would settle disagreements over how bright a star appeared to be to them?

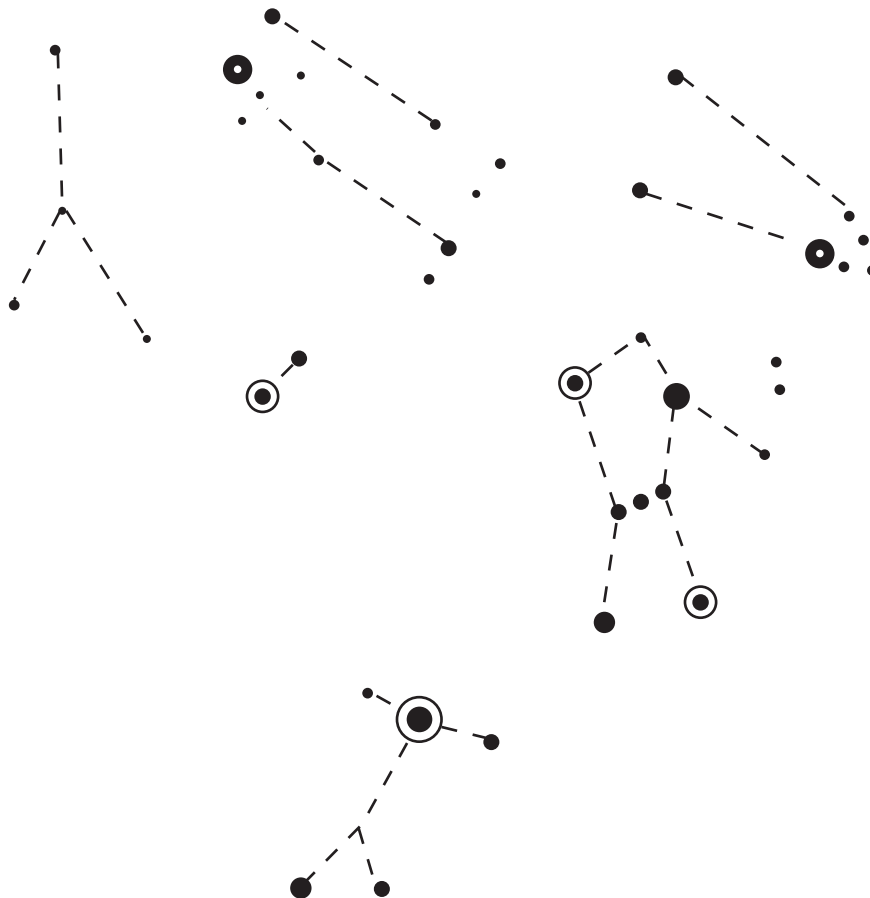

The Apparent Magnitude Scale: -2 -1 0 1 2 3 4 5 6

The students simulate the work of variable star observers by comparing the brightness of an unknown variable star with surrounding stars of known magnitudes. They discover its characteristic light curve and brainstorm different ideas for what might have caused the curve. They think about how to test their various hypotheses, and finally learn about the “eclipsing binary” hypothesis for this kind of light curve. Student interest is maintained because they collect the data and try to explain it themselves, before learning about the way such phenomena have been explained by astronomers.

Materials

- a slide showing five stars labeled with magnitude numbers 1 through 5 [Figure A, projector #1].
- a projector to place a variable brightness dot of light in Leo with similar fuzz and color to the planetarium stars. Any single or multiple slide projector can be used as long as its brightness is variable. A piece of aluminum or plastic serves as a slide, and a hole is drilled in the slide to make a star of average diameter. [Figure A, projector #2].
- a brightness vs. time graph, clipboard, and pencil for each student [Figure B]; and 4) (Optional) a set of slides that will help the students apply the binary star model to their observations [Figure C].

Activity 9: Observing a Variable Star

Grade Levels: 6-9

Organization: Individual Task and Socratic

Reasoning Level: Concrete to Formal

Activity Strategy: Synthesizing

Behavioral Objectives: By the end of the lesson, the student should be able to:

1. Measure the brightness of a variable star by comparing it to standard stars nearby.
2. Record the brightness of the variable star for several nights on a brightness versus time graph.
3. Discuss the star’s “light curve” by comparing observations with other students.
4. Interpret the light curve by inventing different models for the star and seeing how the models fit the data.

Presentation

Point to a star in the constellation Leo and explain that “Two photographs of this star, taken on different nights, show that it seems to vary in brightness compared with the surrounding stars. It’s our job, as variable star observers, to find out if the star is really changing in brightness, and if so, how it changes.”

So that the students can measure the brightness of the star, project numbers 1 through 5 next to certain stars in the constellation Leo. The numbers correspond to the approximate magnitudes of these stars. Invite the students to estimate the brightness of the suspected variable by deciding which numbered star is closest in brightness to the variable.

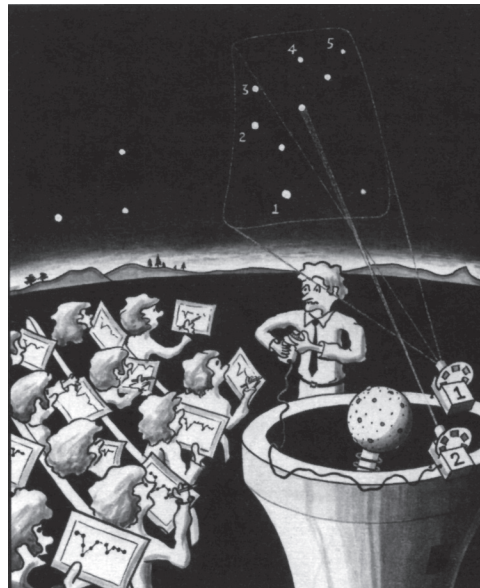

After the students understand how to measure the brightness of the star, bring up daylight and hand out brightness vs. time graphs. Demonstrate how to use the graph by projecting a slide which shows how one person’s observation would be plotted.

Figure A. Arrangement of materials for “Observing a Variable Star.”

After giving the students an opportunity to ask questions about the procedure, invite the students to compare the variable with the surrounding stars and make a final estimate of its brightness for the first “day.” While turning up daylight so the students can graph their first observation, reset the brightness of the variable star projector (Figure B). Then dim the daylight for the second observation. The students estimate the brightness of the variable, and the lights are turned up again so the students can add another data point. This process continues until the 12th “day.” By setting the dot projector in a predetermined pattern, you can simulate any desired light curve. The sequence of magnitudes: 1, 1, 3, 5, 3, 1, 1, 1, 2, 3, 2, 1—will result in the light curve pictured in Figure B.

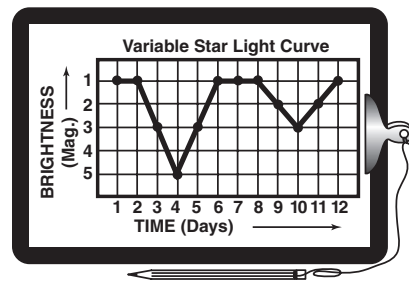

Figure B.
Student's Data Sheet

When the students are finished, they draw a line through the plotted points and compare with their neighbors' results. Help the students describe the light curve by asking leading questions: “Are there any dips in brightness? How many of you find the first dip to be as low as star 2? 3? 4? 5? I notice that nearly all of you said 4 or 5. What do you think we should agree on as the best estimate for the brightness of the first dip?”

After the students have discussed the shape of the light curve, invite them to explain it. Often students mention clouds or pollution that might cause the changes in brightness. Some students suggest that the star itself might be changing, or that one or two large planets might be orbiting it, and blocking off some of the light now and then. For each suggestion, the instructor asks how the idea might be tested. Clouds or pollution, for example, might be expected to affect all of the stars in the region and be present only irregularly. A star's intrinsic brightness could vary regularly or irregularly, and the large planet model would predict a pattern of identical dips to repeat. If there is time, the students can continue observing for another twelve days and discover that the pattern of alternating deep and shallow dips is repeated, or the instructor can just say that the pattern has been studied by other astronomers who find it repeats over and over.

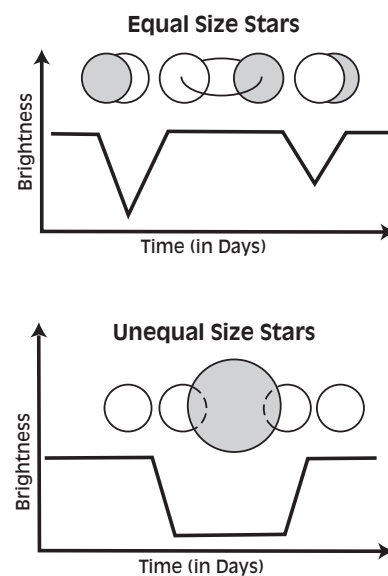

Figure C. Sample slides for interpreting “eclipsing binary” light curve.

Sometimes, the students propose the eclipsing binary star model—that two stars are circling each other. If the students do not generate this possibility, you can suggest it and show drawings to illustrate what we could infer if we assume that the variable dot of light we see is really two stars very close together. The difference between depths of the two dips, for example, can be explained as due to the difference in brightness between the two stars. The sharpness of the dips can tell us about the relative sizes of the stars, and the time between the dips can tell us how long it takes for the stars to circle each other (see Figure C). The students can measure each of these quantities from their own data.

Comments: We have used this activity satisfactorily in a single-visit program, (“Black Holes and Other Strange Stars”) for junior high to adult audiences, and with gifted youngsters in upper elementary school. The activity is particularly valuable because amateur astronomers contribute seriously to the progress of astronomy by keeping track of variable stars, through the American Association of Variable Star Observers.

The variable star light curve pattern in Figure C is actually quite unrealistic. Changes have been exaggerated to make measuring the curve easy for beginners. Typical light curves for eclipsing variables show changes of tenths or hundredths of magnitudes, not several magnitudes. Since the magnitude scale is also logarithmic, there are complications in finding individual magnitudes. A simple totally eclipsing binary could not have the pattern shown—the second dip would be much shallower.

In this activity your students learn how to use a blink comparator. This is an instrument which is used by astronomers to detect a moving object, such as a planet or asteroid, in a field of stars. It is a nice example of an activity in which the operating principle of an important astronomical instrument is communicated through a simulation in the planetarium.

Materials

- two slide projectors
- two slides of the same star field taken an hour, week, or a year apart revealing the motion of an object such as an asteroid or planet.



Activity 10: Using a Blink Comparator

Grade Levels: 6-9

Organization: Group Meeting

Reasoning Level: Concrete to formal

Activity Strategy: Synthesizing

Behavioral Objectives: By the end of the lesson, the student should be able to:

1. Identify a starlike object that has moved in the time interval between two photographs.
2. Describe how a blink comparator is used to detect astronomical objects such as asteroids and planets that move with respect to the stars.

Preparation

Load the two slides in the projectors, and adjust them so the star fields are superimposed. The blinking action, in which you alternately block light from the two projectors, can be done with your hand or with a motor operated shutter. (This device is described in “Blink for a Nova” by Ben Mayer, *Astronomy*, 6, 34-37, May, 1978.)

Presentation

Begin by introducing the problem—to discover new asteroids by observing their motions. The problem is that asteroids look exactly like stars! Describe the “blink comparator” by pointing out the two slide projectors, and explaining that each projector shows a photo of the same part of the sky, but taken at different times.

Turn on both slide projectors, blocking one of them with your hand. Ask the students to watch carefully for changes as you cover the first slide projector and expose the second. Usually, visitors will not be able to see any change at this point, so try it again, switching a little faster. Finally, when you switch or “blink” back and forth rapidly, the students will easily be able to detect movement of a single asteroid, even among a field of several hundred stars.

The blink comparator has been used to identify hundreds of asteroids, supernovae, and even some of the outer planets. Instruments that work on this same principle were used to search for “Nemesis,” a small dim star that might possibly exist as a companion to the Sun.

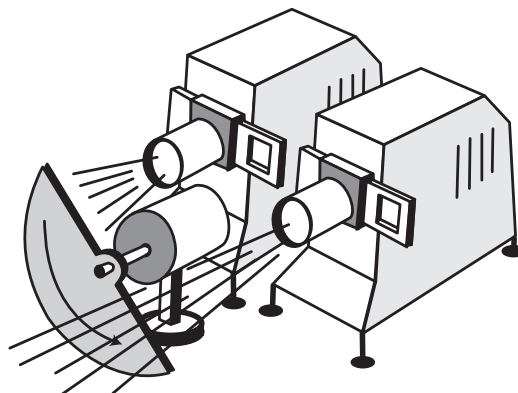

Activity 11: Mythology: Explaining the Unexplainable

Grade Levels: 6-9

Organization: Socratic and Small Group

Reasoning Level: Concrete to Formal

Activity Strategy: Synthesizing and Feeling

Behavioral Objectives: By the end of the lesson, the student should be able to:

1. Define the term “Mythology” in their own words (it should be explained as being more than just fiction.)
2. Create in small groups, a fictional story to rationally explain a given situation (i.e. create a make believe myth).
3. Describe some of the problems of communication when there is no written language, so that myths must be transmitted orally.

Presentation

Explain to the class that throughout time, people have tried to make sense of the many strange things that they have seen in the sky. Sometimes, people have tried to relate real or imagined events on the Earth to what they see in the sky—the Sun slowly sinking below the horizon each evening; stars that appear to move among the other stars; the moon growing large and then shrinking again.

To explain these and other phenomena, they used the knowledge that they gathered during their lifetimes and the lives of others before them. This attempt at explaining the otherwise unexplainable is the foundation of mythology. And mythology, as it attempted to explain natural phenomena, was the forerunner of modern science.

Show the class a photograph of a solar eclipse and ask them how such a phenomenon might be explained by people long ago. Ask them to try to construct their explanations using knowledge that was available to people long ago. After considering the various answers, explain that many cultures came up with the idea that some celestial creature, a dragon perhaps, was eating the Sun! This may sound funny to us today, but keep in mind that to the people participating in the myth, this was the truth.

Many times people confuse *myths* with *folktales*. Both involve “stories” from people in the past and both today are seen as works of “fiction.” A folktale (e.g., Cinderella or Snow White) is known to be a make-believe story, while a myth tries to explain something that was believed to be true. A myth is different than a folktale in two important ways:

1. To the people who believe and support the myth, it carries with it the full authority of truth, even to the extent that men and women are willing to die in its name. It can evoke intense commitment and total belief in its truthfulness.

Literature and astronomy are merged in this activity patterned on the popular game “gossip.” The aim of the activity is to illustrate how myths — the forerunners of scientific explanations — were created thousands of years ago, and how they were modified over the centuries. This is a very creative, highly motivating activity because students have an opportunity to make up stories, and to see how they change when retold many times in succession.

Materials

- writing paper, pencils, clipboards or other writing surfaces for each student,
- two or three flashlight pointer(s)

Optional

- slides, photographs, or drawings depicting various celestial phenomena that were explained by myths, such as a dragon eating the Sun to explain a solar eclipse.



2. Although myths can change with time, the central structure of the myth is usually an attempt at explaining some actual event or phenomena.

Invite the class to create a myth in keeping with this philosophy. Divide the class into small groups of four or five people. Explain that you are going to show them the sky and tell them of some events as they watch. Their challenge is to listen to the events, make note of the sky, and then to create a "myth" to explain the situation. Create teams of 3 or 4 students to work together.

Set the planetarium for a summer sky and turn the room lights completely off. In the darkness, relate the following instructions to the class: "You are part of an ancient culture that suddenly experienced a very long and severe drought. This drought lasted several months during the summer, when the Milky Way is seen high overhead. (Point out the Milky Way.) The constant cloudless nights afforded you a clear view of the sky. After many months the rains finally came and the drought ended."

Bring the lights up. Distribute the paper and pencils. Circulate among the groups checking on progress and offering assistance as needed. Review the myths created by the small groups and select one to use in the communication activity. Before proceeding with this activity, you may ask for volunteers to read two or three of the other myths. (Do not read the selected myth aloud at this time.)

Explain that the myths we hear today may not really be the same as the original myths. To help students to see how this happens, select four volunteers who did not hear or create the selected myth. Send three of the volunteers out of the planetarium. Give the remaining student volunteer the following instructions and then have one of the students who created it read the selected myth: "The speaker will tell you the myth once. You are not permitted to ask questions or to have the myth repeated. Try to remember as much of the myth as possible. After listening to the myth, you will be asked to tell it to someone else."

As the myth is read, the entire class is told to listen carefully as each person retells the myth and to note any changes that occur as the myth is transmitted. Once the first volunteer has heard the myth, the second volunteer is brought into the planetarium and given the same instructions listed above. The first volunteer recites the myth aloud so that the second volunteer and the whole class can hear it. The next volunteer is brought inside, and so forth until the last volunteer has heard the myth. The last person should retell the myth to the entire class. Be prepared for lots of laughter as the myth is changed each time it is retold.

Finally, the original myth should be retold for all of the volunteers and other students to hear. Lead the class in a discussion on the changes that occurred in the oral version. “Did rational explanations become irrational? How did influences from our own culture cause changes? How reliable can present-day versions of ancient myths be?” After recapping the important points raised by the class, encourage the students to continue to study myths from ancient cultures and the celestial phenomena that generated many of them.

Conclude by asking your students to discuss the similarities and differences between myths and modern scientific theories. Some points that students have made in this discussion include the following ideas. **Similarities:** Myths and theories are attempts to explain what we observe. Both are thought to be non-fiction. Both change, at least to some extent, when other people try to describe or interpret them. **Differences:** Myths were thought to be absolutely true, while today we believe scientific theories only in so far as they are supported by evidence, and not replaced by better theories. Theories are always recorded in writing, and sometimes in mathematical symbols. Modern theories do not involve superhuman powers or magic, as myths often do.

Optional

During the Create-a-Myth activity, you may wish to offer the class an example of a previously created myth such as this.

One day, many years ago, the Earth became hot and dry. Water no longer existed on the Earth. Life was very difficult for those who lived at that time. The people often prayed to the Mother Earth to quench their thirst, but these prayers were not answered because of the evil intervention of Malu. Malu removed all of the water from the Earth, stored it in the heavens, and prevented the prayers of the people from reaching the Mother Earth. But one night while Malu rested from all of this evil, Little Ninu prayed fervently to Mother Earth and with this soul-wrenching prayer, the truth was finally revealed to the Mother Earth. In anger, she banished Malu and sent her messenger, Ganzu, down the heavenly river to bring water again to the scorched Earth. (We see the heavenly river today as the Milky Way, and Ganzu as Cygnus the swan.)

Educational research has shown that understanding why it is warmer and the days are longer in the summer than in the winter is very difficult for students. This activity approaches this subject by having the students observe and record the Sun's path through the sky in each of the seasons. At each step they predict what they think they will observe next. They then try to explain why the Sun's path varies throughout the year. Finally, they use a model Earth ball to visualize how the tilt of the Earth's axis causes the variation in the Sun's path with the change in seasons.

Materials

- markers to indicate the predicted position of sunrise/sunset on the dome (these could be pieces of cardboard with paper clips on the back for planetariums with coves or sheets of paper hung with masking tape or "Post-It®" style notes)
- a white light in the center of the planetarium to represent the Sun, an Earth globe that will turn on its axis, and a small paper or toy figure of a person with a movable arm (see illustration) fastened to the Earth globe.
- a meridian line projector for measuring the altitude of the Sun at noon. In portable planetaria, you can tape marker papers every 10 degrees along the meridian by partly deflating the dome until the zenith can be reached, taping the 90° mark there, and slowly reinflating the dome while putting up markers at 80°, 70°, and so forth along an imagined meridian line towards the southern horizon. Extreme accuracy is not critical.
- North, East, South and West horizon markers (optional: mark every 10° in between those markers). The best pattern is having East and West each be marked 0°, with North and South being 90°.
- data on the length of day at solstices and equinoxes at your latitude. This may be found in newspapers or observers' handbooks with sunrise and sunset listings.

Activity 12: The Reasons for Seasons

Grade Levels: 6-9

Organization: Individual Task

Reasoning Level: Concrete to Formal

Activity Strategy: Direct Information - Synthesizing

Behavioral Objectives: By the end of the lesson, students should be able to:

1. Describe the apparent daily path of the Sun during the four seasons.
2. Explain why the Sun's daily path changes during the year.
3. Predict the rising and setting point for the Sun for different seasons.
4. Explain why days are longer in the summer and shorter in the winter.

Presentation

Engage the students in a discussion about where we see the Sun in the sky. Ask if the Sun is always at the same height (altitude) above the horizon at noon throughout the year. Ask where the Sun rises and sets, and whether or not the direction of sunrise and sunset stays the same every day, or changes throughout the year.

Tell the students that they will be collecting data on the Sun's apparent path, including not only the height at noon, but also the length of day and the position of sunrise and sunset throughout the year. Hand out the data sheets. Tell the students that they will have to estimate the sunrise and sunset directions by looking at the N, S, E, W markers on the horizon. In addition, they will need to estimate the Sun's position at noon by observing its altitude (in degrees) between the zenith and the horizon (point out the meridian line).

Show the Sun's path for the 1st day of summer, fall, winter, and spring (Use the equinoxes and solstices to represent the seasons since the most extreme paths of the Sun are observed on those dates.) In each case, have the students *predict sunrise, noon, and sunset* before showing the Sun's path on that date. As the Sun traverses the sky on each of those dates, the students mark its positions at sunrise, noon, and sunset on their data sheets (Reasons for the Seasons Worksheet).

For each student

- a pencil
- a copy of the worksheet, p. 48.
- a clipboard or other writing surface
- a 3" polystyrene "Earth ball" on a pencil or stick with a pin or piece of toothpick stuck in at about latitude 45° (see diagram next page).

On each date, have student volunteers mark the positions of sunrise and sunset on the cove or side of the dome with a “Post-It®” or other method. (Optional: You may extend the chart on the worksheet to include columns for your students to write sunrise and sunset positions, or have the students verbally describe sunrise and sunset positions on a chart on a separate page.) After each day, announce the hours of daylight for that day and have the students write that number of hours in the table on their data sheets.

After all the dates are completed, ask the students to draw the Sun’s path for each date from sunrise to sunset. The path for each season should include a smooth curved line through the sunrise point, noon position, and the sunset point.

Ask the students to study their charts and see if they can suggest a reason to explain these changes. After a discussion of possible explanations, tell the class that a long time ago, astronomers found out that the reason that the Sun appears to take such a different path through the sky in different seasons is due to the way the Earth is tilted as it travels around the Sun. Using the white light as the “Sun” and the Earth globe, demonstrate that the north pole of the Earth always points towards the north star, or Polaris. Holding the globe, walk around the Sun, keeping the north pole of the Earth pointed towards the north star. Point out that as the Earth travels around the Sun, the north pole of the Earth’s axis is tilted towards the Sun in the summer, and away from the Sun during the winter. Tape the small figure of a person to the globe (at your home latitude) and point out how the person would see the noon Sun higher in the summer and lower in the winter. This can be made more apparent if the figure has a movable arm to point toward the Sun. In the summer, the arm points high up, while in the winter, the arm points much lower.

Your students can see the model better if you hand each student an “Earth ball” with a pin representing a person on it.

1. Have the students tilt their balls towards the Sun (summertime), rotate it until the person is experiencing noon (closest to the Sun), If the person pointed towards the Sun with his arm, would he be pointing high or low in the sky? Do the same for the wintertime Sun at noon. Would he be pointing his arm higher or lower?
2. Have the students slowly rotate their Earths and see the pins move alternately from night to day. They can see that summer nights are shorter than winter nights.
3. Another interesting observation in this model is comparing the length of the shadow of the pin at noon in different seasons.

Finally, have your students use their observations of the sky and Earth model to explain why it is hotter in the summer than in the winter, even though the Earth is slightly closer to the Sun in the winter time. One expla-

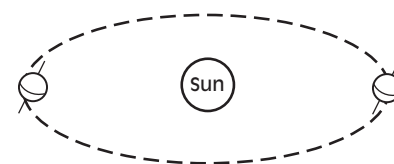
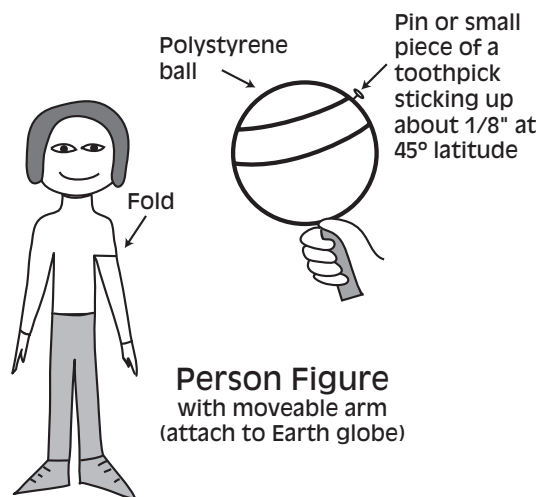

The Earth’s axis of rotation is tilted by $23\frac{1}{2}^\circ$ with respect to the Earth’s orbit around the Sun.

nation they may think of is that the days are longer in the summer, allowing the Earth to heat up more. That is correct, but it is only part of the story. Another reason is that when the Sun is higher in the sky, its light is more concentrated on given areas of Earth.

To illustrate, you may try one of the ideas on page 49 for a follow-up session.

Name _____

Date _____

The Reasons for the Seasons—Worksheet

Season	# Hours of Daylight	Noon Position
Autumn		
Winter		
Spring		
Summer		

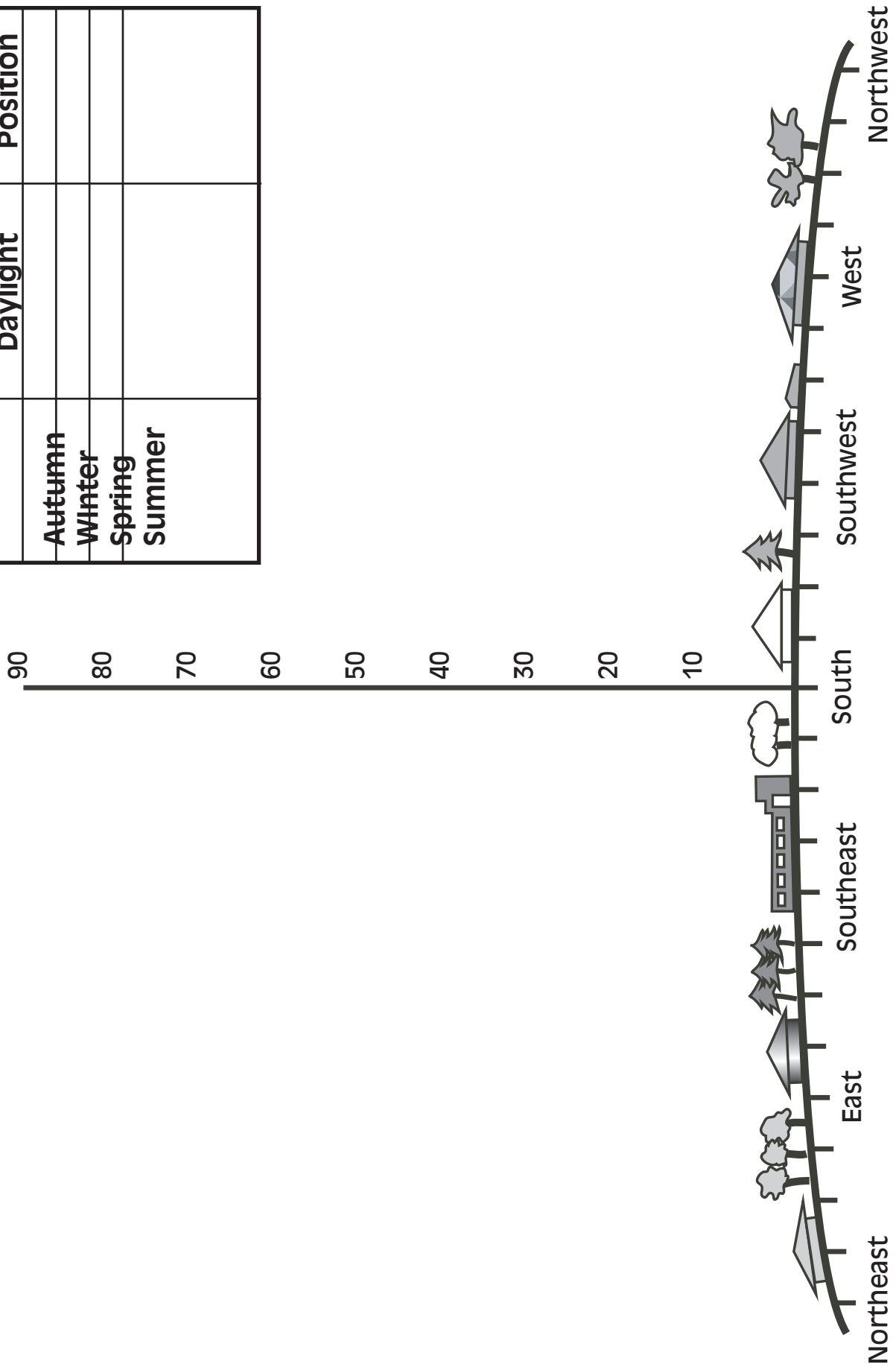

Follow-Up Activities

1. Prepare a grid to project onto your large Earth globe. The grid can be either a grid slide projected through a slide projector, or an overhead projector transparency. An easy way to make a grid is to photocopy a sheet of graph paper onto transparency and either cut a small piece of it to put in a slide mount or use the whole sheet on an overhead projector.

In class, first project the grid onto a flat surface (chalkboard, wall, etc.). Each box represents a unit of light and heat from the Sun and all the boxes are equal in size when they start out from the Sun. Have the students notice that all the boxes are the same size. If the Earth were flat, then all parts of the Earth would receive equal amounts of light and heat. Let's see what happens with a round Earth. Project the grid onto the Earth globe. **Are all the boxes the same size?** (No.) **Where are they the smallest?** (The parts facing most directly towards the Sun.) **Where are they the largest?** (Near the poles and parts not facing as directly towards the Sun – places where it's early morning or late afternoon.) **Remembering that each box contains the same amount of heat and light, who would be hotter, a person standing in a region with smaller boxes, or a person standing in a region with larger boxes?** (The region of smaller boxes would get hotter because more heat is concentrated there, while in regions where there are larger boxes, the heat is being "spread out.")

Put a piece of tape or a push pin at your city's location on the globe. Show the class how the grid boxes shining on the Earth change as the Earth is tilted towards the Sun (summer orientation) and then away from the Sun (winter orientation). **During which season does our city receive more concentrated sunlight?** (Summer.) That is a reason why it is hotter in the summer than in the winter.

2. With STARLAB this can be made into a student activity rather than a demonstration by using the same "Earth balls" that were used before. Prepare a grid transparency wrapped into a cylinder to replace the star cylinder. Alternatively, make an opaque cylinder out of manila cardstock and, using a large push pin, make an series of holes around the "equator" of the cylinder. Light from the main star bulb shining through these holes produce standard size "light circles" that will function as units of light as the grid boxes did in Follow-Up activity (1).
3. Prepare a class set of "Light Angle/Area Measuring Tools" by copying the bottom half of page 50 onto cardstock and cutting them out as shown (alternatively, provide your students with scissors and have them make their own). Cut along the dashed lines and fold along the dotted lines.

Start by having the students catch the grid boxes or light circles on flat pieces of paper. Have them note that the light boxes or circles are all the same size. Then go through the same sequence of questions used in Follow-Up activity (1), except that students can examine their own Earth globes in addition to a single large globe that the teacher handles.

Face the square window hole towards the white light "Sun" and position the paper so that a square of sunlight falls on the gridlines on the worksheet with the grid at 90° to the light rays. This is like the way the Sun hits the ground in the summer around noon (students recorded the real angle on the Reasons for Seasons worksheet). Count how many squares the sunlight covers. Now change the angle between the grid and the light rays (taking care to keep the square hole facing straight towards the Sun). This simulates how sunlight hits the ground in the wintertime. Again, count how many squares the sunlight covers. (More area is covered.)

Explain that while there is still the same amount of sunlight coming through the square, it is spread over a larger area of “ground,” so the ground receives less heat. That is another very important reason why it is colder in the winter. The Sun is lower in the sky, so its light hits the ground at a lower angle than in the summer. The lower the angle of sunlight, the more the light is spread out, giving less heat for a given area of ground.

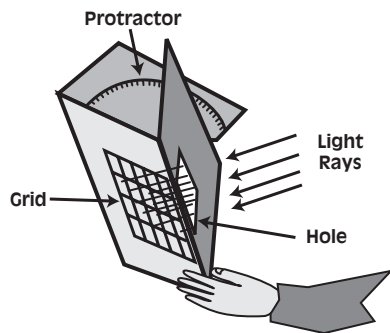

**Cut along dashed lines.
Fold along dotted lines.**

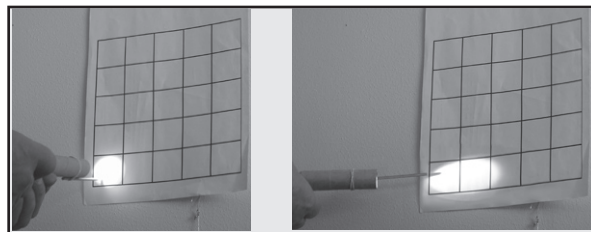

Alternative ways to illustrate how the angle of incidence of Sun’s rays on the ground affects intensity of light. Above: Using a flashlight with an extension tube to make a clean round beam, shining on a grid, and a rod to make the distance fixed.

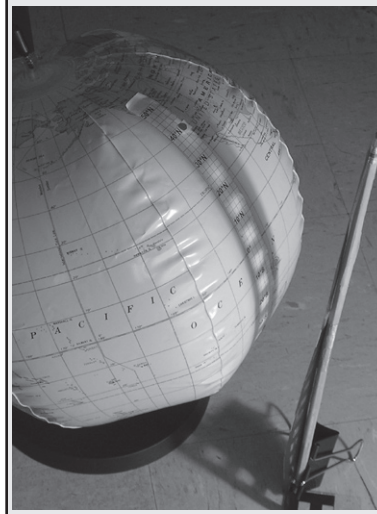

Left: Make a mask with a vertical column of 1-cm square holes and have a light shine through the holes onto a globe.

The Reasons for the Seasons Light Angle/Area Measuring Tool

Cut out
this
window

GROUND

-developed by Alan Gould
Lawrence Hall of Science
University of California

Activity 13: A False Color Density Map of the Milky Way

Grade Levels: 6-9

Organization: Small Group

Reasoning Level: Concrete to Formal

Activity Strategy: Direct Information and Synthesizing

Behavioral Objectives: By the end of this lesson, the students will be able to:

1. Describe the process by which a false color map is created.
2. Describe how the density of visible stars varies with respect to the plane of our galaxy.
3. Demonstrate how a flat two-dimensional map represents a three-dimensional object.

Preparation and Equipment

1. For this activity, you will need to project a north-south line and an east-west line to divide the sky into four quarters. The north-south line is called the “meridian line.” The projectors can be made or purchased from planetarium supply companies.
2. Set up the planetarium projector so the Milky Way arcs high across the sky.
3. To communicate the meaning of the pattern that the students discover when making their maps, you will also need a set of slides including two or three spiral galaxies (preferably from different angles) and a rich section of the Milky Way through a telescope, showing many stars.
4. Sight through a toilet paper tube and count stars in some dense regions of the sky, and some regions where stars are sparse, to determine the range of counts that the students will find. Prepare a four-color key that will represent the range of star counts in your planetarium. For a star projector with about 2,300 stars, we have found that the following key works well:

0 to 10 yellow	11 to 17 orange
18 to 24 blue	25 and up violet

Now that photographs are commonly used in elementary and junior high school level textbooks which provide views of our universe in wavelengths other than the visible spectrum, students need to learn how we can create images of something that the eye cannot see. This planetarium activity acquaints the students with the principles of false-color imaging as the students produce a density map of the Milky Way. In addition, the students learn about the structure of our galaxy.

Materials

- For each student you will need one empty toilet paper tube, one data sheet and a clipboard or other writing surface.
- You will need a set of four colors of crayons or magic markers for every two students (yellow, orange, blue and violet).
- You will also need one light pointer and one data sheet (p. 54) that you have cutout and assembled as a sky map. (Do not color the sky map, so that students may discover the pattern of stars on their own.)

Presentation

▶ To make a more open-ended activity for older students, don't specify the number of increments or choice of colors. Students can then discover that the display of data affects the "readability" of the results. Too many increments or alternating light and dark colors can hide the pattern.

You may wish to begin this activity by showing the students some false color maps, such as one of the United States using colors to indicate temperature (one appears daily in the *USA Today* newspaper). You could also show astronomical false color maps, such as radio galaxies, or a map of the Milky Way in infrared light.

Tell the students that they will make a false color map of the sky that will show which areas of sky have lots of stars and which areas of sky have just a few stars. The map we make will help us to look for patterns in how the stars are distributed across the sky.

To collect the data needed to make the map, they will need to sample equal areas of sky. Hand out empty toilet paper tubes. Use your pointer to indicate a particular star and ask all of the students to center their tubes on that star and count all of the stars they can see through their "toilet paper telescopes."

Ask the students to say the number of stars they see, one student at a time. Estimate a class average based on their counts.

Hand out the data sheets and explain that it is a map of the sky. Show the students an assembled map, showing how it can be cut, folded, and taped into a dome. Ask the students how many areas of sky are indicated. (28)

Tell them that they will use their "toilet paper telescopes" to determine the number of stars in each of the 28 areas of sky, and then color it with one of four colors to indicate how many stars they can see. Show them the color key for representing different numbers of stars with different colors.

Project the north-south and east-west lines onto the star dome, dividing the sky into four quadrants. Point out how each of the four quadrants in the sky corresponds to the four quadrants on their data sheets. Use the light pointer to illustrate how each quadrant can be further broken down into seven smaller segments. (Surprisingly, the students have had no difficulty visualizing these segments and estimating the approximate middle of each segment for taking star counts.)

Assign the students to work in teams of two or three. Tell them to work together in counting the number of stars in each segment, and to average their results. Each student should write the average number of stars in each segment of her own star map with a pencil. It takes approximately 20 minutes for a group of eighth graders to count all 28 segments. Help individual groups as needed.

When the groups have finished their observations, show them the color key. (You may also write the color key in the corner of their data sheets, so they do not forget.) Hand out crayons or markers so they can color their maps according to the numbers they have written in each of the segments. Teams of students can share one set of colors.

When the students are finished, ask them to describe their results. While some maps tend to be clearer than others, just about all of the students will find a concentration of stars along the Milky Way.

You may wish to end the activity by asking the students if they can explain why the stars seem to be concentrated along that region of the sky. Encourage some discussion.

Explain that the Milky Way was a great puzzle until telescopes were used to discover that certain faint patches of light in the sky were actually masses of billions of stars. (You may wish to point out a galaxy such as Andromeda in the planetarium sky, and show a slide of how it looks through a telescope).

It occurred to astronomers that perhaps the Sun was part of such a huge collection of stars. The work of many astronomers over the years have now established that the Sun is indeed part of a huge disk-shaped group of about 200 billion stars called the Milky Way. When we look along the plane of the disk, we see lots of stars. When we look up or down from the plane of the disk, we see very few stars.

If we make the planetarium sky very dark, we can see very faint “clouds” stretching across the sky. Telescopes show that these faint patches contain the billions of stars that are very far away, but still within the disk of our Milky Way. (You can illustrate this with other slides of Milky Way regions). In fact, all stars that we see in the sky are part of the Milky Way.

If we could see our Milky Way from out in space, it would look like a spiral-shaped disk. (You may show a slide of another spiral-shaped galaxy here.) Our Sun would be located about three quarters of the way out from the center.

Invite the students to take their data sheets home, and to cut them out along the heavy outlines. They should then fold it along all of the inner lines, and tape the outside, so it looks like the model you showed them. They would then have a false-color, three-dimensional map of the sky.

To reinforce the concept of false color maps, show some more maps such as radio or infrared maps of the Milky Way.

Full-Dome Map—Worksheet

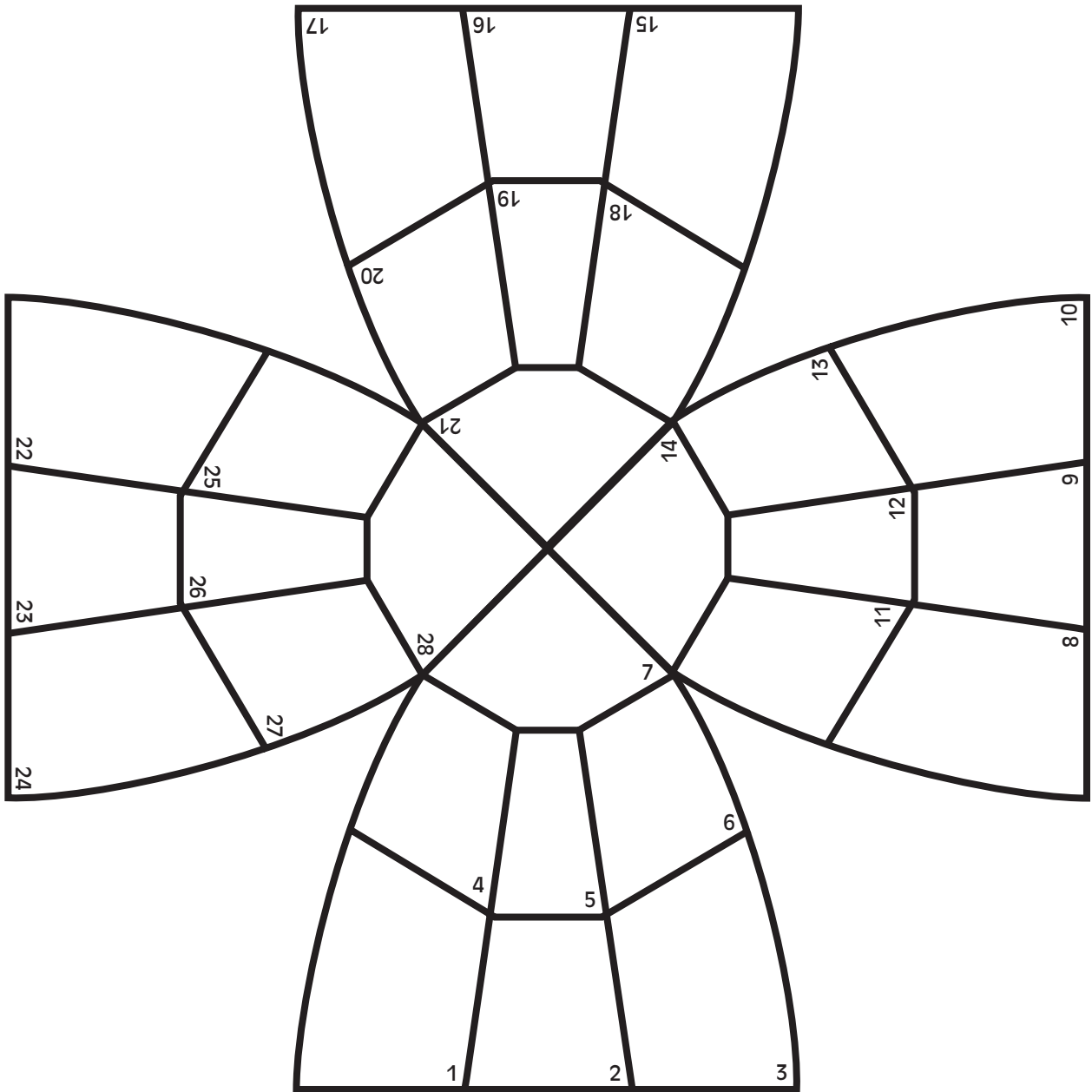

Activity 14: Stars Through the Ages

Grade Levels: 6-9

Organization: Small group

Reasoning Level: Formal

Activity Strategy: Synthesizing

Behavioral Objectives: By the end of the lesson, students should be able to:

1. Construct a star chart for two different time periods in the past: 3,000 B.C. and 10,000 B.C.
2. Locate the position of the north celestial pole for three different time periods: the present, 3,000 B.C. and 10,000 B.C.
3. Describe how the night sky was different in the past than it is today.
4. Explain the relationship between the changing orientation of the Earth's axis and the location of the north celestial pole.
5. Predict how the constellations and North Celestial Pole will change 5,000 years in the future.

Preparation

Set the planetarium projector for latitude 30° North (the mouth of the Euphrates river in Mesopotamia). Set precession for the present year, with 6 hours of right ascension on the meridian. You should be able to see Canis Major, Orion, Taurus, Cassiopeia, the Little Dipper, and the Big Dipper in the sky. To set the planetarium for the other dates (3000 B.C., 10,000 B.C., and 7000 A.D.), it will be necessary to follow the instructions that apply for your particular equipment. For planetarium projectors that allow the star Regulus to “slide” along the ecliptic, move precession until Regulus is set at the date of May 16 on the ecliptic for 3000 B.C.; the date of February 8 for 10,000 B.C., and Oct. 31 for 7000 A.D. For projectors that keep Regulus at the same place on the ecliptic use the position of the “Vernal Equinox” and set it at June 27 for 3000 B.C.; Oct. 3 for 10,000 B.C., and Jan. 10 for 7000 A.D.

Presentation

Point out that since we use constellation names today that had their origins in the ancient past, we often think that people long ago saw the sky exactly the same as we see it today. But did they? Tell the students that in today's lesson, they will have the chance to find out the answer for themselves, as they venture back in time to examine the sky as it would have been seen at the time and location of Ancient Mesopotamia, one of several ancient cultures where the study of astronomy began.

When we teach students about the reasons for seasons, we explain that the tilt of the Earth's axis stays the same as it goes around the Sun. However, that is not completely true. The Earth's axis slowly “wobbles” in a huge circle in approximately 26,000 years. While it maintains its “tilt,” it changes its “orientation” in space. This precession of the Earth's axis causes our pole star to change, and affects the constellations that we see in different seasons. Students learn about this advanced concept by observing differences in the planetarium sky when it is “set” for different epochs. This activity can only be done if your planetarium projector can be adjusted for precession.

Materials

For every pair of students

- one copy of the first data sheet (p. 57)
- two copies of the second data sheet (p. 58)
- a pencil
- clipboard or other writing surface

For a class demonstration

- a globe of the Earth mounted on an axis
- a top.

Activities for the School Planetarium



Begin by distributing the first data sheet, a simple star chart that shows three constellations above the southern horizon and three above the northern (Ursa Major, Ursa Minor, Cassiopeia, Orion, Canis Major and Taurus.) Give a brief explanation about how to locate constellations on the chart. (Example: if a star is seen halfway from the horizon to the zenith in the planetarium, then it should be positioned halfway from the edge to the center of the map.)

Invite the students to find these six constellations in the night sky. After the class has found these six constellations, turn on daily motion so that they can locate the position around which all stars move, and mark it with an “x” on their charts. Define this point as the *North Celestial Pole*.

Bringing the lights up, explain that today, the Earth’s north pole points in the direction of the North Star, or Polaris, so the North Celestial Pole is clearly marked by a moderately bright star. But to find out if that was always the case in the past, we have set the planetarium projector to show the sky in 3,000 B.C. (How many years ago was that?—5,000 years). We will then see how the sky appeared in the year 10,000 B.C. The location on the Earth will not be changed, but only the date.

To make a record of their observations, the students will have to construct star charts similar to the one that they used for the current sky. They will be working in groups of two, and will have to first carefully observe the sky to determine: 1) where the North Celestial Pole is located; 2) what constellations would be visible, and 3) where they would be seen in the sky. Distribute the data sheets to students and assign the students to their groups.

Set the planetarium for 3000 B.C. and dim the lights. Ask the students: Can Orion or any of the other constellations still be seen? Where is the North Celestial Pole now? (Turn on daily motion.) Once these questions have been answered, the students should identify which constellations they think should be drawn on their charts. Help them to determine approximately where they should be located on the paper. Give them time to work and then reset the planetarium for 10,000 B.C. Hand out the third data sheet and repeat the above procedure for this date.

Conclude the lesson by asking the students to compare their charts with some of the other groups that were working. How well were they able to recreate the appearance of the sky? Discuss the significance of some of the changes that they observed. How is it helpful to have a star near the North Celestial Pole? (Navigational aid.) What is the problem of using the rising or setting of a particular star as a method of keeping track of time? (Similar to the Egyptians’ use of Sirius—the star will not keep the same position over hundreds of years.)

Ask the students to explain in their own words, why they think the north celestial pole and constellations visible in a given season slowly change position over thousands of years. Allow some time for discussion. Then demonstrate how

most astronomers would explain it: Use the globe to show how the Earth spins on an axis that always stays oriented the same way in space, and is always tilted about 23.5° from a line drawn from the Earth to the Sun (or from the plane of the ecliptic.)

Today, the north pole of that axis points towards the North Star. But the axis slowly wobbles, completing a wobble in about 26,000 years. It stays the same angle with respect to the Sun, but very slowly changes its orientation in space. This is called *precession*. Precession can be seen with any spinning object. Use a top to demonstrate how the axis of the top wobbles (when it is not vertical). The circular motion of the top’s axis is another example of precession.

Summarize the main points, and ask the students to predict what changes they might anticipate in the sky for the year 7000 A.D. If time permits, allow them to check their predictions by setting the sky for 7000 A.D. for a final look at “Stars Through the Ages.”

Vocabulary

Constellation—a group of stars connected together to form a pattern or picture.

North Celestial Pole (NCP)—the point in space above the Earth's north pole. From Earth, all stars appear to revolve North Celestial Pole.

Evening Skies—Year: Present

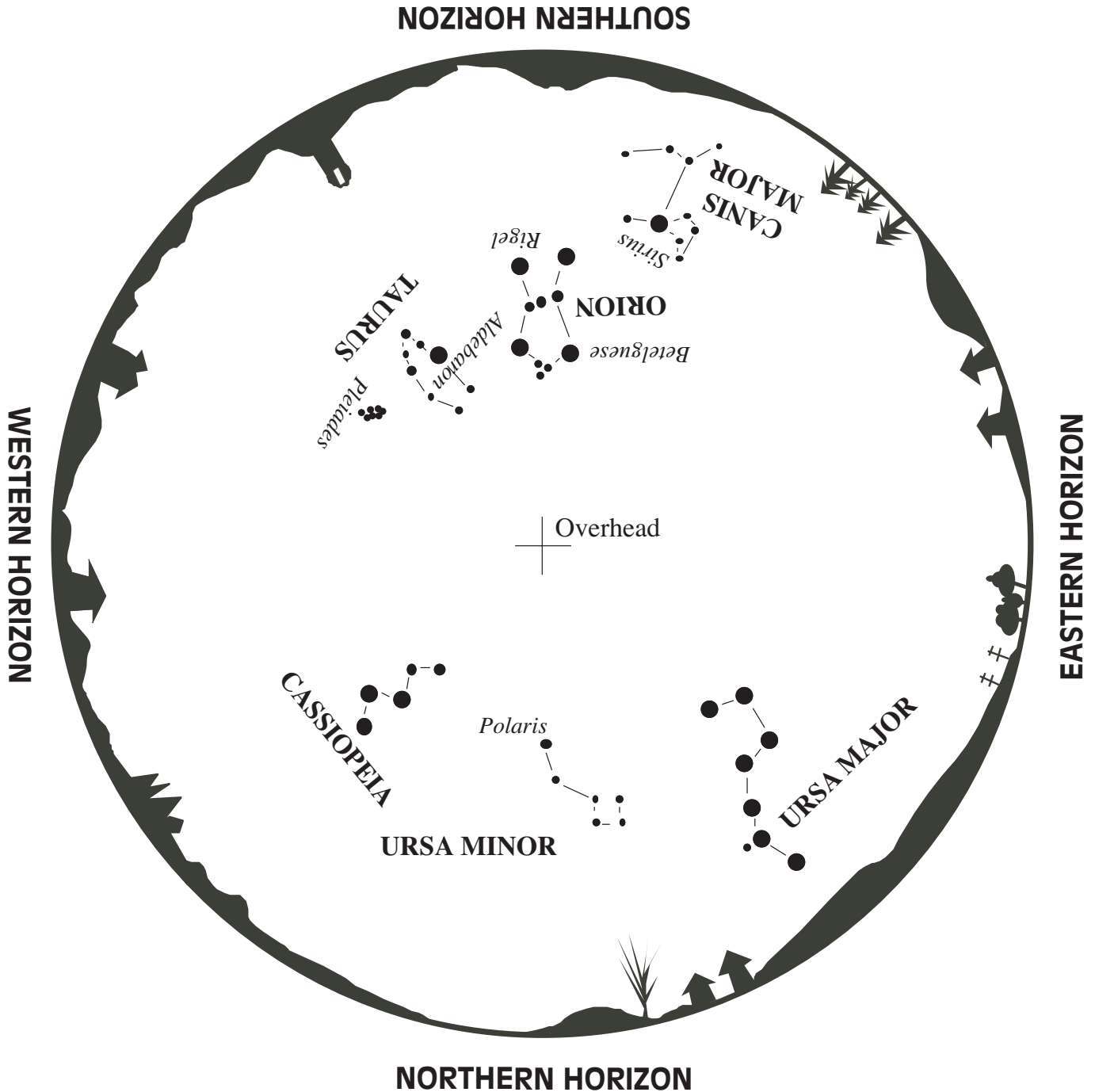

Vocabulary

Constellation—a group of stars connected together to form a pattern or picture.

Precession—a slow wobbling motion of the Earth, which causes the NCP to point to a different point in the sky as the years pass.

North Celestial Pole (NCP)—the point in space above the Earth's north pole.

Evening Skies—Year: _____ B.C.

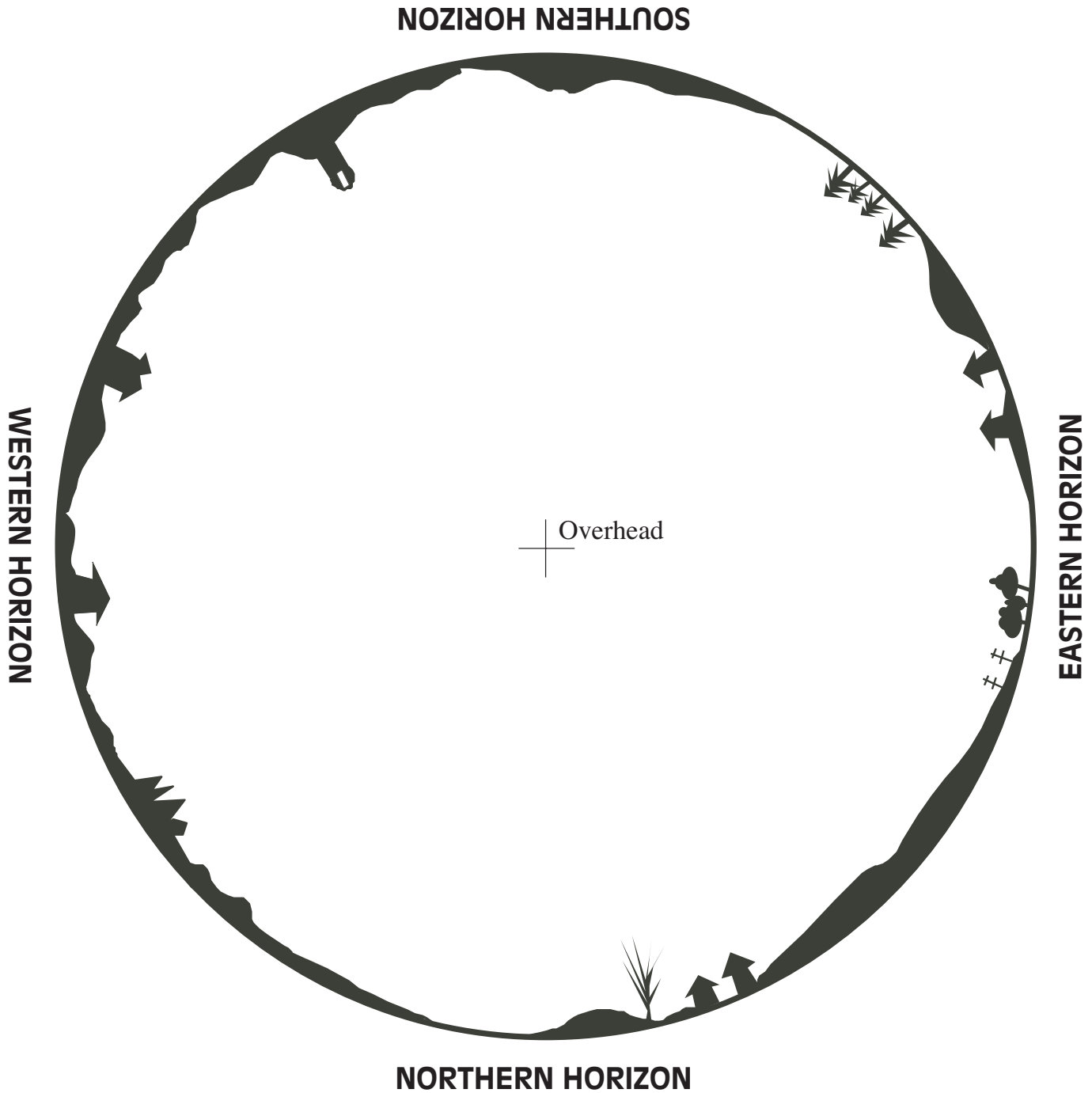

Activity 15: What's Your Sign?

Grade Levels: 6-9

Organization: Individual Task and Small group

Reasoning Level: Concrete to Formal

Activity Strategy: Direct Information and Synthesizing

Behavioral Objectives: By the end of the lesson, students should be able to:

1. Explain the astronomical meaning of their astrological birth sign, or Sun sign;
2. Explain why they cannot see their birth constellation on their birthday, and about how long they would have to wait to see it in the nighttime sky.

Older students will also be able to:

3. Define “sign of the zodiac” to be an invisible region of the sky that no longer corresponds to the “constellation of the zodiac” that has the same name.

Preparation

1. Tape or staple the black and blue sheets so that you have thirteen cards that are blue on one side and black on the other. On each black side make one of the constellations of the zodiac, using yellow stars or dots or paint. Label and number each constellation, as indicated on the master sheet.
2. Place a lamp or yellow ball in the center of the planetarium (above or below the projector) to represent the Sun.
3. (Optional, for introducing the effect of precession to older students) On each white sheet, write the name and symbol of one of the constellations of the zodiac, using a broad marker.

Presentation

Ask the students if they know their astrological birth “sign.” Most will probably know what it is. Then, ask if anyone knows what the astrological birth sign means in terms of the positions of the Sun, moon, and planets when they were born. (Accept their ideas and allow for discussion.) Tell the students that a person’s “sign” is a short way of saying their “Sun sign,” and they will learn what Sun sign means in this activity.

Arrange the students in a large circle around the planetarium. Have thirteen students hold the black and blue zodiac constellation signs so they are evenly spaced around the dome. (If doing this in a STARLAB Planetarium, have students sitting around the edge of the dome hold the cards.) The order of constellation signs should be Aries, Taurus, Gemini, Cancer, Leo, Virgo, Libra, Scorpius, Ophiuchus, Sagittarius, Capricorn, Aquarius, and Pisces. They should hold their cards so the black side with the stars faces towards the center of the room. Turn on the “Sun” light in the center of the room.

Most students are very interested in their astrological Sun sign, though very few understand its astronomical significance. You can exploit your students’ interests in astrology to help them learn about how and why the constellations change with the seasons, and how the seasonal appearance of the constellations has slowly changed over the past two thousand years because of precession of the Earth’s axis. The activity uses the technique of having the students model the Earth, Sun, and constellations with their bodies. Suggestions are also given for helping the students to separate astronomy from the pseudo-science of astrology.

Materials

- 13 sheets of white paper
- 13 sheets of black construction paper
- 13 sheets of light blue construction paper
- clear tape or a stapler
- a broad marking pen
- and material for making stars (such as yellow sticky dots, gold stars, paint, or whiteout).

To check student understanding, you may also want to make one copy of the data sheet for each student, and provide pencils and clipboards or other writing surfaces.

Activities for the School Planetarium

Explain that in this model of the sky, the Sun is in the center, and the zodiac constellations are arranged in a big circle, some unknown distance away. As we know today, the Earth goes around the Sun.

Ask for a volunteer to represent the Earth. Ask her to stand between the Sun and the circle of constellations and to walk once around the “Sun.” Ask the students, “How much time goes by when the Earth goes around the Sun once?” (One year.)

Now align the Earth person so that from her point of view, the Sun is blocking out the constellation of Aries. Explain that this is the Earth’s approximate position during the period April 21 to May 20. Ask the “Earth,” “What constellation is behind the Sun?” (Aries.) Explain that anyone born on the Earth at this time is born under the “Sun sign” of Aries.

Ask the person to slowly continue in the Earth’s orbit until the next constellation is obscured by the Sun, and to announce when that occurs by saying “Now the Sun is entering the constellation of...,” and so on for two or three constellations.

Point out that the Sun continues to block any given constellation for about one month, since there are twelve zodiac constellations. Anyone born during that month is born under that Sun sign. Ask the students, “Can you see your Sun sign constellation on your birthday?” (No, the Sun is in the way!)

To illustrate and expand on this idea, ask the student who is playing Earth, to face towards the Sun, and name all of the constellations that she sees. Ask the Earth person, “What time of day is it for people who live on the front part of your face?” (Daytime, or noon.) Can these people really see these constellations? (No.) So, each person holding a constellation sign that was named should turn it so that the blue part faces towards the Earth.

Ask the Earth person to turn slowly until the “Sun sets,” and the stars come out. As she turns, she can see more and more constellations (each of which should now have their black sides with stars and names facing the Earth.) Tell the Earth person to keep turning until the Sun is behind her. Ask, “What time of day is it now for people who live on the front of your face?” (Nighttime, or midnight.) Ask her to name the constellations that she can see in the night sky. Have that person walk around the Sun, and stand in the position of the Earth six months later. Again, have daytime constellations turn their blue sides towards the Earth, and have the Earth turn to observe constellations in the nighttime sky.

To see if the students understand the model, ask them if they can see their birth or Sun constellation on their birthdays? (No.) How long would they have to wait to see their birth constellation overhead at midnight? (About six months.) Hand out the data sheet and allow time for the students to answer the questions. Allow some time for discussion of the answers.

Using the planetarium sky, point out a zodiac constellation and ask the students to point out where they would expect another one to be. Reinforce the idea that the zodiac constellations were not chosen because they were bright or easily found, but because the Sun appeared to be in front of them. The zodiac forms a line or circle around the sky.

To reinforce the students’ understanding of astrological signs, ask the students if they can guess what their astrological “moon sign” is. (It is the constellation of the zodiac where the moon was at their birth. Similarly, the “rising sign” or “ascendant” is the sign of the zodiac that was rising on the eastern horizon at the moment when they were born.)

Astrologers divide the sky into only 12 astrological signs (constellations), omitting Ophiuchus. You will never find an astrologer designate anyone's birth sign as Ophiuchus! Astrologers further assume that the Sun is in each sign for one month. *Astronomers*, in contrast, divide the sky into constellations with precise boundaries. The amount of time that the Sun is in each constellation of the zodiac is different, being determined by the exact constellation boundaries. The exact times that the Sun is in each constellation are given on pages 63–64 in the column "Astronomers' Dates." Notice that astrologers' dates are about one month off!

Sum up by telling the students that they have just created a model which illustrates the meaning of the "astrological birth sign," or "Sun sign." Whether or not they believe in the *pseudo-science of astrology*—which claims that people born under the same astrological sign have certain common characteristics—is up to them. The *science of astronomy* makes no such claim.

The students may be interested to know that several hundred years ago, when most people believed in astrology, many famous astronomers, such as Claudius Ptolemy, Johannes Kepler, and Tycho Brahe, made their living by making astrological predictions. (Your students may want to look up these names in an encyclopedia to find out their contributions to astronomy.) Some modern historians claim that the most important motive for studying astronomy through the ages has been the desire to make more accurate astrological predictions. So, if it were not for the practice of astrology in the past, there might be no science of astronomy today!

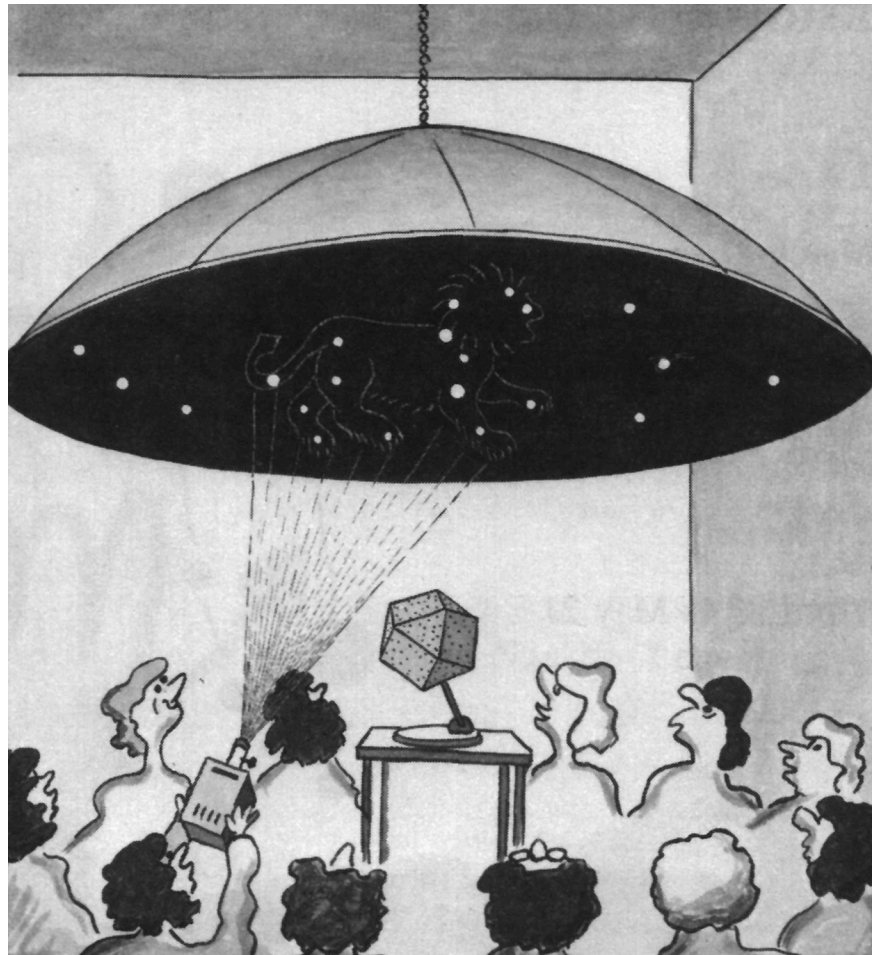

The articles below have excellent information on the relationships & distinctions between astronomy and astrology:

Mechler, Gary, Cyndi McDaniel, & Steven Mulloy, "Response to the National Inquirer Astrology Study," submitted to *The Skeptical Inquirer*, May 6, 1980. Study done at Northern Kentucky University.

Shapiro, Lee T., "The Real Constellations of the Zodiac," *The Planetarian* (the International Planetarium Society journal), March, 1977, pages 17-18.

Fraknoi, Andrew, "Your Astrology Defense Kit," *Sky and Telescope*, August, 1989, p. 146.







Good articles and classroom activities on debunking astrology may be found in the *Universe in the Classroom Newsletter #11*, Fall 1988. It is available from Astronomical Society of the Pacific, 390 Ashton Ave., San Francisco, CA 94112, (415) 337-1100.

Optional

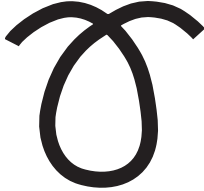

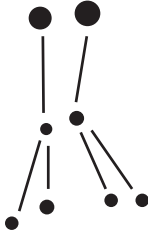
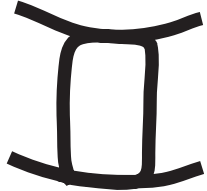

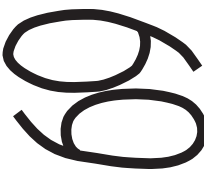
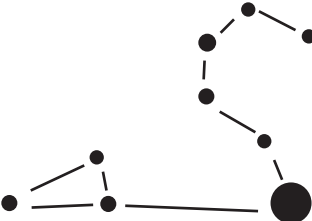
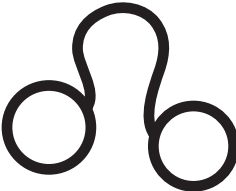
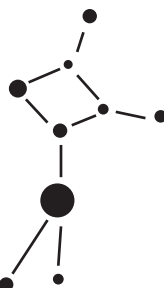



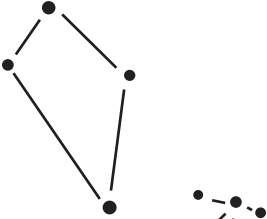

For older students, go on to explain the difference between “sign” and “constellation” as follows: More than 4,000 years ago, when astrology was invented, the Sun always lined up with the same constellations on the same dates. However, as hundreds of years went by, astronomers began to notice that the dates when the Sun was expected to line up with one constellation slowly changed, so that now, over 4,000 years later, the zodiac constellations have “slipped” one entire constellation. This is now known to be caused by the slow “wobble” of the Earth’s axis called **precession** (described in more detail in Activity 14: Stars Through the Ages.)

Astrologers, however still judge a person’s Sun sign according to the ancient dates. This means that a person born between April 21 and May 21 is still said to be born “under the Sun sign of Taurus,” but on that person’s birthday, the Sun was actually lined up with the constellation Aries. (The moon sign, rising sign, and other astrological signs are also off by about one constellation.) Thus, the term **sign of the zodiac** has come to mean an invisible area of sky that no longer corresponds to the **constellation of the zodiac** that has the same name. In about 26,000 years, when the Earth’s axis completes one slow wobble, the signs and constellations of the zodiac will again line up.

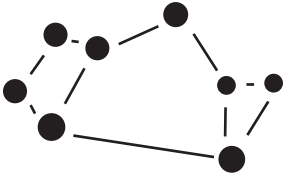
Illustrate this idea by handing out white sheets with the symbols and names of the zodiacal signs. Arrange these in a circle, so that the signs are held by students one position to the left of the constellations of the same name, e.g. the sign of Aries will be in front of the constellation of Pisces. Have another volunteer name both the sign and constellation that the Sun lines up with in different months. How can we model the way things will be in 4,000 A.D.? (Move the signs one more position to the left.)

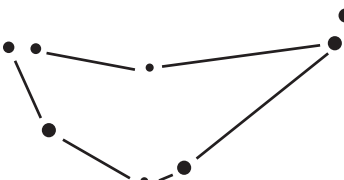
Astrologers' Dates	Constellation	Symbol	Astronomers' Dates
1 Aries March 21 to April 20			Apr 19 to May 13 (25 days)
2 Taurus April 21 to May 21			May 14 to Jun 19 (37 days)
3 Gemini May 22 to June 21			Jun 20 to Jul 20 (31 days)
4 Cancer June 22 to July 22			Jul 21 to Aug 9 (20 days)
5 Leo July 23 to Aug 23			Aug 10 to Sep 15 (37 days)
6 Virgo Aug 24 to Sep 23			Sep 16 to Oct 30 (45 days)

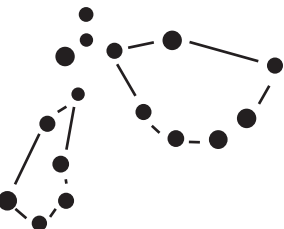
Master for Making Zodiac Cards

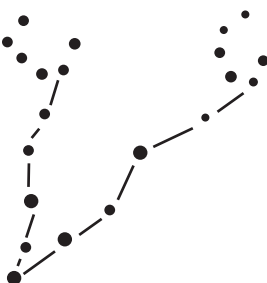
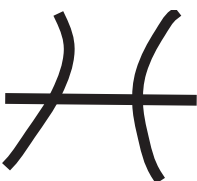
Astrologers' Dates	Constellation	Symbol	Astronomers' Dates
7 Libra Sep 24 to Oct 23			Oct 31 - Nov 22 (23 days)
8 Scorpius Oct 24 to Nov 22			Nov 23 - Nov 29 (7 days)
Ophiuchus (Not recognized as a sign of the zodiac by astrologers)		Has no symbol	Nov 30 - Dec 17 (18 days)
9 Sagittarius Nov 23 to Dec 21			Dec 18 - Jan 18 (32 days)
10 Capricorn Dec 22 to Jan 20			Jan 19 - Feb 15 (28 days)
11 Aquarius Jan 21 to Feb 19			Feb 16 - Mar 11 (24 days)
12 Pisces Feb 20 to Mar 20			Mar 12 - Apr 18 (38 days)

The Zodiac in Day and Night

1. In the picture below, which Zodiac Constellation would be behind the Sun as seen from the position of Earth in the drawing?

2. Which Zodiac Constellation would be seen overhead at midnight for the position of the Earth in the drawing?

3. Draw the Earth in the proper place for your birthday and list the following information:

For my birthday (list date)

a. The Constellation behind the Sun is

b. The Constellation overhead at midnight is

4. Which constellation in the astronomers' zodiac is missing in the picture below?

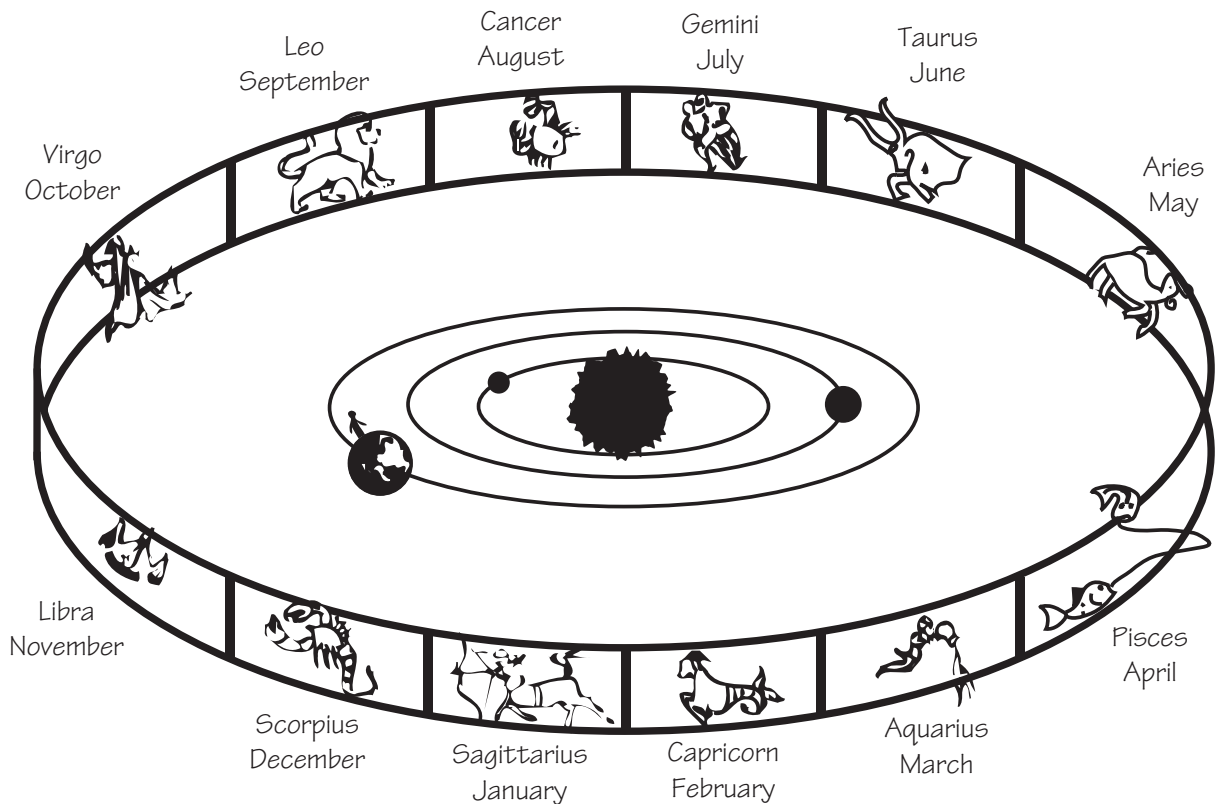

Treasure Island, by Robert Louis Stevenson, is a classic book often included in the secondary English curriculum. In this lesson, students explore some of the navigational tasks that would have been encountered by the characters in the fictional trip to Treasure Island.

Materials

For making Height-O-Meters, each student needs:

- 1 Height-O-Meter outline sheet
- 1 Height-O-Meter instruction sheet
- 1 push pin
- 1 small piece of wood or pencil eraser
- 1 sheet of cardboard or posterboard (8½" x 11")
- Ruler, scissors, and glue stick to share with other students

For the Treasure Island Activity, you will need:

- 1 completed Height-O-Meter for each student
- 1 data sheet for each student
- 1 map for each student
- 1 Earth globe
- 1 flashlight pointer
- recording of "Fifteen Men on a Dead Man's Chest" or other appropriate "pirate" music, and a recording of sea sounds, such as waves, seagulls, etc.
- "Treasure" — some sort of trinket for the winning crew.

Optional

- images which show navigational tools used in the 19th century)

Activity 16: The Trip To Treasure Island

Grade Level: 7-9

Organization: Socratic, Small Group

Reasoning Level: Concrete to Formal

Activity Strategy: Direct Information; Synthesizing

Behavioral Objectives: By the end of the lesson, students should be able to:

1. Determine their approximate latitude on Earth by measuring the altitude of the north star using a "Height-O-Meter," used as a mariner's astrolabe.
2. Determine their approximate longitude given the time in Greenwich and their local time.
3. Plot their estimated position on Earth by means of a map using latitude and longitude.

Preparation

Height-O-Meters should be constructed in the classroom before students come to the planetarium. Copy the Height-O-Meter outline and instruction sheet and provide these to teachers who will be bringing students to the planetarium. It takes one or two class periods for the students to make and calibrate their Height-O-Meters.

Set the planetarium for 50° N. latitude, and set the Sun for the date of August 20 (for STARLAB users simply remove the August rivet). For STARLAB users, before the students arrive, align the planetarium projector for the different latitudes that will be used in the lesson, and place a mark on the alignment edge of the projector so that you will be able to easily set the machine during the lesson. Also make note of which Sun rivets will need to be removed during the lesson.

Presentation

As students enter to the tunes of "pirate music," welcome them to the planetarium, and wish them safe voyage on their "Trip To Treasure Island." Divide the students into teams of three students. Tell them to listen very carefully to find out how to navigate because the crew that does the best job, with the fewest errors will be rewarded with the treasure.

Explain that finding one's way across the ocean took a lot of skill and knowledge to use the various tools and charts that were available. This was not a skill that all sailors possessed. It was mainly the Captain and his officers that knew how to navigate. This knowledge was a power that the Captain could hold over a crew. A crew would think twice about disobeying the Captain, because usually the Captain was the only one who could get them home again. In the story of "Treasure Island" this idea is clearly expressed in the passage where Tom is hiding in the apple barrel and listening to the pirate's plans.

Long John Silver's preferred plan was to mutiny only after the treasure was recovered and Captain Smollet had charted their course for the way home. Long John knew however that the pirates would not be patient enough for this plan.

Tell the students that one of the first skills that all sailors had to learn was how to find the North Star. Many students know how to find the Big Dipper, so ask for volunteers to point this constellation out first. Ask for other volunteers to identify the Pointer Stars and the North Star.

With this background, discuss how we determine our position on Earth. Review the system of coordinates of latitude and longitude with the students. Remind them that *latitude* is measured in degrees north or south of the equator and that *longitude* is measured in degrees east or west of the prime meridian. By knowing both coordinates, we can plot our position on the Earth. Point out that their task during the trip, will be to find both the latitude and the longitude of each mystery point along their journey and to mark it on their map.

Longitude was by far the more difficult system to invent, but for students it is sometimes the easier one to understand. To learn how the system works, explain to the class that they are going to compare longitude to time. First, ask the students how many degrees there are all the way around the Earth? (Answer: Since the Earth is round there are 360° .) Next ask the students how long it takes for the Earth to turn completely around, one time? (Answer: It takes the Earth twenty-four hours to turn around.) Finally, ask the class if they can figure out how many degrees the Earth turns each hour. (Answer: If we divide 24 hours into 360° , we find out that the Earth turns 15° per hour.) Explain that another way to look at this, is that there is fifteen degrees difference in longitude for each hour difference in time.

Ask the class to try a sample problem. If there is a three hour difference between two cities (such as San Francisco and New York), how many degrees are they apart? (Answer: 45° .) Now since longitude is measured from the Prime Meridian which runs through Greenwich, England, as long as we know the time in Greenwich, and we know our own local time (perhaps from using a sundial), we can figure out our longitude! Ask them to calculate their longitude if it is midnight in Greenwich and 7 PM in our location. (Answer: $5 \text{ hours} \times 15^\circ = 75^\circ$.) In order to make this system work, the Captain would have to keep a clock aboard the ship that would show the time in Greenwich. This was a very important tool for navigation. Explain that for our voyage, you will tell them the time difference, and they will have to carefully multiply by fifteen degrees to determine the longitude.

Next, explain how to determine latitude. Using an Earth globe, illustrate how the axis of the Earth points towards the North Star. Then, make a sketch on the chalkboard to show why a person standing at the North Pole would see the North Star directly overhead. The angle between the horizon and the North Star is 90° . What is the latitude

of the North Pole? (90° , the same as the angular height of the North Star in the sky). Use the same drawing to show that a person standing at the Equator would see the North Star on the horizon. That is, at 0° above the horizon. What is the latitude of the equator? (0° , again the same angular height of the North Star.) The same is true for all latitudes in between. Just measure the angular height of the North Star above the horizon, and that angular height is the same as your latitude.

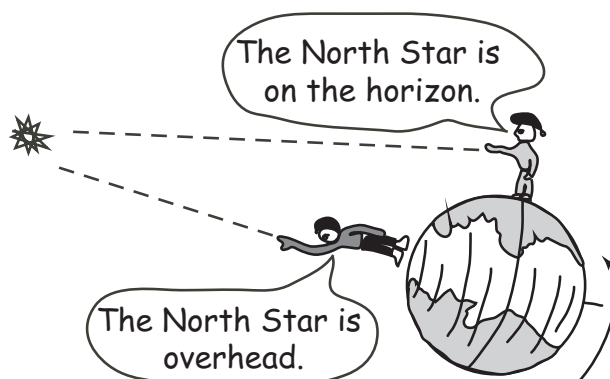

Unknown Positions

Following is a list of three “unknown positions” in the Atlantic. For these problems, all of the positions are **west longitude**. For more advanced classes you may explain that if the number is above 180°, then their ship has passed the International Date Line and the coordinate would be changed to **east longitude** [by subtracting from 360°].

Position 1

Date: March 24

Greenwich Time: 12 midnight

Your Time: 10 PM

Planetarium latitude: 45° N.

Coordinates for this location:
30° W longitude, 45° N latitude

Position 2

Date: April 23

Greenwich Time: 12 midnight

Your Time: 9 PM

Planetarium latitude: 35° N.

Coordinates for this location:
45° W longitude, 35° N latitude

Position 3

Date: May 24

Greenwich Time: 12 midnight

Your Time: 7:30 PM

Planetarium latitude: 25° N.

Coordinates for this location:
67.5° W longitude, 25° N latitude

Ask the students to take out their Height-O-Meters. Tell them that this instrument is a simplified version of an instrument that navigators use to measure the height of stars in the sky, called an *astrolabe*. Ask the students to try out their astrolabes by sighting on a star that you designate at the zenith in the planetarium. They do so by holding their Height-O-Meter in one hand, while sighting along the tops at the star. Then, with the other hand they pinch the swinging disk to the handle, and read the angle.

Go around the room and ask for their measurements. If you have more than one row of seating in your planetarium, the students will get different answers, depending on where they are sitting. Use this opportunity to help students whose answers are very different from their neighbors. However, tell the students that in the real sky, they would all get the same answer since the real stars are very far away. Explain that in the planetarium, to measure the height of the North Star most accurately, they must stand along the East-West line, as close to the planetarium projector as possible. Point out these positions to the students, and explain that one student in each group will take a turn measuring the height of the North Star as they all sail on board their pirate ship from one place to another.

Remind the students that at the end of the voyage you will compare all of the crew member’s position measurements with the actual numbers and the crew that is off the least will be the winner!

The Voyage to Treasure Island begins. Play a recording of sea sounds and reset the planetarium for the first unknown point on the journey. (See list of sites below). When you are ready, invite two students from each crew to take turns measuring the height of the pole star, standing on the east and west sides of the planetarium projector. While this is happening, the other students in each crew, should determine the longitude (by multiplying). All students should complete their logs with the necessary information. While the students are doing this, reset the planetarium projector for the next location. Repeat the same procedure, except with different students from each crew making the measurements. Finally, set the planetarium for the third and final position.

After the students are finished, hand out the map of the Atlantic Ocean. Have the students plot the three unknown positions on their maps. Have each crew report their coordinates for latitude and longitude for each of the unknown positions.

Read the actual coordinates for each position, and have the students copy these onto their data sheets. Have them find the difference between their estimates and the actual coordinates, and then total the number of degrees error at the bottom of the page. If there is time, have students in different teams trade papers to be certain that they calculated the errors accurately. Ask the crews to discuss where they thought their errors occurred. Was it in the calculations or in using the astrolabes? Finally, thank everyone for their participation and congratulate the winning crew for finding the treasure, and give them their reward.

Making and Using Height-O-Meters*

To Make Your Height-O-Meter

1. Place the Height-O-Meter outline sheet *face down*, and smear glue on the back of the master, covering the heavy lines.
2. Stick the Height-O-Meter outline sheet to the cardboard sheet, pressing and smoothing it. Then cut out the two parts of the Height-O-Meter.
3. Lay the **POINTER** piece *printed side up*. Using a ruler, fold along fold line 1, then fold it back the other way and tape it down along the backside (printing should be showing, not hidden). Fold the two sights (fold lines 2 and 3) so they are pointing straight up. Fold the handle along fold line 4 and tape it lengthwise.

4. Assemble the Height-O-Meter by inserting a push pin through the tack marks of the handle piece, the half-disk, and into a small piece of wood or pencil eraser. Work the push pin around to enlarge the holes so the disk swings freely.

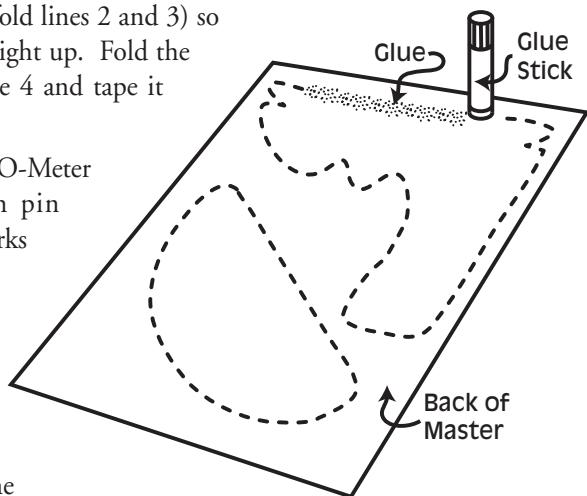

* Adapted from *Height-O-Meters*, a teacher's guide in the *Great Explorations in Math and Science* series. For more information, write to: GEMS, Lawrence Hall of Science, University of California, Berkeley, CA 94720, or call (415) 642-7771.

You will need

- 1 Height-O-Meter outline sheet
- 1 Height-O-Meter instruction sheet
- 1 push pin
- 1 small piece of wood or pencil eraser
- 1 sheet of cardboard or posterboard (8½" x 11")
- a ruler, scissors, and glue stick to share with other students

To Use Your Height-O-Meter

Hold the Height-O-Meter in one hand, and sight along the top edges of *both sights* so they line up with an object. Pinch the half-disk against the handle piece and read the object's height in degrees.

To Calibrate Your Height-O-Meter

Place a piece of masking tape on the wall at eye level. Step back to the middle of the room, sight on the center of the tape, and see if the Height-O-Meter reads close to zero. If it is more than one or two degrees off, place a paper clip on the half-disk and adjust it so the Height-O-Meter reads zero when pointed horizontally.

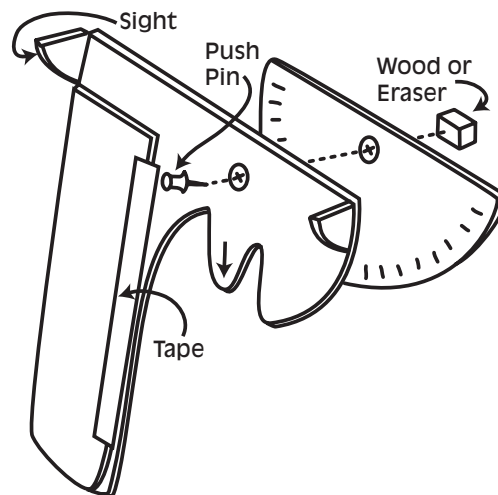

Note: There is a free astrolabe workshop on the web at <http://www.ifa.hawaii.edu/tops/astlabe.html>. It allows you to construct one, based on your location.

Sight

Fold 1

Fold 1

Fold 1

Fold 1

Sight

Sight

Name: _____

Sight

HEIGHT — ⊕ — METER

tack
mark

Eye Level _____ m

POINTER



Fold over and tape so this writing is hidden.

Fold 3

Fold 2

Fold 4

Fold 4

Fold 4

Fold

Developed by Alan Gould, Lawrence Hall of Science - © 1988 by the Regents of the University of California

HEIGHT — ⊕ — METER

tack
mark

SCALE (in degrees)

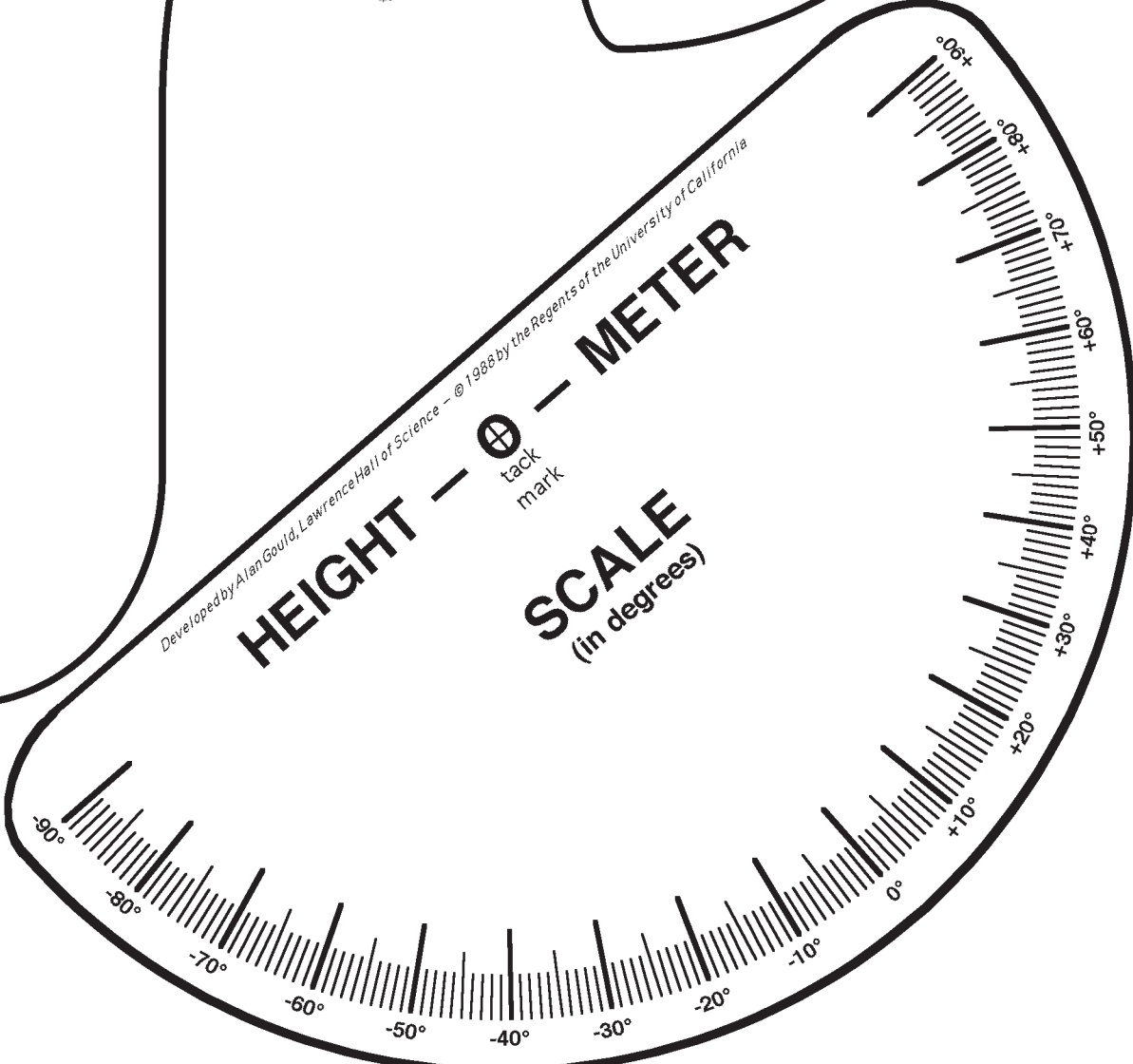

The Trip To Treasure Island Data sheet

Position 1

The time in Greenwich is _____

Your time is _____

The time difference is _____ hours

Your longitude is _____ x 15° = _____ ° West Longitude

The height of the North Star at this location is _____ °

My estimates for Postion 1

Actual Coordinates

Difference

Longitude _____ ° West _____ ° West _____ °

Latitude _____ ° North _____ ° North _____ °

Position 2

The time in Greenwich is _____

Your time is _____

The time difference is _____ hours

Your longitude is _____ x 15° = _____ ° West Longitude

The height of the North Star at this location is _____ °

My estimates for Postion 2

Actual Coordinates

Difference

Longitude _____ ° West _____ ° West _____ °

Latitude _____ ° North _____ ° North _____ °

Position 3

The time in Greenwich is _____

Your time is _____

The time difference is _____ hours

Your longitude is _____ x 15° = _____ ° West Longitude

The height of the North Star at this location is _____ °

My estimates for Postion 3

Actual Coordinates

Difference

Longitude _____ ° West _____ ° West _____ °

Latitude _____ ° North _____ ° North _____ °

Total error for all three sets of coordinates _____ °

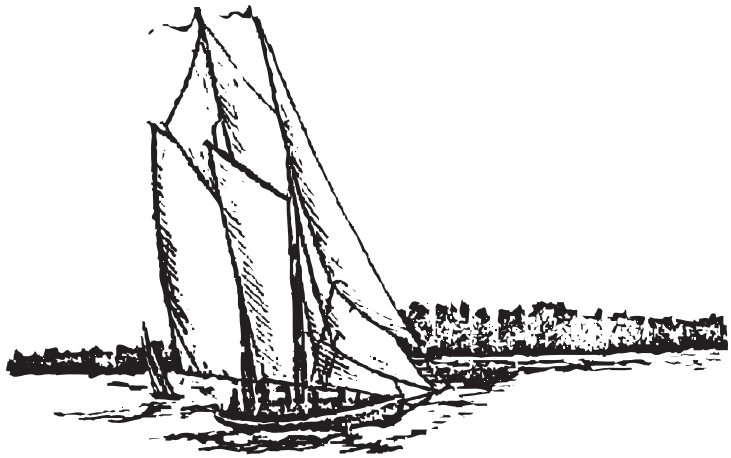
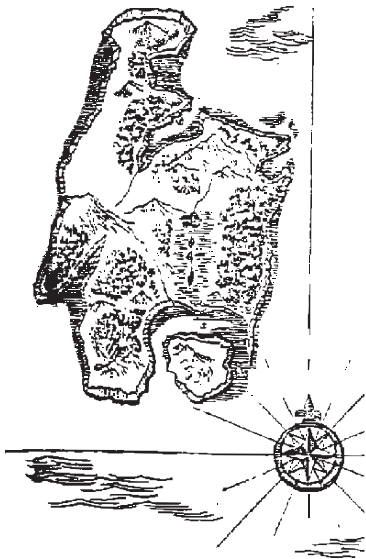
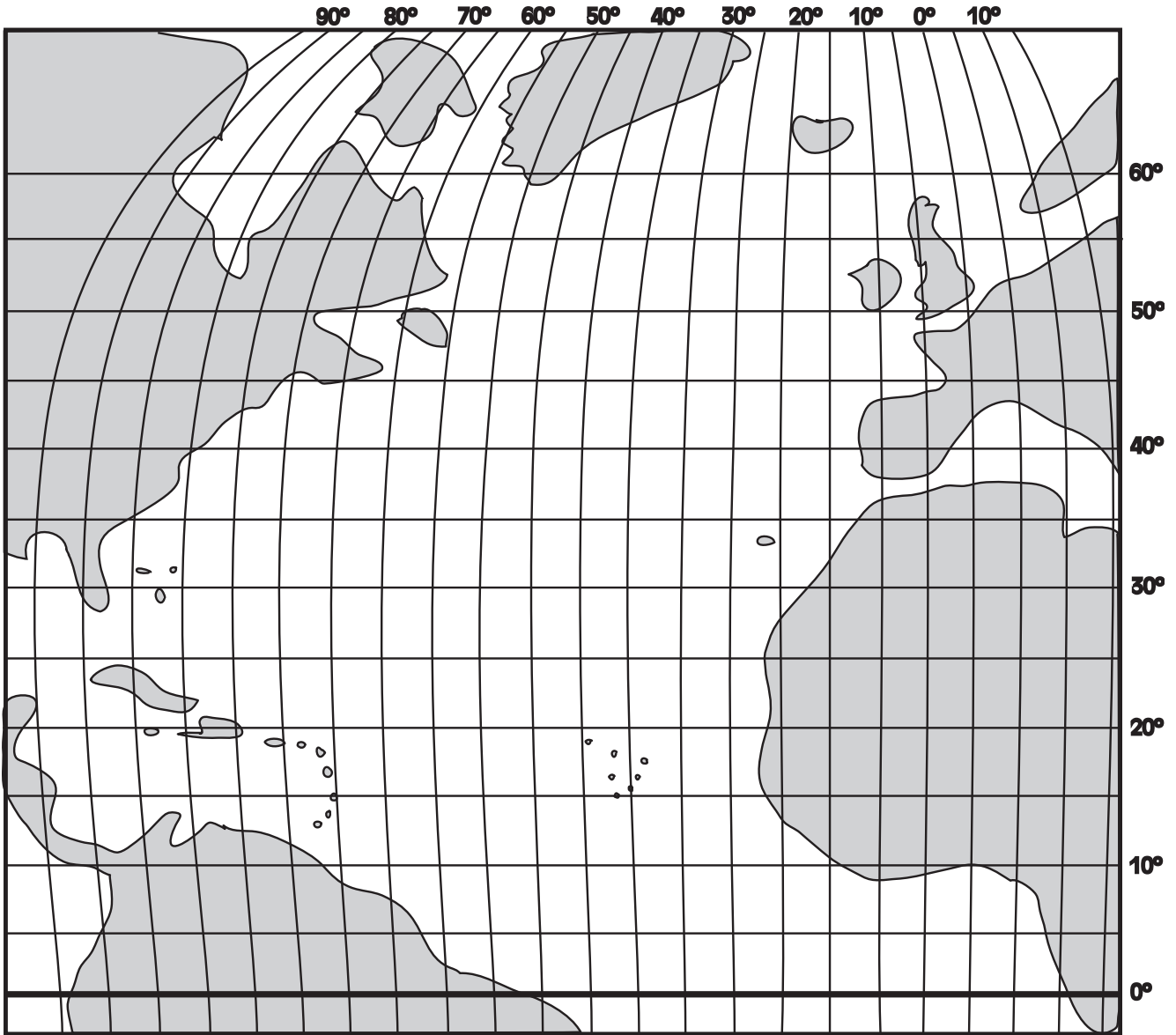

Ahoy, The Schooner!

Optional

Older students may be able to determine their latitude by the Sun. To explain how, draw on the chalkboard the diagram shown below (right).

Point out that the angle from the zenith to the Sun at noon is equal to the latitude angle. After the class has marveled at how simple this seems, ask them if the Sun's rays at noon are always striking the equator at 90° . (Only at the autumnal and vernal equinoxes.) On most days of the year, a correction factor must be added (or subtracted) from the observed angle. The captain would keep a "correction table" locked away in his cabin. Students may use the "correction chart," known as an analemma shown on this page.

In practice, your students will measure the angle from the ground to the Sun. They must subtract this number from 90° to compute the angle from the zenith to the Sun. They must then find the correction angle by finding the current date on the analemma and noting the corresponding "declination angle." If the correction angle is positive (North declination), then it must be added to the zenith-Sun angle to compute latitude; if the correction angle is negative (South declination), then it must be subtracted from the Sun-zenith angle to compute latitude. (For southern hemisphere, reverse the sign of the correction angle.)

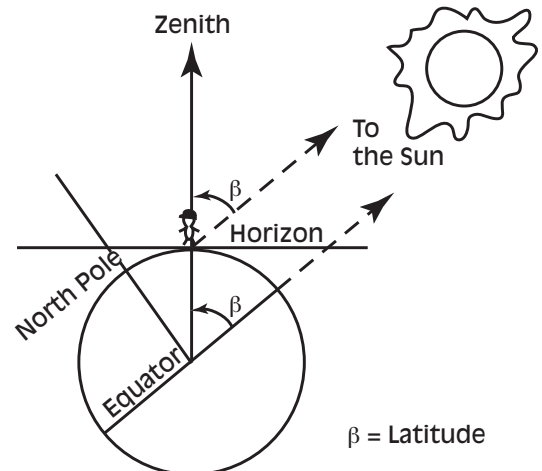
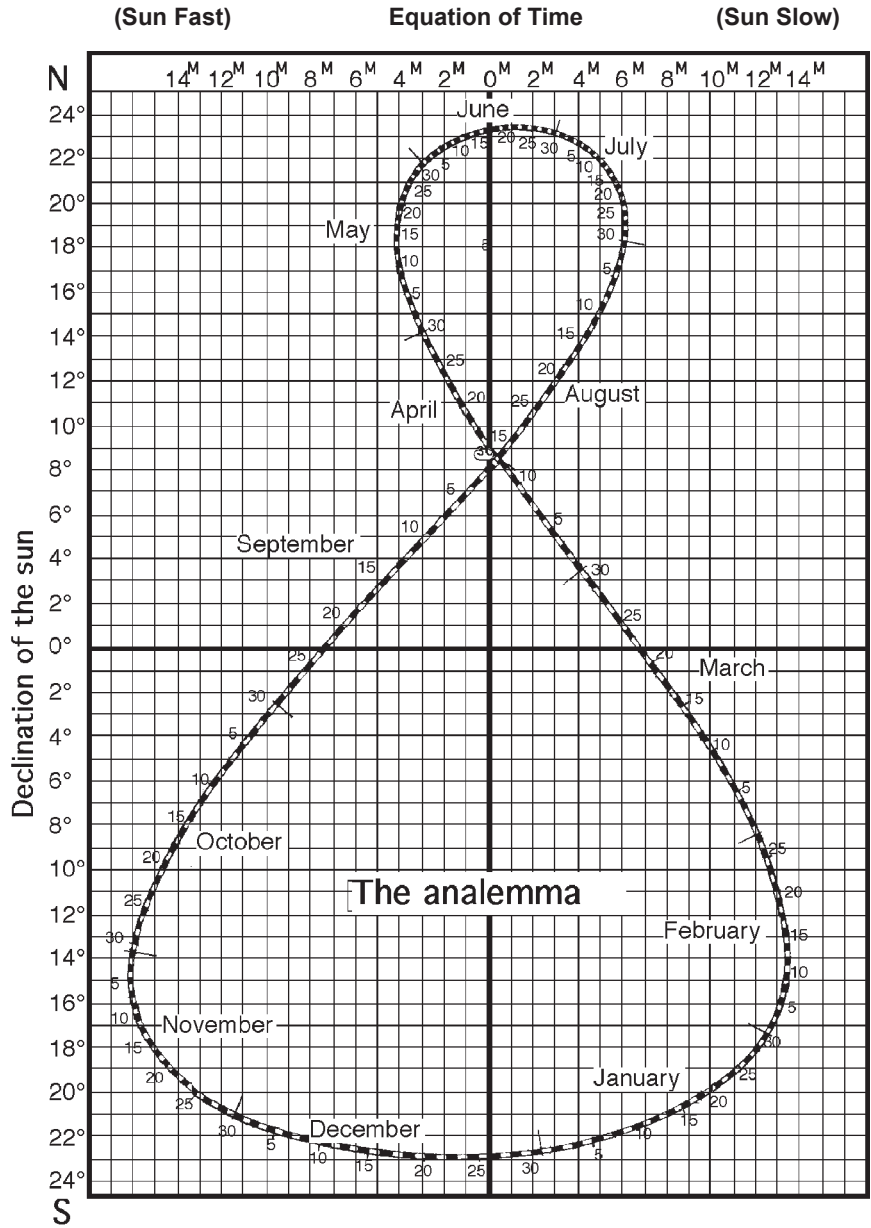

Activities for the School Planetarium

Planetarium Activities for Student Success