

Red Planet Mars

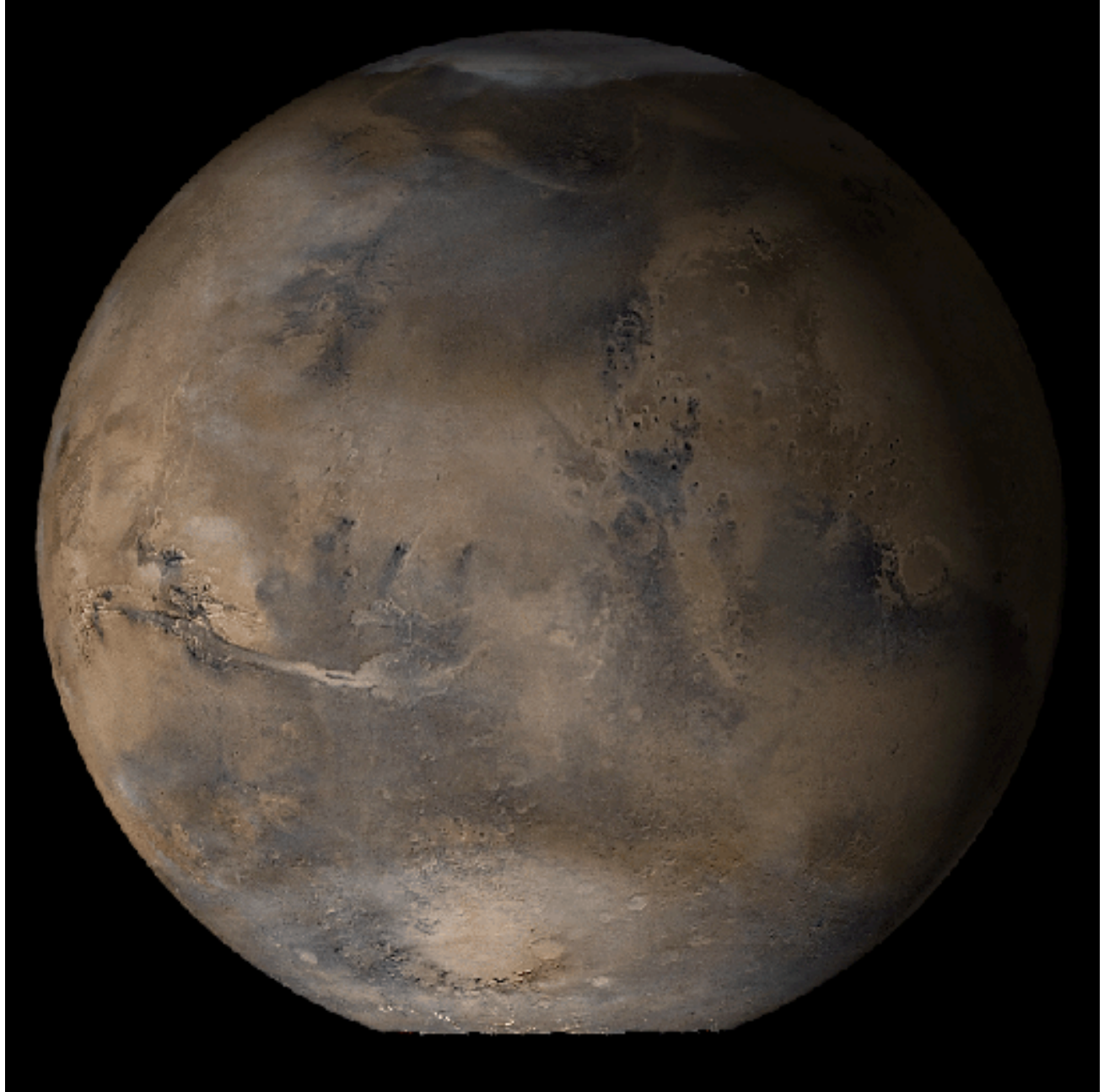

***by Alan J. Friedman and Cary I. Sneider
revised by Toshi Komatsu, Alan Gould,
John Hewitt, and Kevin Cuff***

Red Planet Mars

Mars Global Surveyor circled in a polar orbit, traveling over the Martian north pole to the south pole and back to the north pole once every two hours, twelve times a day, collecting global “snapshots” from 400 km (249 mi) above the martian surface. It contributed to meeting the four main science goals of the Mars Exploration Program:

- (1) Determine whether life ever arose on Mars,
- (2) Characterize the climate of Mars,
- (3) Characterize the geology of Mars,
- (4) Prepare for human explorations. It found signs of past, persistent water such as an ancient delta and currently active water features in the gullies of canyon walls. Delta-like fan on Mars suggests ancient rivers were persistent. Images suggest water still flows in brief spurts on Mars.

From <http://marsprogram.jpl.nasa.gov/mgs/>



Cover and title page photographs of Mars, courtesy of NASA and the United States Geological Survey.

This material is based upon work supported by the National Science Foundation under Grant Number TPE-8751779. Any opinions, findings, and conclusions or recommendations expressed in this publication are those of the authors and do not necessarily reflect the views of the National Science Foundation.

Original edition: Copyright © 1990, by The Regents of the University of California.

Revised editions, copyright © 1993, 1999, 2002, 2009 by The Regents of the University of California. 2002 edition designed and edited by Andrea Colby, published by Learning Technologies, Inc.

This work may not be reproduced by mechanical or electronic means without written permission from the Lawrence Hall of Science, except for pages to be used in classroom activities and teacher workshops. For permission to copy portions of this material for other purposes, please write to: Planetarium Director, Lawrence Hall of Science, University of California, Berkeley, CA 94720.

The original edition printing of the Planetarium Activities for Student Success series was made possible by a grant from Learning Technologies, Inc., manufacturers of the STARLAB Portable Planetarium.



Lawrence Hall of Science
www.lawrencehallofscience.org

Planetarium Activities for Student Success

For latest information, valuable links, resources relating to the PASS series, visit:

www.planetarium-activities.org

Red Planet Mars

Contents

Introduction	4
Materials.....	4
Set-Up	8
Recommendations for Using the Script	10
Planetarium Show Script	11
Introduction to Red Planet Mars.....	11
Finding Red Stars Activity.....	11
Find the Planet Activity.....	12
Telescope Views.....	13
Telescope Observing and Sketching Activity	14
Lowell and Canals	15
Views of Mars from Orbit.....	16
The Surface of Mars	17
The Space Telescope and Canals.....	19
Exobiology Activity	19
Science Fiction Martian.....	21
Modern Mars Exploration	22
Discover More About Red Planet Mars.....	26
Worldwide Web / Updates, Books, Articles	
Acknowledgements	27

Introduction

Red Planet Mars was designed for public audiences and school children in grades four and above. With some adaptation, it could be presented to slightly younger groups as well.

The purpose of the program is not to tell the students all about Mars, but to enable them to make their *own* discoveries about the red planet. Through a series of activities, the students gain an understanding of planets and how astronomers investigate them.

In the first activity, students identify Mars as the ancient Greek astronomers did, by observing its motion from night to night as it wanders among the “fixed” stars. Next, slides are used to show how Mars looks through a telescope. A special effect or movie simulates the changing, distorted view caused by the Earth’s atmosphere, students are invited to sketch a map of Mars. Discussion of their own maps provides a jumping-off point for the instructor to introduce the Great Canal Debate, which astronomers waged during the first half of the twentieth century.

The science of “exobiology,” still very much alive today, provides the rationale for the next activity: inventing a creature which might have evolved on a Mars-like planet. The program concludes with the modern space scientists’ view of Mars, images captured by recent NASA missions to Mars, and a look towards the future exploration of Mars by spacecraft and by humans.

We would be very grateful to hear from you about how you used this program, what modifications you made, what worked well, and what didn’t work well.

Materials

1. Images.

This program is a real challenge to keep up to date for the “Modern Exploration” section. If possible, include some “latest” images of Mars. Images are listed on page 7, with sources on page 8. With the exception of the Lawrence Hall of Science and NASA images, the photographs are copyrighted. Optional eyepiece ring, image 2, is intended as a frame for images 1 (in conjunction with the “Fuzzy Mars” activity) and image 3. The eyepiece ring is projected first, and then “filled” with the telescope images as desired.

Optional

An extra dimension may be added to the show by adding a few extra images that compare the spacecraft images of Mars with LANDSAT images of Earth. Specific features that are interesting to compare with suitable Earth features are: dunes (image 12), river valley (images 13 & 20), and volcanoes (images 21 & 22). This option may be particularly worthwhile for students who are totally unfamiliar with the appearance of such features in high altitude photos. The added high altitude Earth images may provide a valuable additional experience to enhance their appreciation of the Mars images.

Objectives

After attending the program, students will be able to explain that:

1. Planets and stars look similar at first glance with the unaided eye.
2. Some stars are reddish, as is Mars.
3. Planets can be detected by noting their motion against the background stars.
4. Atmospheric interference blurs the view through a telescope.
5. Several different observers may report conflicting aspects of a phenomenon poorly observed, and yet may all be reporting useful information.
6. Exobiologists imagine forms of life adapted in specific detail to the planets other than earth.
7. Spacecraft missions have vastly increased our knowledge of Mars, but have found no clear signs of life.

Jeff Nee, former staff person at The Lawrence Hall of Science planetarium, has created two new programs inspired by the original Red Planet Mars program, but containing many more recent images: Life on the Red Planet and The Art of Mars. And here is Jeff’s Red Planet flat media

2. Telescopic Mars Projector.

This is an effect that shows a telescopic view of Mars that shimmers as if due to the Earth's atmosphere. For digital planetariums use a movie of the Telescopic Mars effect in the media files - v6RPM0fuzzymars.mp4

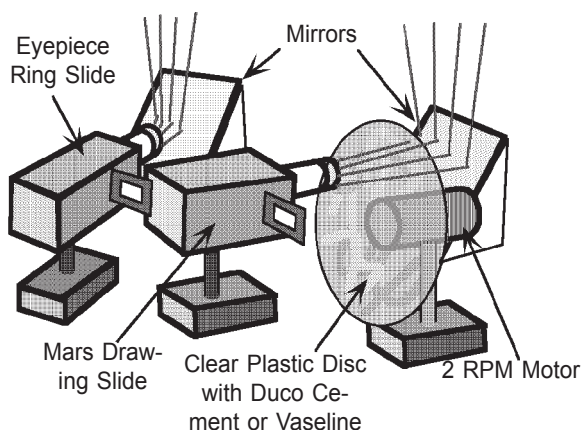

The pre-digital, pre-video version of the Red Planet show employed a special effect device invented by Sheldon Schafer of Lakeview Museum Planetarium, Peoria, Illinois. It consisted of a slowly rotating transparent plastic disk placed in the projected beam of any slide projector (see diagram). The disk was thinly smeared with Duco cement or Vaseline, with some areas kept clean to produce moments of clarity. The effect was quite accurate. We used a disk 20 cm. diameter glued to a 2 r.p.m. motor. As a simpler alternative, the disc can be mounted on an arm attached to the slide projector and moved by hand. We projected a slide drawing of Mars made by Charles Capen, which was available commercially from the Hansen Planetarium, Salt Lake City, Utah.

3. A Naked-eye Mars.

This is needed for the first activity. The starlike image of Mars must be moveable and similar in diameter and hue to the other red stars in the planetarium sky. For digital and modern opto-mechanical projectors, the normal Mars planet projector should work fine. Some planetarium projectors include a good Mars projector that can be adjusted by hand. However, if your projector produces planets much greater in diameter than the stars, you can use a single “dot” projector for Mars. We have used a simple black Kodalith slide with a small orange dot which projects a star similar to the first magnitude stars in the planetarium sky. The single slide projector was moved by hand to produce the two or three relative motions that occur (during the “weeks”) in the program.

4. An Activity Sheet, Clipboard, and Pencil.

This sheet for each member of the audience provides space for them to draw their versions of Mars, and for their extraterrestrial creatures. You can devise your own sheet or use ours (p. 9). We also provide a clipboard with attached pencil for each participant.

5. Battery-operated light pointers.

Have at least two light pointers (one bright and one dim) or a single light pointer with variable brightness. There are a number of options for light pointers. Laser pointers can work OK, but they tend to be too bright for pointing out dim stars. If you use laser pointers, make sure to have one or more low-power dim ones in addition to a bright one. It's possible to make an inexpensive light pointer out of an LED flashlight—see *Constellations Tonight*, PASS volume 5.

6. Reading lights for the students.

In our permanent planetarium, we have 7-watt night-light orange bulbs under the cove, with shades so they shine down on the audience. This is very convenient, because visitors can draw on their activity sheets and look back up at the sky easily. The program can also be done by turning up the daylight for people to study their charts, and then turning it down for sky examination. In our portable inflatable planetarium, we use 7-watt night-light orange bulbs in clip-on lamps, mounted to shine down on the audience for reading and drawing.

7. (Optional) A Document Projector.

This allows participants to have their own drawings projected onto the dome for discussion. In the pre-digital era, such devices were called opaque projectors.

Image List

IMAGE NAME	CREDIT
01 Eyepiece Ring	Lawrence Hall of Science
02 Telescope View	ASP/Hansen/Hale
03 Fuzzy Mars or Fuzzy Mars MOVIE	Still by Charles Capen/Hansen; Movie by Komatsu & Gould, LHS
03a Drawings	Optical Data Corporation's "Astronomy" laser videodisc
04 Lowell	Lowell Observatory
05 Lowells Drawing	Lowell Observatory
06 Mariner	JPL/NASA
07 Mars Global View	NASA/JPL/Malin Space Science Systems
08 Global Olympus Mons	NASA/JPL/Malin Space Science Systems
09 Valles Marineris	NASA/JPL/Arizona State University
10 Olympus Mons	NASA/JPL/Malin Space Science Systems
11 Caldera	NASA/JPL
12 Gullies	NASA/JPL/University of Arizona
13 Viking Lander	NASA/JPL
14 Viking Digs	NASA/JPL
15 Mars Meteorite	ASP/NASA/Finley-Holiday
16 HST Views	Univ. of Colorado/Cornell University/Space Science Institute/NASA
17 Red Hop Flier	Bonnie Dalzell*
18 Green Carnivore	Bonnie Dalzell*
19 Ribbon Fish	Bonnie Dalzell*
20 Bandersnatch	Bonnie Dalzell*
21 Pauls Martian	Frank R. Paul, May 1939 Fantastic Adventures, back cover
22 Pathfinder	NASA/JPL
23 Martian Rocks	NASA/JPL/Johns Hopkins University
24 Water At Pole	NASA/JPL/ASI/ESA/Univ. of Rome/MOLA Science Team/USGS
25 Mars Exploration Rovers	NASA/JPL/Cornell University
26 Spirit	NASA/JPL/Cornell
27 Opportunity	NASA/JPL-Caltech
28 Blueberries	NASA/JPL-Caltech/Cornell/USGS
29 Caves	NASA/JPL-Caltech/ASU/USGS
29a Dust Storms MOVIE	NASA/JPL/Malin Space Science Systems
29b Olympus Mons MOVIE	ESA/Hubble (http://www.spacetelescope.org/copyright.html)
29c FlightThru MarinerValley MOVIE	NASA/JPL/Arizona State University
30 Geologist	NASA

Additional exobiology artwork is available in the media files. Art by Danielle Futselaar <info@artsource.nl>

* Slide Sources are listed on the next page † Optional Images or Movies

Red Planet Mars

*** Slide/Image Sources:**

ASP: Astronomical Society of the Pacific, 390 Ashton Ave., San Francisco, CA 94112

Arizona State University: <http://themis.asu.edu/>

Bonnie Dalzell: National Air and Space Museum, Smithsonian (Oct. 1974, pp. 84-91)

ESA Hubble Information Center: <http://www.spacetelescope.org/>

Hansen: Hansen Planetarium, 15 South State St., Salt Lake City, UT 84111

HubbleSite: <http://hubblesite.org/>

LHS: Lawrence Hall of Science, University of California, Berkeley, CA 94720

Malin Space Science Systems: <http://www.msss.com/>

NASA: <http://photojournal.jpl.nasa.gov/>;
<http://www.jpl.nasa.gov/>; <http://mars.jpl.nasa.gov/>

Optical Data Corporation, 30 Technology Dr., Warren, NJ 07060, 800-524-2481

Wikipedia: <http://commons.wikimedia.org/>

Frank Wu: <http://www.frankwu.com/>

Set-Up

The following checklist is suggested as a guide in preparing for each presentation:

1. Latitude: Home.
2. Precession: Current.
3. Time: Early springtime—Diurnal set so Orion is about 20° above the western horizon and Arcturus about 10° above the eastern horizon.
4. Mars set a few degrees to the right of Regulus in Leo.
5. No other planets visible.
6. Sun and moon off.
7. Slide projectors set for Mars show.
8. NESW lights on.
9. Activity sheet, clipboard, and pencil for each member of the audience.
10. “Mars-under-poor-seeing-conditions effect.”
11. Opaque projector. (Optional)
12. Battery-operated light pointer. (Optional)
13. Title and credit slides on (Slides 1 and 2).

Red Planet Mars

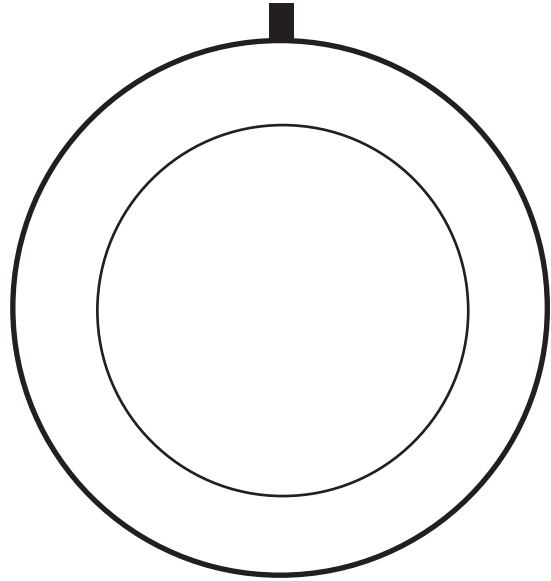
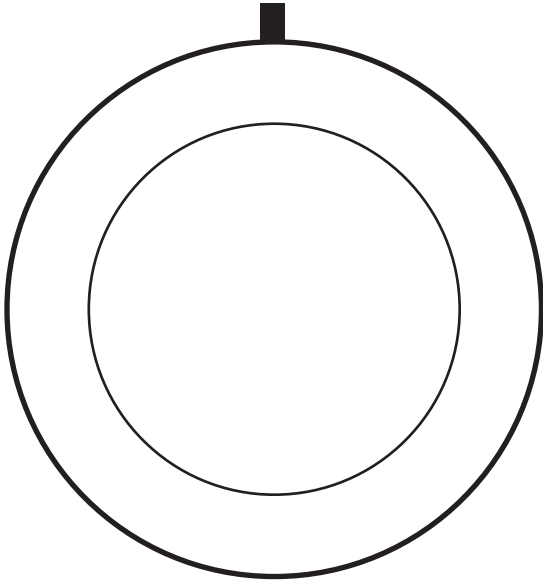

Beings from the Planet Earth



*William K. Holt Planetarium, Lawrence Hall of Science,
University of California, Berkeley, CA 94720*

Beings from a Mars-Like Planet

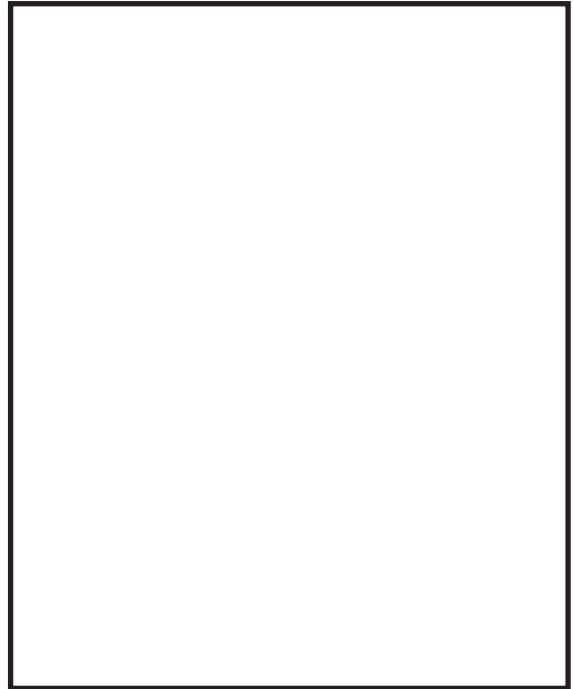

*This planet has: (1) Weaker gravity,
(2) Thinner atmosphere, and
(3) Colder weather than Earth*

Recommendations for Using the Script

We don't expect the script which follows to be memorized (as an actor might memorize a part) but to be used as a guide in learning, rehearsing, and improving presentations. We recommend that you read the script once or twice, then work with it in the planetarium, practicing the projector controls, slides, special effects, and music. You should be able to imagine yourself presenting information, asking questions, and responding to participants. For your first few presentations, you can have the script on hand, using major headings as reminders of what to do next.

The script is organized in blocks or sections. The purpose of these separations is only to help you learn and remember what comes next. Once you have begun a section, the slides or special effects and your own train of thought will keep you on track. When beginning a new section, make the transition logically and smoothly.

Directions for the instructor are printed in *italics* in the side column, the instructor's narrative is printed in regular type, and directions and questions to which the audience is expected to respond are printed in ***bold italics***. There is no point in memorizing narration word-for-word since what you need to say will depend upon the participants. The language you use and the number and kinds of questions you ask will depend on how old the participants are, how willing they are to respond, and how easily they seem to understand what is going on.

We believe that the most important elements of the program are the questions and the activities since these involve the audience in active learning. If you must shorten your presentation, we recommend that you borrow time from the narration.

Planetarium Show Script

Introduction to Red Planet Mars

Welcome. My name is _____, and I'd like to welcome you to the _____ Planetarium. One of the most exciting things about science is that it places you in a position to discover new things. Today, you will have the chance to experience for yourself some of the excitement of discovering new things about the Red Planet Mars. Mars has been "discovered" several times: thousands of years ago, when people first realized that Mars was different from the stars; 400 years ago when people first looked through a telescope; and much more recently when cameras aboard spacecraft began giving us our first close-up views of the surface of the planet. You will be able to make each of these discoveries yourself, today, in our participatory planetarium program, "Red Planet Mars."

It is now evening. As your eyes grow accustomed to the darkness, you will see the sky as it looks in early springtime. Imagine yourself centuries ago, looking up at the night sky.

Finding Red Stars Activity

Can we discover Mars right now? Everybody, please look all around the night sky, and let's see how many orange-red points of light we can find.

Please let me know when you have found an orange to red point of light, so we can point it out to everybody.

Turn up reading lights partially; when people find something let them show it with portable pointers. Keep asking until Mars and two other orange-red objects are found.

We now have three candidates, orange to red points of light that might be Mars. One of them has been designated by every society on Earth as being special. Mars, we call it. But which one of these is Mars?

Is one of these different from the rest? How?

Someone may mention the idea that stars twinkle, but planets have a steady glow. This is not always true; it depends on atmospheric conditions. Even under good seeing conditions, it is often difficult for novice observers to perceive the difference between stars and planets.

Each of these reddish points of light may have some unique quality, but we need an overwhelming difference. They are different through a telescope, but the ancients didn't have telescopes and they still knew which one was Mars.

Find the Planet Activity

Could one of these points of light do something different? We have been watching for many minutes now, and we know all the points of light in the sky appear to turn very slowly throughout the night. But there isn't much happening so far, and no one star stands out yet. Maybe we should go ahead several nights to see if anything has changed.

Assign each object to a section of the audience to watch.

Now study your assigned object carefully. Look at its position compared with the stars around it, so that you will be able to tell if it has moved.

Turn up daylight, turn down stars and planets. Advance Mars about 10 degrees East.

When the lights dim again we will be four weeks in the future, and the stars will be nearly in their same positions. But will any of our orange or red objects be different?

Turn up stars and planets, turn down daylight.

What happened to your point of light?

Go from group to group. Nearly everybody will say theirs moved a little bit.

Well, most of the objects may have moved a little bit. Maybe we need to go ahead another four weeks to tell for sure which one is a planet. Watch your object again.

Turn up daylight, turn down stars and planets. Advance Mars another 10 degrees East, etc.

What happened to your point of light now, eight weeks after we started?

Now a few will have decided theirs did not move, but the Mars group will be sure that theirs did move.

We are not sure about some of the objects but have ruled out some, and one group thinks this one (Mars) definitely did move. Perhaps members of that group would venture a prediction as to where the object will be in another 4 weeks.

Allow a member of the group to use the pointer to show where they think it will move.

Let's all watch their object very carefully this time and see if it indeed moves against the background of stars.

Repeat 4 week motion sequence a final time.

Did it move? [Yes.] Is it where you predicted it would be?

So we have found the planet Mars by its motion, the same way the ancients did. In fact our word “planet” comes from the Greek word “planetes,” meaning “wanderer.” Because the Earth is turning, all the stars and planets appear to move slowly every night, together. The planets, due to their motion around the Sun, appear to turn a little faster or a little slower than the distant stars. Stars and planets have many other important differences, but we can’t tell without a telescope. The way Mars drifts against the starry background convinced astronomers centuries ago that the planets travel in orbits around the Sun, not around the Earth.

We have found it: that red dot of light is the planet Mars, as people have seen it throughout the ages. We find other celestial objects just as red as Mars in the early spring sky. Here’s Aldebaran in Taurus, for example, and Betelgeuse in Orion — both are red-giant stars (point out the red stars named). Following the curve of the Big Dipper’s handle leads us to Arcturus, in Boötes (point out). Antares, the name of a red-giant star in the summer sky, means “rival of Mars.”

Telescope Views

We have discovered Mars just as it was when it was first discovered: using our unaided eyes. Just about 400 years ago, Galileo discovered a new way of looking at Mars: through a telescope.

Optional Image 1: Eyepiece Ring ▶

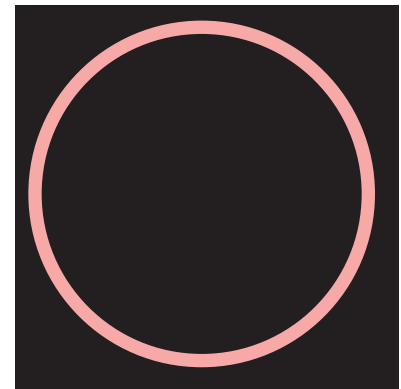

Image 2: Mars Through a Telescope ▶

This red circle represents the eyepiece of a telescope, and we are looking at one of the clearest photographs ever taken of Mars through a large telescope on the Earth.

What features do you see in this photograph? [Color, dark shapes, white polar cap.]

The features—the light and dark areas—are not so very sharp. In fact, they are kind of blurry.

Why do you think that this picture looks so blurry? [Atmospheric turbulence on Earth.]

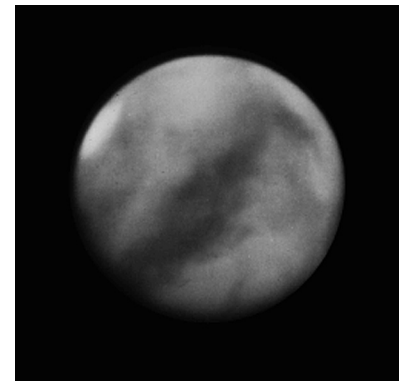

Now we’ll see Mars as it would look through a large telescope.

Image 3: Fuzzy Mars (effect or movie) ▶

Turn on Special Effect or Fuzzy Mars movie.

There it is. See how our atmosphere is changing, blurring the image. But every once in a while the atmosphere will stabilize, and Mars will become clear for an instant. This is a very accurate simulation of the “live” view through a large telescope.

Any photograph we take through any telescope on Earth must also look through the constantly changing atmosphere of the Earth. The turbulent air makes stars twinkle, and planets look blurry. Every minute or so on very clear nights the atmosphere directly along our line of sight may hap-



Red Planet Mars

pen to be less turbulent than normal, and for a fraction of a second, we might get an unusually clear view. But cameras don't know when these moments will occur, and record the picture over several tenths of seconds, so they would photograph the blur along with the clear. So astronomers observing from the Earth even today rely on their eyesight and memory, and sketch details by hand.

There are some fine details in this view of Mars that I can just barely make out. As astronomers, we would try to establish as much detail as possible by seeing if there are any visible features we all agree are real.

Telescope Observing and Sketching Activity

Here is your chance to pretend you are an astronomer, trying to help decide what the surface features are. Let me give each of you a piece of paper. On the top half there are two sketches of your telescope eyepiece, with a blank disk of Mars ready for you to complete.

Now, to help determine what surface features are there, please sketch in the dark features on the surface of Mars. Watch for the brief moments of clarity, and then get as much detail as you can.

We will observe for just a few minutes, and then hold a brief conference to reach our joint conclusions. There is a second blank disk on your paper in case you don't like the way your drawing is coming out, and want to start over.

Please recall the telescope photograph of Mars that you saw a few minutes ago.

Which contains more details, your drawings or that photograph?

Any one of your drawings has more detail than that photograph which was one of the best ever taken from the planet Earth.

Compare your sketch with the person sitting next to you. Did they see some details you didn't?

Turn up daylight, distribute paper, turn on reading lights full.

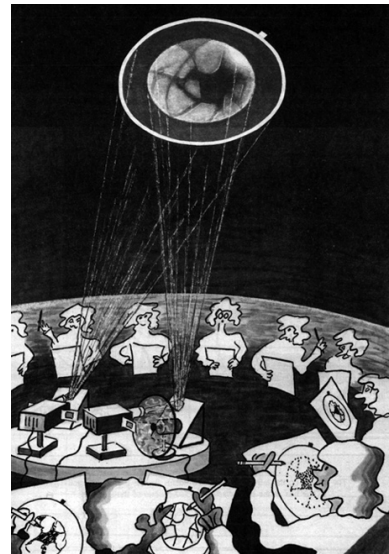

Turn off daylight. Go through three periods of clarity, then turn up daylight and turn off Mars' special effect.

Walk around the room, select one or two examples and show using the opaque projector. These sketches are all different, although some of the features show up on most of them. Ask students to name the features on the projected image that are similar to the features on their own drawing.

Why do you think each of us made a different sketch of the same view? [Differing skills of observers, different moments of observation, different choices of what to watch.]

There are always differing interpretations of what is really there for something as new and difficult to observe as this. We cannot agree perfectly on what is really there, but we can come to agreements on broad structure. Even with all the inherent limitations of drawings, many of the best and most detailed images of Mars have come from drawings by amateur and professional astronomers, not from photographs.

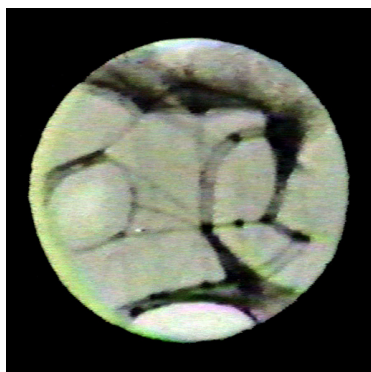

Optional

Optional (movie: RP1drawings.mov) Show the series of comparison images from the Optical Data Corporation's "Astronomy" laser videodisc or slides, showing first a telescope photograph of Mars at a given time, then a corresponding astronomer's drawing of the same side of Mars created at the same time as the photograph. (See image list, page 7.)

Lowell and Canals

Image 4: Lowell. ►

Sharp-eyed observers with telescopes discovered the length of a Martian day is 24 hours and 37 minutes — not much more than one Earth day. They measured the planet's smaller size, a little more than half the diameter of Earth. They noticed that many of Mars' mysterious markings seem to darken and lighten as the polar ice caps grow and shrink with the seasons. In 1877, two tiny moons were discovered orbiting close to the red planet. They were named Phobos and Deimos.

One of the most persistent Mars observers was Percival Lowell, an American astronomer in the early part of the 20th century. He observed Mars over and over for many years, and he reported some controversial features that were very hard to see. Let's look at one of his drawings, showing Mars as Lowell saw it.

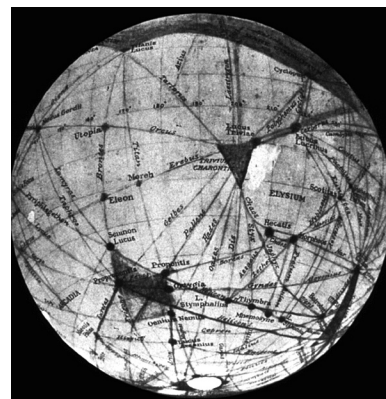

Image 5: Lowell's Drawing. ►

Lowell saw and named hundreds of fine lines criss-crossing the planet. He noted they seemed to connect the poles, which had white caps like the arctic regions of Earth, with the rest of the planet. Many astronomers never could see these fine lines, but several others agreed with Lowell that the lines were there.

If the lines are real, what would you say they might be?

Lowell guessed that the lines were canals, irrigating the Martian deserts. And where there are irrigation canals, there must be canal builders. Thus, Lowell suggested that there was a civilization of intelligent Martians.



Red Planet Mars

Mars has always excited the human imagination, and Lowell's ideas about the possibility of intelligent beings on the Red Planet fired worldwide popular enthusiasm. The canal debate continued on through much of the 20th century. People wondered what the Martians might look like? Would they be hostile, or friendly? The canals of Mars also inspired countless stories, radio plays, movies, and TV shows.

Do you have a favorite story or movie about Mars?

Views of Mars from Orbit

Image 6: Mariner 9 Spacecraft. ►
[Slowly rotate diurnal so it looks as if the spacecraft is moving.]

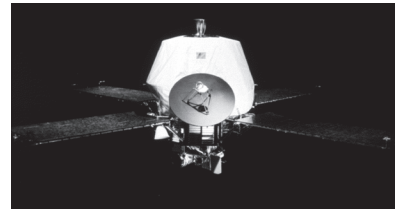

For some or all of the images, ask, "What are we seeing here?"

The Mariner and Viking missions of the 1970s sent us our first high-quality views of Mars from space. In 1976, the Viking Landers gave us our first really close-up look at the Martian surface. In the space age, once more we see the Red Planet in a new way.

When Mariner 9 arrived in 1971, a planet-wide dust storm covered Mars for months, obscuring surface features. Earth-based telescopes have observed such dust storms on Mars.

Optional: Video images of Martian dust storm (see image list on p. 4).

The dust finally settled, revealing giant volcanoes larger than any mountains on Earth, a vast canyon system over 2500 miles long and five times deeper than our Grand Canyon.

Image 7: Mars Global View
[Point out Valles Marineris]. ►

This is a composite of images from Mars Global Surveyor, Mars Orbiter Camera. The huge feature, Valles Marineris, named after the Mariner spacecraft, turns out to be one of the narrow lines drawn on Lowell's canal maps.

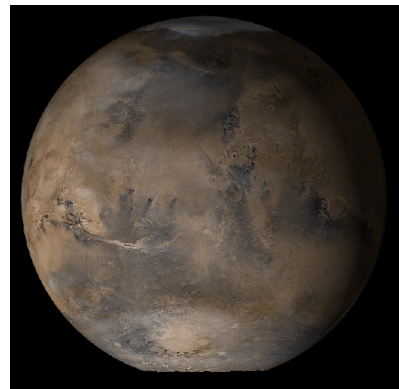

Image 8: Mars Volcanoes— image from Mars Global Surveyor. ►
Point out Olympus Mons.

Here's the largest volcano, Olympus Mons. The Mariner and Viking Orbiter images also show sand dunes, craters from meteor impacts, and striking evidence of water erosion on the Martian surface. Water ice clouds are present over Olympus Mons (right center) and other large volcanoes in the region. The summertime north polar residual water ice cap can be seen at the top of this picture.

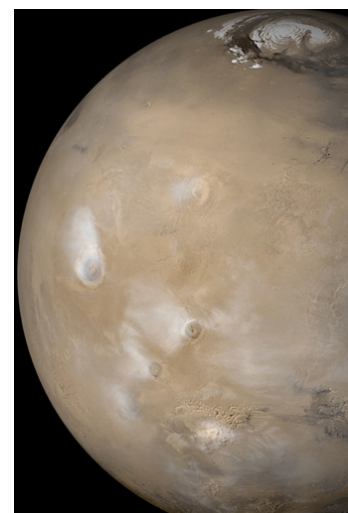
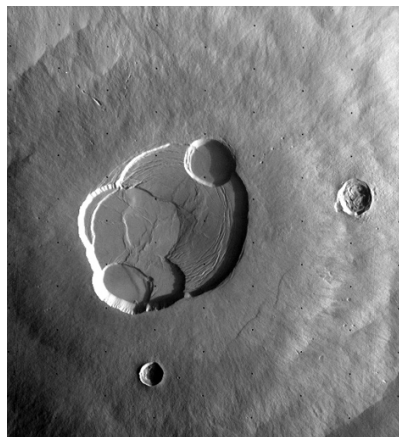
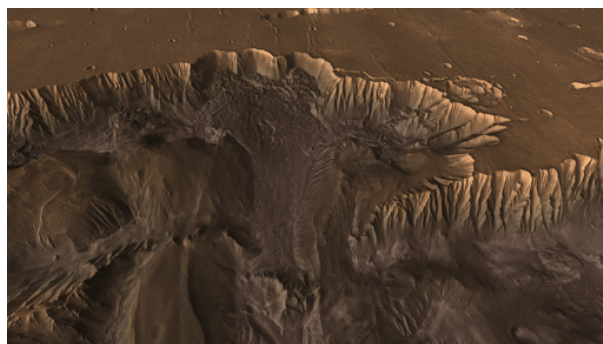

Image 9: Valles Marineris Close-up —data from Mars Global Surveyor. ►

This close-up mosaic of the Valles Marineris was fitted to a computerized topographic model. The entire Valles Marineris canyon system stretches 4,000 km, is 200 km wide, and can be up to 7 km deep.



◄ **Image 10: Olympus Mons — Mars Global Surveyor.**

The base of the Olympus Mons volcano would almost cover the entire state of Arizona! Here we see it from above and from an oblique view.

Image 11: Olympus Mons Caldera — Mars Global Surveyor. ►

Very few meteor craters show up here at the summit of Olympus Mons, so the volcano may have erupted in recent geologic times. Underground, perhaps it is warm enough for liquid water to exist.

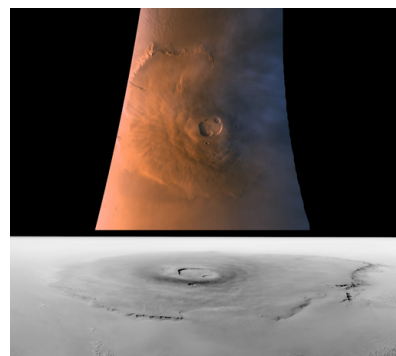
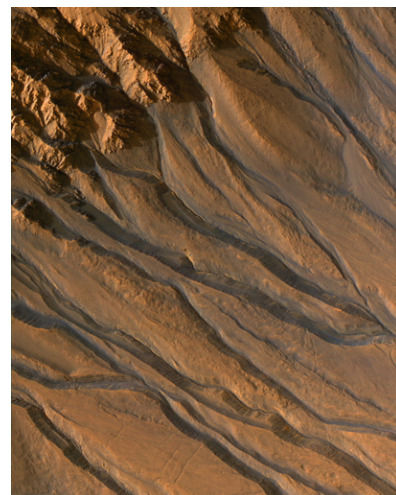

Image 12: Gully Channels in a crater—image from the Mars Reconnaissance Orbiter. ►

Here is a striking picture. *How do you interpret this photo?* These look like water-cut river channels with streamlined islands — but there is no liquid water on the Martian surface now. This raises a very important question: Where did the water come from and where has it all gone? Was the climate on Mars once much more like the Earth, with lakes and oceans in which life could have arisen?



The Surface of Mars

In the summer of 1976, two Viking spacecraft entered orbit around Mars. Two landers detached, descended, and touched down successfully.

Image 13: Viking Lander. ►

Soon, we saw the first photographs ever taken of the Martian landscape and could imagine standing next to one of the Viking landers, with rocks, sand and dust at our feet.

The surface of Mars looks like a rocky desert. There is no running water. The ground is very cold, even though the polar ice caps lie far away. The sky is colored salmon-pink. The air is extremely dry and



Red Planet Mars

thin. Many rocks are covered by a layer of fine red dust. The color of Mars is due to reddish minerals rich in iron-oxide—rust!

Image 14: Viking Digs a Trench. ▶

The Viking Landers each used a robot arm with a scoop at the end to dig into the Martian soil. This image shows how the digging arm gathered soil for experiments. Sensitive instruments on the landers searched for signs of microscopic life, but the results gave no clear evidence that life exists today (or ever has existed) on Mars.

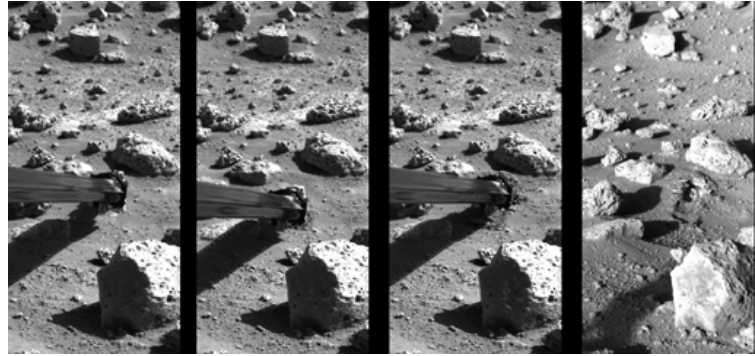

Viking carried out many other interesting science experiments: measuring the weather on Mars, searching for Marsquakes, analyzing the air and the soil, and looking for magnetic particles. Mars' atmospheric pressure is only 1/100 that of Earth, and the air is mainly carbon-dioxide. The average temperature on a midsummer afternoon is 30 degrees below zero, Celsius. Dry ice can easily form on the Red Planet's surface, especially in the south polar winter!

The Viking results tell us that Mars' environment today is even more hostile to life than we had thought from Earth-based observations. Still, the Vikings landed far from the ancient river channels, canyons, and polar ice caps. Might we yet find traces of microorganisms or even fossil remains of past lifeforms elsewhere on Mars?

Optional: Martian Meteorite

One intriguing possibility is that we may already have discovered evidence of ancient life on Mars embedded in a Martian meteorite

Image 15: Mars Meteorite.

▶

The Viking analysis of Martian soil allows us to identify the Red Planet as the origin of a few rare meteorites such as this one, the Allan Hills meteorite (ALH 84001). A huge impact on Mars sixteen million years ago blasted fragments spaceward; and this one fell to Earth some 13,000 years ago. It was found in Antarctica. What a stroke of luck that we have found a new way to explore Mars with pieces of it dropping so “conveniently” to Earth.

Could these tiny, tube-like structures inside the Allan Hills meteorite be fossilized bacteria? [Maybe.]

If so, they may have been alive on Mars several billion years ago! This idea is both tantalizing and controversial. The only way to settle the mystery is future expeditions to the Red Planet.

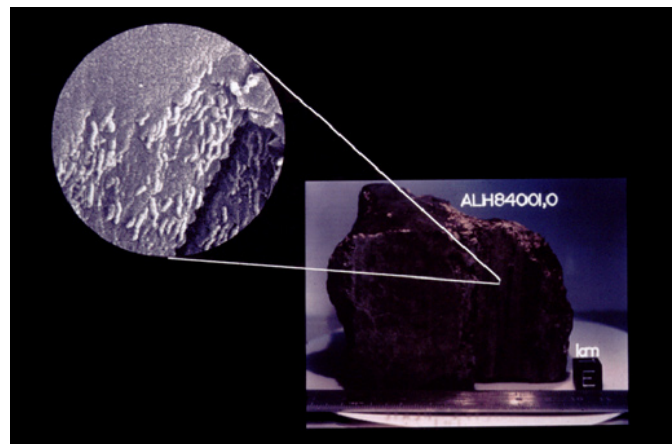

The Space Telescope and Canals

In the space age, there are so many exciting new questions about the Red Planet! But whatever happened to the famous canals, the long straight lines that Lowell imagined must be giant irrigation channels carrying water to Martian farms? Only a few features photographed by spacecraft, such as the “grand canyon of Mars,” Valles Marineris, correspond to any of the narrow lines on Lowell’s canal maps.

Image 16: Space Telescope Views of Mars. ►

This global view of Mars was taken by the Hubble Space Telescope, and shows almost the entire surface of the Red Planet. The Hubble Space Telescope images are far sharper than any ever taken from Earth, and they show details smaller than any Earth-based observer sees.

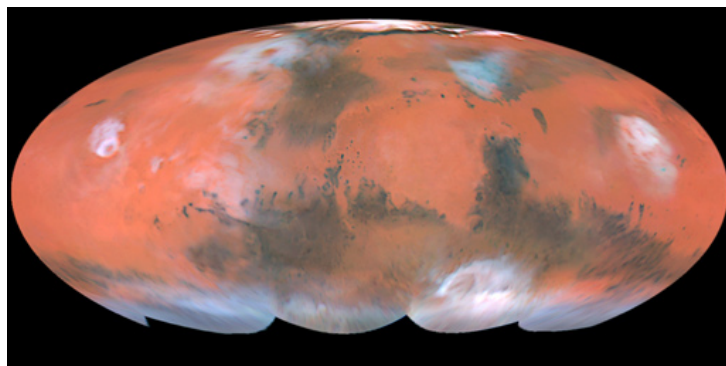

Do you see a network of narrow lines that looks like the canal map Lowell drew? [No.]

You have seen how hard it is to see details on Mars telescopically from Earth’s surface. Very few other astronomers could see all the lines Lowell drew. As long as we had to look up through Earth’s blurry atmosphere, we could never see Mars clearly enough to be certain about the canals. Now we can see Mars clearly, any time we choose, from Earth orbit. We cannot see Lowell’s canal network.

Lowell did a lot of very valuable work in planetary photography, studies of nebulae, and determination of the rotation rates of the planets. He popularized many imaginative ideas about the possible forms of life on other worlds. But his observations of Martian “canals” were not correct. Apparently, the human mind “helps” the eye by filling in details that the eye only partially sees.

Exobiology Activity

The idea of intelligent beings on Mars sounds as fantastic to us today as it did a century ago, when Lowell and others suggested it. But 20th century space exploration has revealed Mars as a world of exciting new possibilities for life: as a potential abode of life in the past, perhaps still harboring life which has adapted to the increasingly harsher environment.

The idea of intelligent life existing somewhere in the universe besides Earth is a very reasonable one, an idea that many scientists today share. Beyond our star, the Sun, there are billions of other stars in our galaxy that may support other forms of life, even intelligent life. We’re only just beginning to discover planets around other suns.

Scientists today who investigate the possibility of life on other planets are called **exobiologists**. Exobiologists try to determine what life forms might exist on other planets with conditions different from those on Earth. Exobiologists studied the kinds of life that could exist on Mars,

Red Planet Mars

so that they could design spacecraft like the Viking, that would be able to search for this possible life.

Let's examine some modern exobiology. We are going to see several creatures designed by exobiologist Bonnie Dazell for an exhibit at the National Air and Space Museum of the Smithsonian Institution in Washington D.C. These imaginary creatures have special features that have evolved to help them survive on planets other than Earth.

Image 17: Red Hop Flier. ►

This is a Red Hop Flier. It's the kind of creature we might expect on a hot planet with low gravity. There, a hopping creature would be able to travel a good way on a single hop, and assisted by his thin wing, the Red Hop Flier gets around nicely.

Does the shape of the Hop Flier's wing look at all familiar? Where have you seen that shape before?

Hang gliders on Earth look very similar. Although air is thinner on a low-gravity planet, the laws of aerodynamics are the same, and a delta wing is a good design. The big wing is good for flying, and the veins help cool his blood on this hot planet.

Image 18: Gliding Green Carnivore. ►

By contrast, this creature glides on a high-gravity, thick atmosphere planet. He needs less wing surface for his body mass. Even with six legs, however, he does not hop far due to the high gravity.

Image 19: Outrigger Ribbon Fish. ►

Here is a huge fish by Ms. Dazell designed for a planet with lots of ocean and very high gravity. The creatures this fish seems to be eating may be about the size of whales!

Why would the largest animals on a high-gravity planet probably be found in the ocean? [Hint: Where are the largest mammals found on Earth? Whales live in the sea, because the buoyancy of their bodies in the water reduces the great internal strength that's needed to keep such a huge creatures from collapsing under gravity's pull.]

Image 20: Bandersnatch. ►

Here is a creature designed for the land of a high-gravity planet.

What features does the Bandersnatch have to help him survive on his high-gravity planet? [Very thick and sturdy neck, ten short and thick legs, large, low mouth to eat plants that grow close to the ground.]

Let's see the kind of imagination necessary to be an exobiologist. Suppose you are trying to decide what possible forms of life might inhabit a planet like Mars.

How is Mars different from the Earth? [It has lower gravity, much thinner atmosphere, and much colder weather.]

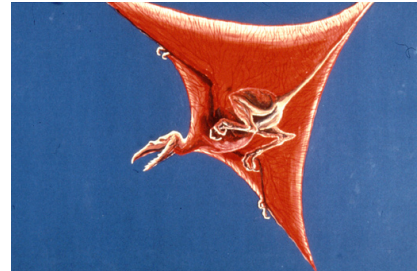

Additional exobiology artwork by Danielle Futselaar <info@artsource.nl> is available in the media files. With her images (creative commons license), you can ask what kind of planet might these creatures be from?

The gravity is only about 1/2 Earth's gravity. Temperatures are below zero most of the time on Mars. Martian atmospheric pressure is only 1/100 that of Earth. Now close your eyes and picture in your mind a creature that would be adapted to lower gravity, colder weather, and much thinner atmosphere.

On the bottom of your sheet of paper is a drawing showing some forms of life that have evolved to meet Planet Earth conditions. They might not be suitable for a Mars-like planet.

In the blank box, please make a rough sketch of the imaginary being that you pictured in your mind that would be adapted to life on a Mars-like planet.

Note: Adults are often shy about this open-ended activity. Encourage them to give it a try. Sometimes injecting humor helps a lot. Give people time to draw. Optional: Play music suitable for drawing Martians. Ask people to compare their ideas with their neighbors. Answer any questions you can. When most people have finished, go around and show a few drawings (using opaque projection if available), asking people to explain what survival features their Martians have. Compliment clever adaptations.

Science Fiction Martian

Your drawings are good speculation. Modern scientists are working on very similar concepts in the quest for life on other worlds! Meanwhile, in classic science fiction stories and films Martians will always be with us.

Image 21: Paul's Martian. ►

What do you think of this drawing made by an early exobiologist in 1939?

This is what a science-fiction artist, Frank Paul, working with astronomers, imagined Martians might look like.

What features does this being have to help him survive on Mars? [Large ears and lungs for the thin atmosphere; tall and slender legs due to light gravity; fur and retractable nose and eyes for cold temperatures.]

Are there really Martians who would build canals and farm the desert planet? Given what we have learned from Mars exploration missions, does it seem likely that Martians like this exist now on the Red Planet?

We have found no evidence of their existence. But could life have flourished on Mars in ages far more ancient? Could some lifeforms have

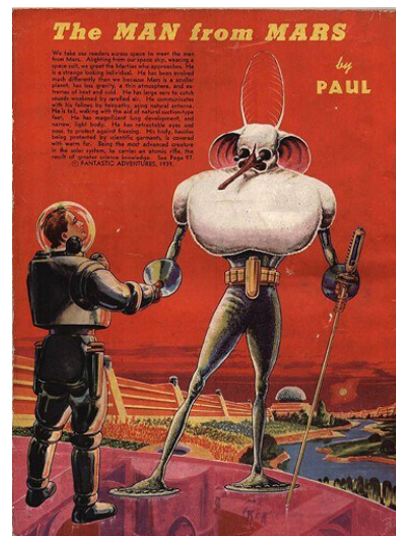

adapted gradually to the harsher environment of present-day Mars? We hope clues to solve these mysteries await us in our future explorations of the Red Planet.

Modern Mars Exploration

Mars once may have been a warmer world, with flowing water, and a much thicker atmosphere. How, why, and when did it evolve to the frigid dry desert planet we find today? To investigate these questions, a new era of robotic exploration began in the late 1990s.

Image 22: Pathfinder and Sojourner. ►

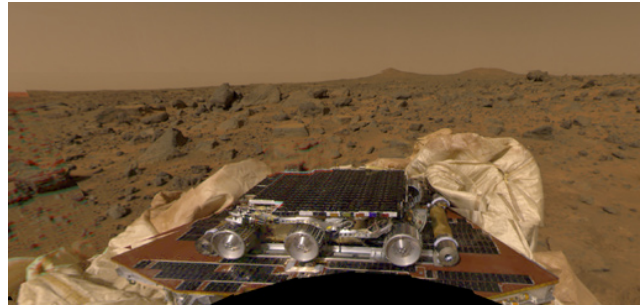

The Mars Pathfinder mission was the first to send a rover to Mars, and was a tremendous success. Its landing site was near the mouth of a vast ancient outflow channel named Ares Valles. There, mission scientists hoped to find a variety of rocks swept together and deposited long ago by catastrophic floods.

Pathfinder's cameras sent back superb color and 3-D views of the Martian landscape, distant hills and dunes, and blue-white clouds of water-ice in the reddish-orange sky at dawn. A small solar-powered robotic rover rolled out on six wheels from the main lander to explore the wind-blown and water-worn terrain, photographing and analyzing the Martian rocks. The rover was named Sojourner after the 19th-century abolitionist Sojourner Truth; while Pathfinder's base was named the Carl Sagan Memorial Station, after the famous 20th-century astronomer Carl Sagan, a leading enthusiast for planetary exploration.

Image 22: Martian Rocks. ►

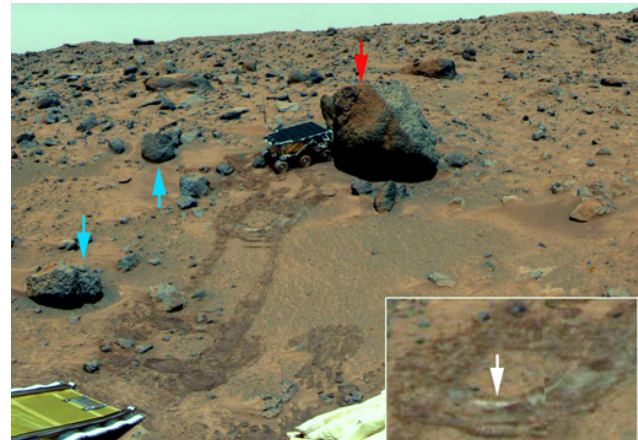

Many of the rocks were named for cartoon characters such as Barnacle Bill. Volcanic rocks are common. Rounded pebbles suggest they were shaped by flowing waters; other rocks are sculpted by winds. Some rocks are distinctly layered, possible evidence of sedimentary deposits in ancient lakes and oceans. Pathfinder left no doubt that enormous floods of liquid water once splashed across the surface of Mars. Long ago, the climate of Mars may well have been warmer, wetter, and more favorable to life's origin.

Inspired by the extraordinary success of Mars Pathfinder, NASA and other countries sent even more missions to Mars.

Mars Global Surveyor was wildly successful. Four years into its mission, it had collected more information about the Red Planet than all previous missions combined. It tracked the evolution of dust storms and gathered high-resolution data on the Martian terrain.

Image 24: Mars' South Polar Region. ►

This map shows the topography of the south pole of Mars. Purple and blue represent the lowest areas, and orange and red the highest. The

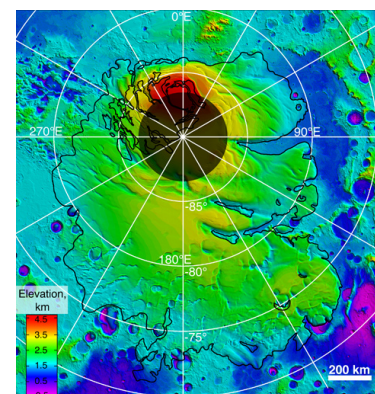

black line shows the boundary of layered deposits of nearly pure water ice. The total volume of ice in these deposits is equivalent to a water layer 11 meters deep, if spread evenly across the planet.

Image 25: Mars Exploration Rovers. ►

Taking the model of the Pathfinder Mission to the next level, the twin Mars Exploration Rovers touched down on Mars in January 2004. These rovers landed on opposite sides of the planet, with identical instruments. While not designed to detect life, the philosophy behind these rovers was to “follow the water.” Both sites showed preliminary evidence of ancient deposits of water from orbital data.



**Image 26:
Spirit on the
Surface. ►**

Like Pathfinder, the Mars Exploration Rovers used airbags to cushion their landing by bouncing. The Spirit rover was the first to land, successfully bouncing and rolling to a stop inside of Gusev Crater. The MER team named the landing site “Columbia Memorial Station,” in honor of the seven astronauts killed in the Space Shuttle Columbia disaster. Spirit very quickly began sending back very high-resolution images of the surface. In this image, a circular feature named “Sleepy Hollow” can be seen, with dark markings—bounce-marks left by the lander.

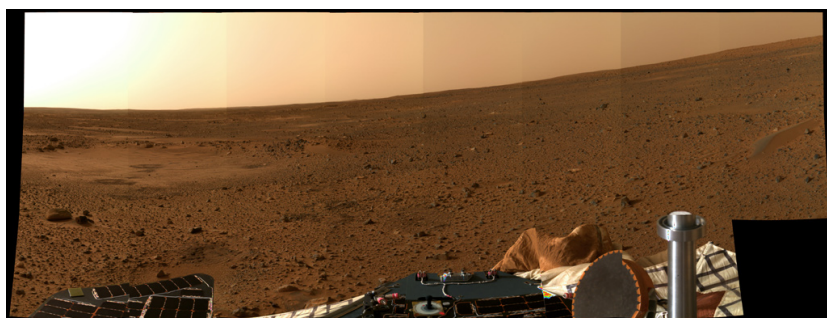
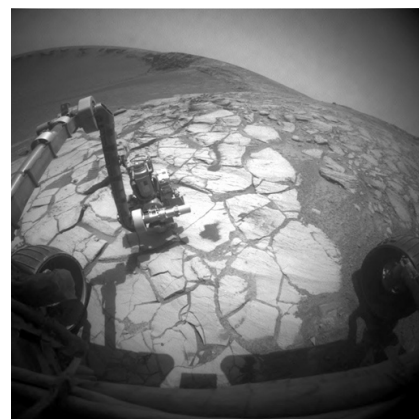

Image 27: Opportunity at Work. ►

Spirit’s twin, Opportunity, made an interplanetary “hole-in-one” when it landed in Eagle Crater—only 20 meters in diameter—in Meridiani Planum. Here Opportunity extends its robotic arm to take samples and measurements on some bright-toned rocks inside of Victoria Crater.



**Image 28: Martian
Blueberries. (v6-
28Blueberries.tif) ►**

One of the most exciting discoveries by the rovers finding “blueberries” near Opportunity’s landing site. These blueberries are about the size of BBs, and are rich in hematite. On Earth, hematite spheres like this are quite commonly formed in wet environments. This, coupled with the fact that these blueberries are found evenly and randomly scattered in rocks (not in layers, as one would expect with a one-time volcanic or meteoric event) provides greater evidence that Mars was indeed very wet in its past.

Although both rovers were expected to last at least 90 Martian days, both rovers far-exceeded that by lasting well over 1800 Martian days.



Red Planet Mars

The 2001 Mars Odyssey Orbiter mission arrived in Mars orbit in October 2001. Its mission is to hunt for evidence of past or present water and volcanic activity on Mars. It also acts as a relay for communications between the Mars Explorations Rovers and Earth, and looks for year-to-year differences in phenomena like polar ice, clouds and dust storms.

Image 29: Cave Skylights on Mars. ▶

In September 2007, Odyssey discovered “skylights” on Mars—possible entrances to caves. These dark circular features are 100-250 meters across, and were discovered because they are cooler than the surrounding surface during the day and warmer at night. The “Seven Sisters” shown here are entries to the subsurface of Mars. Could they be habitats for life? Perhaps not these—due to their extreme altitude on the slope of a volcano—but maybe other caves like these somewhere else on Mars could have provided protection or past—or maybe even present—life on Mars. They may even provide shelter for future human missions to Mars.

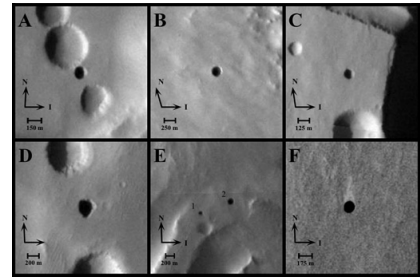

Optional: Video image 29a (movie) Dust storms on Mars (video: RP2duststorms.mov)

We have now been able to record—ever since the Mariner missions—gigantic dust storms that have encircled the Red Planet. These dust storms make it difficult or even impossible to observe any surface features. A global dust storm like this one actually endangered the Mars Exploration Rover mission for a time. Since the dust was so thick and prevailed for so long, the mission team was worried the solar panels would not be able to provide enough power to rovers to operate.

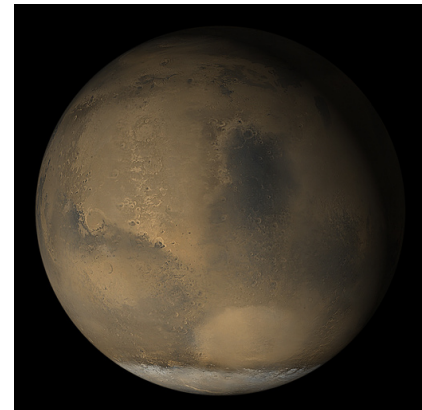

Optional: Video image 29b (movie) flight around Olympus Mons. (video: RP3olympusmons.mov)

Using the data from various spacecraft and some pretty fancy 3-D computer animation techniques, NASA imaging scientists have allowed us to “fly around Mars,” and “land on Mars.” What you see here is a motion picture of what it would look like if you were in an airplane flying around Olympus Mons, the largest volcano in the Solar System. Olympus Mons is almost three times the height of Mt. Everest. At the summit of the caldera, we see three hypothetical future Martian observatories. It is experiences like this, in addition to the enormous wealth of new knowledge, that make our space program so exciting and so well worth our support.



Optional: Video image 29c: “Flight Through Mariner Valley” from JPL (video: RP4vallesmarineris.mov)

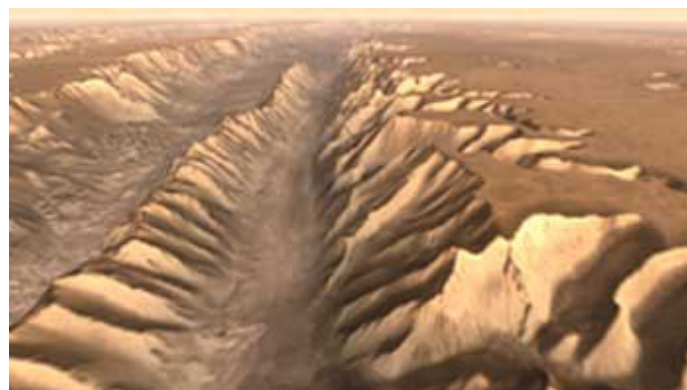

Excerpted Narration:

...The valley walls run far into the distance. Its cliffs and ridges were born through earthquake faulting, the main geologic force that began to open the valley, billions of years ago.

Tucked in the valley's widest part—Melas Chasma—are many layers of dust, sediments, and rock. Each records a slice of time and fills a few pages in the geological record.

Ahead lies a catastrophic landslide that crashed down 15,000 feet, and shot debris nearly 100 miles across the valley floor. Beyond the landslide lies another basin containing more layered deposits. These offer glimpses of the past and record part of the valley's complex geological story.

Farther into the basin, the floor is covered by hills made of layered sediments whose origin remains a puzzle. Winds blowing for millions of years sculpted the soft ground into long ridges.

Turning up a narrow canyon and sailing over a gullied ridge, we fly into Ophir Chasma. Here lie more sediments, wind-carved ridges, and a steep wall, with rock rubble heaped at its foot. A long parade of landslides widened the valley, collapsing walls made of hard, volcanic rock.

A flight through Mariner Valley gives us an exciting glimpse of its geological complexity. Buried in the rocks of this Grand Canyon of All the Planets lies a history book of Mars that scientists have just begun to open. One day, perhaps soon, we'll read the full story of this awe-inspiring place.

Optional: Video of Mars flyover, from *The Planets*, narrated by Patrick Stewart — source is NASA/JPL.)

Optional: Internet Images of Mars.

Display recent images from Mars missions. As of spring 2009, several missions are active on or orbiting Mars—Mars 2001 Odyssey, Mars Express, Spirit, Opportunity, Mars Reconnaissance Orbiter, Phoenix. It's simply impossible to keep this planetarium show up-to-date without bringing in some of the latest images and findings from the Internet.

Image 30: Geologist on Mars. ►

Perhaps one of you will be among the first to land on Mars. Then, we will be the Martians! We will discover and experience Mars in many new ways. Imagine yourself looking up into the evening sky of Mars. Earth looks like a bright, blue-white star in the night, just a tiny dot of light drifting slowly through the constellations.

And, there is certainly no reason for exobiology to stop at Mars. There are hundreds of billions of stars in our galaxy alone. There may be countless planets similar to the Earth and Mars. The Red Planet already has taught us much about how planets form, how they behave, how they can change, and how to look for possible life forms... The search for life in the universe continues!

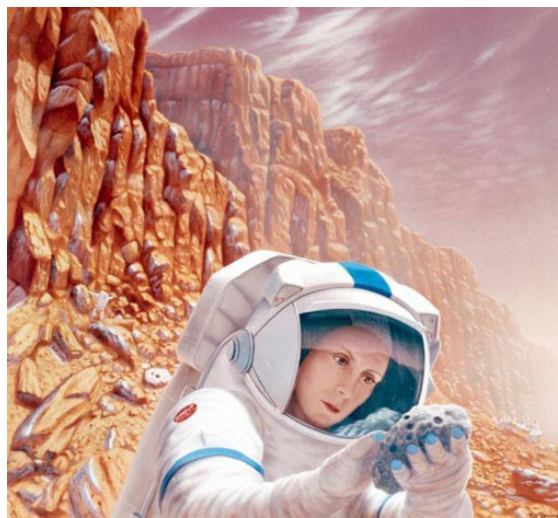

Discover More About Red Planet Mars

Worldwide Web / Updates:

Red Planet Mars update page

<http://www.lawrencehallofscience.org/pass>

NASA Mars Exploration homepage <http://mars.jpl.gov/>

Books

Beatty, J., et al, eds. *The New Solar System*. 2nd ed., Sky Publishing & Cambridge University Press, 1982.

Carr, M. & Greeley, R. *Volcanic Features of Hawaii: A Basis for Comparison with Mars*. U.S. Government Printing Office, NASA Special Publication # 403, 1980; also *The Surface of Mars*, Yale U. Press, 1981, and *Water on Mars*, Oxford U. Press, 1996.

Cooper, Jr., Henry S.F., "Profile: Carl Sagan — A Resonance with Something Alive," *New Yorker*, June 21 & 28, 1976. On research for life elsewhere. Cooper, H. *The Search for Life on Mars*. Holt, Rinehart & Winston, 1980.

Ezell, E. & L. *On Mars: Exploration of the Red Planet 1958-1978*. U.S. Government Printing Office, NASA Special Publication # 4212, 1984. A history of the Viking project.

French, Belvan M., *Mars: The Viking Discoveries, NASA, 1977*. A well illustrated, non-technical booklet summarizing the complete Viking project and its major results.

Goldsmith, D. *The Hunt for Life on Mars*, Dutton/Penguin, 1997.

Hawkes, N. *The New Book of Mars*, 1999. Illustrated by Richard Rockwood. CopperBeech/Millbrook. 32 p. Excellent overview of Mars. The Mariner, Mars Pathfinder, and Surveyor '98 missions, as well as planned future explorations, are well described.

Horowitz, N. *To Utopia and Back*. Freeman, 1986. On the search for life on Mars with the Viking instruments.

Hoyt, William Graves, *Lowell and Mars*, University of Arizona Press, 1976. Biography of Percival Lowell illuminates the excitement and controversy over Lowell's contributions to planetary astronomy, including his ill-fated speculations about Martians.

Morrison, D. and Owen, T. *The Planetary System*, 2nd Ed. Addison Wesley, 1996.

Powers, R. *Mars: Our Future on the Red Planet*. Houghton Mifflin, 1986. A polemic for manned exploration.

Sagan, C. *Pale Blue Dot*. Random House, 1994.

Sheehan, W. *The Planet Mars*. U. of Arizona Press, 1996.

Wells, H.G., *War of the Worlds*, 1896. Wells imagined an invasion from Mars, based on the latest theories about the red planet from astronomer Percival Lowell. This fascinating novel started modern science fiction on its way.

Articles About Mars

Arvidson, R., et al. "The Surface of Mars" in *Scientific American*, Mar. 1978.

Bell, J. "Mars Pathfinder: Better Science" in *Sky & Telescope*, July, 1998, p. 36.

Begley, S. "Greetings from Mars" *Newsweek*, July 14, 1997, p. 23.

Carroll, M. "Divining on Mars" in *Astronomy*, Feb. 1999, p. 42. Also "The Changing Face of Mars" in *Astronomy*, Mar. 1987, p. 6; and "Digging Deeper for Life on Mars" in *Astronomy*, Apr. 1988, p. 6.

Doody, D. "Three Ships to Mars," *Sky & Telescope*, Dec. 1996, p. 24.

Haeberle, R. "The Climate of Mars" in *Scientific American*, May 1986.

Hartman, W. "Red Planet Rendezvous" in *Astronomy*, Mar. 1998, p. 50.

"An Ancient Martian Lake Bed?" in *Astronomy*, May 1998, p. 24. Also "What's New on Mars?" in *Sky & Telescope*, May 1989, p. 471; and "Viking on Mars: Exciting Results" in *Astronomy*, Jan. 1977, p. 6.

Kasting, James F., "How Climate Evolved on the Terrestrial Planets," *Scientific American*, Feb. 1988. An excellent overview of Venus, Earth, and Mars, providing an analysis of the "Goldilocks Problem:" why Venus is too hot, Mars too cold, and Earth just right.

Kluger, J. "Space: Uncovering the Secrets of Mars" in *Time*, July 4, 1997, p. 30.

Naeye, R. "Blazing Trail to the RED PLANET" *Astronomy*, Oct. 1997, p. 48.

Naeye, R. "Red Rover" in *Astronomy*, Jan. 1998, p. 42.

Parker, S. "Mars Global Surveyor: You Ain't Seen Nothing Yet" in *Sky & Telescope*, Jan. 1998, p. 32.

Perlman, D. "Ensuring Earthlings Don't Contaminate Mars" in *San Francisco Chronicle*, June 30, 1997, p. A10.

Petersen, C. "Welcome to Mars" in *Sky & Telescope*, Oct. 1997, p. 34.

Portree, D. "The New Martian Chronicles" *Astronomy*, Aug. 1997, p. 33.

Rogan, J. "Pathfinder's 3-D Extravaganza" *Astronomy*, Mar. 1998, p. 62.

Rosenblatt, R. "Visit to a Smaller Planet" *Time*, July 14, 1997, p. 37.

Shibley, J. "Back to Mars on All Sixes" in *Astronomy*, Jan. 1997, p. 48.

Acknowledgements

The following staff members of the Lawrence Hall of Science Astronomy and Physics Education Project tested the first version of this program: Michael Askins, Bryan Bashin, Cynthia Carilli, Cathy Dawson, Gaylord Fischer, Stephen Gee, Mark Gingrich, Alan Gould, Cheryl Jaworowski, Tom Mathis, Bob Sanders, and Budd Wentz. Jill Kangas typed and typeset all of the printed materials in the 1978 edition, and with Larry Throgmorton, edited the final version. Illustrations and graphics are by Budd Wentz, with the assistance of Michael Askins. The NSF grant supporting this work was administered by Lawrence Hall of Science Associate Director Robert Karplus, Principal Investigator for this project. Alan Friedman was Project Director. Special thanks are extended to Alexander Barton and Linda Kahan of the National Science Foundation for their continuing encouragement and support.

In 1988, a grant from the National Science Foundation and Learning Technologies, Inc. enabled us to publish *Red Planet Mars* as part of the *Planetarium Activities for Student Success (PASS)* series. Project Co-Directors were Cary Sneider, Director of Astronomy & Physics Education at the Lawrence Hall of Science in Berkeley, CA, and Alan Friedman, Director of the New York Hall of Science, in Corona, New York. Staff members of the Lawrence Hall of Science who contributed to the series included Lisa Dettloff, John Erickson, Alan Gould, JohnMichael Seltzer, and Michelle Wolfson. Staff members of the New York Hall of Science who contributed to the series included Terry Boykie and Steven Tomecek. Special thanks are due to our Program Officers at the National Science Foundation, Florence Fasanelli and Wayne Sukow.

We wish to acknowledge the assistance provided by our Advisory Board, who helped to plan this series, and commented on early drafts: Gerald Mallon, Methacton School District Planetarium, Norristown, PA; Edna DeVore, Independence Planetarium, East Side Union High School District, San Jose, CA; Philip Sadler, Project STAR, Harvard Smithsonian Astrophysical Observatory, Cambridge, MA; Sheldon Schafer, Lakeview Museum of Arts and Sciences Planetarium, Peoria, IL; Robert Riddle, Project Starwalk, Lakeview Museum of Arts and Sciences Planetarium, Peoria, IL; David Cudaback, Astronomy Department, University of California, Berkeley, CA; and Joseph L. Snider, Department of Physics, Oberlin College, Oberlin, OH.

Perhaps most important are the approximately 100 individuals from around the nation who attended leadership workshops in 1978, and an additional 200 educational leaders who attended three-week institutes in astronomy and space science at Lawrence Hall of Science during the summers of 1989, 1990, 1992, and 1993. These educational leaders provided valuable feedback for their final revision. Their names and addresses are listed the Appendix to PASS Planetarium Educator's Workshop Guide.

In addition, we would like to thank the staff of all of the Astronomy and Space Science Summer Institutes: Joseph Snider, Terry Boykie, John Radzilowicz, John Hammer, Robert Jesberg, Jacqueline Hall, Dayle Brown, Alan Gould, Cary Sneider, Michelle Wolfson, JohnMichael

PASS Volume 6 Photos & Illustrations

- p.2, NASA, 2001 Mars Odyssey (drawing)
- p.5, Alan Gould, Telescopic Mars Projector (drawing)
- p.9, Budd Wentz, Earthling (drawing)
- p.13, Lick Observatory, Mars photo
- p.13 Charles Capen, Mars Drawing
- p.14, Budd Wentz, Mars Drawing Activity (drawing)
- p.15, Lowell Observatory, Lowell photo
- p.15, Lowell Observatory, Lowell's drawing
- pp.16–26, NASA Mars missions—see list on p. 7 for details
- pp.20, Bonnie Dalzell (Smithsonian), Red Hop Flier, Gliding Green Carnivore, Outrigger Ribbon Fish, Bandersnatch
- p.21, Fantastic Adventures, 1939, Paul's Martian

Seltzer, John Erickson, Lisa Dettloff, Kevin Cuff, Debra Sutter, Chris Harper, Kevin Charles Yum, Gregory Steerman, John Hewitt, Edna DeVore, and David Cudaback.

John Hewitt and Jennifer Yim provided valuable assistance in revising the 1999 edition. Toshi Komatsu and Alan Gould revised the 2008 edition. 2003 edition designed and edited by Andrea Colby, published by Learning Technologies, Inc.

The Digital Sky version of this show was made possible through the efforts of LHS staff, Toshi Komatsu, Jeffrey Nee, Laura Scudder, Susan Gregory, and Alan Gould, as well as the staff of Sky-Skan, Inc.: Steve Savage, Ginger Savage, Martin Ratcliffe, Michelle Ouellette, Marcus Weddle, Johan Gijsenbergs, Ed White, Lee Anne Ward, Stephanie Wilson, Paul Tetu, Claude Ganter, Rob Calusdian, Kurt Berna, Geoff Skelton, David Miller, Lou Liberge, Joe Brochu, Ty Bloomquist, and Mike Mertinooke.

Red Planet

Mars