



SLOPING GROUND AND THREE-SIDED SHORING SHIELD APPLICATIONS

Introduction

Shoring shields are intended to be used with level ground on both sides and no ground, (trench only), on both ends. Typical tabulated data for both steel and aluminum shields states that end loading on the struts is not allowed with use under the data. **The installation data also does not address uses where the soil level is different on one side than it is on the other or on one end than the other.** There are a few exceptions to this rule with tab data for aluminum boxes and build-a-box systems where the manufacturer specifically addresses it. Addressing these rules by the manufacturer does not mean that their box is any better or different than others, it just means that their tab data is more user friendly. Most of these situations require OSHA Option 4-Design by a Registered Engineer. This article discusses the installation and engineering issues related to shields in sloping ground conditions and loading on 3 sides only.

Typical tab data notes that apply to this read like:

- The system shall be installed in a manner to prevent lateral or otherwise hazardous movement.

Sloped surfaces present the potential for different loading on opposite sides of the shield and 3 sided only loading leaves one side with no opposing resisting forces.

- Struts shall not be used to support side loading.

This refers to placing plates or timber behind the struts.

Normal Pipeline Shield Applications in Sloping Ground

Normal pipeline shield applications require level ground at least to the width of the excavator because the excavator must sit level in order to dig a vertical wall and level trench bed.



Backhoes can level themselves with their outriggers to some extent. These typical trench surfaces are shown in **Figure 1**

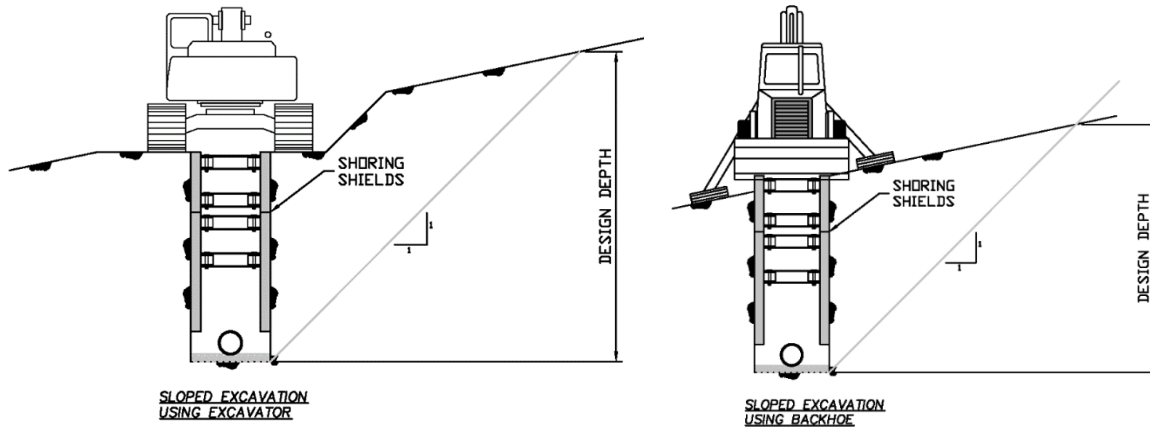

Figure 1- Shield Sloped Pipeline Excavations

The key item for the competent person to understand here is that the loading from the soil is based on the high side of the excavation. A common assumption used by engineers, (not addressed by OSHA), that the loading at the bottom of the excavations is influenced by the height of the soil at a 1:1 distance away from the excavation.

Also note that the excavator at the digging end of the trench rarely adds surcharge loading to the shoring shield, **Figure 2.**, for the most part the surcharge loads on shields come from objects situated along the sides of the shields.

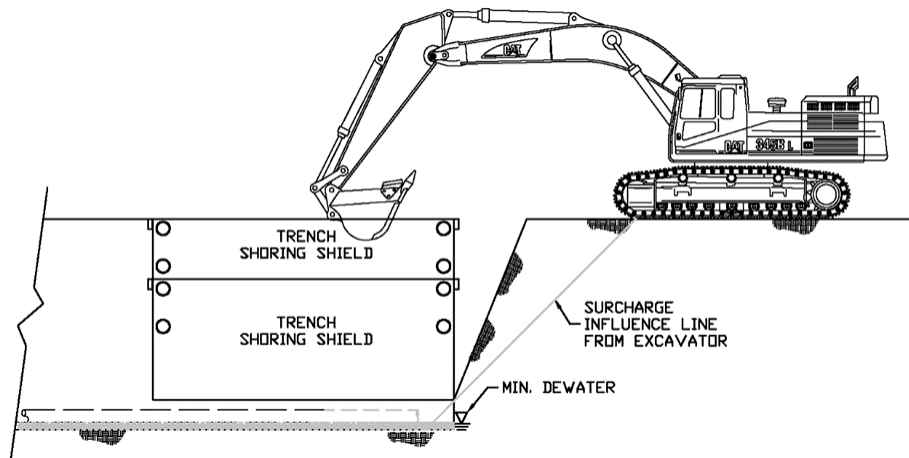

Figure 2- Excavator Influence at End of Trench



Three-Sided Stationary Shield Applications

This situation is quite common with construction of retaining walls and slopes leading into roadway and railway crossings, **Figure 3**.

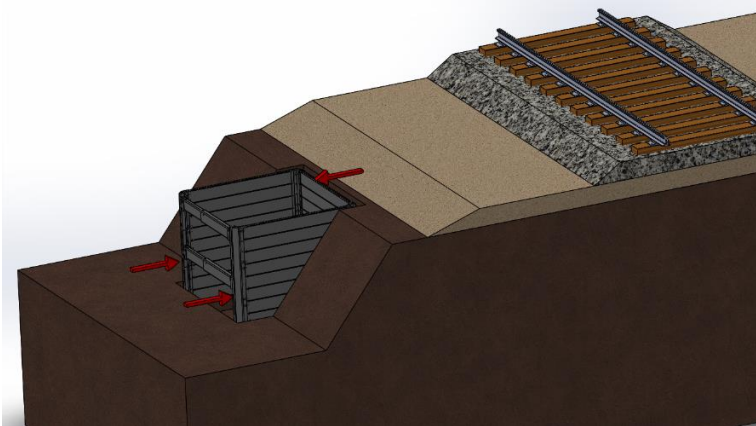

Figure 3- Three-Sided Shield Application

In all three-sided situations the forces on each side of the box must be equal. In Figure 3 the lateral force from the soil and railroad must be resisted by the soil at the open ends. The problem is that at the open ends the resisting area is far less than the area of the back wall. The open ends will just punch into the soil. The photo is an improperly installed three-sided shield application. Typically, this is not a tabulated data situation, it calls for site specific engineering. Aluminum shields, buildable boxes and steel shields are all designed with enough strength to resist the forces generated in these applications. Installing so that the resisting forces are developed is the issue.

There are two basic solutions to this problem. The best way to handle it is to bury the box deeper than the intended work level, this can engage resisting pressure at the front and back wall.

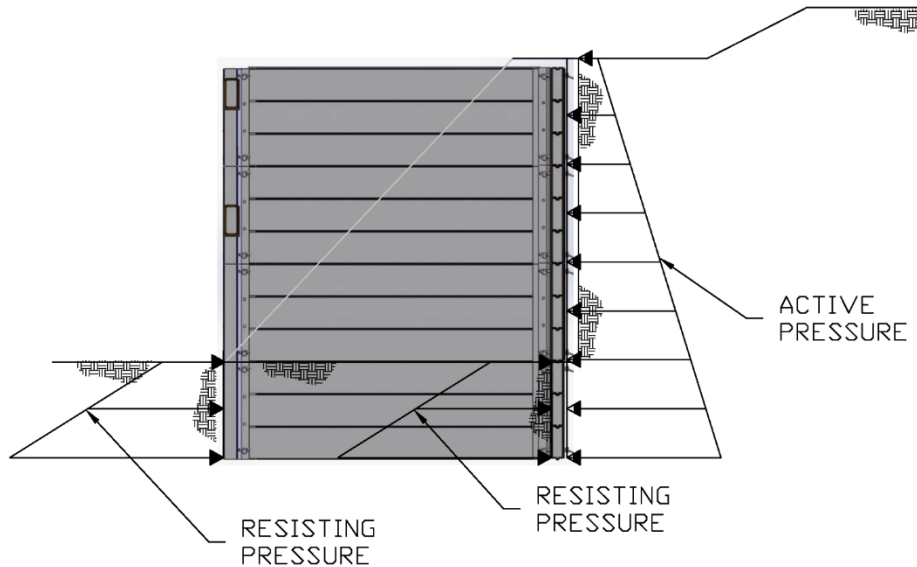

Figure 4-Active Soil +Rail Pressure and Resisting Pressure

This solution does require engineering calculations but here are the general principals behind the calculations. The pressure that soil exerts on shoring equipment walls when it is theoretically allowed to move or collapse onto it is called active soil pressure. When a shoring wall element, steel plate or sheet pile is pushed against the soil the soil develops a resisting force until the force gets high enough to cause it to move and fail to resist. In geotechnical terms this resisting force is called passive pressure. Based on Rankine theory with level backfill the soil pressure can be calculated by a simple formula;

For active pressure $P_a = k_a \gamma h$

For passive pressure $P_p = k_p \gamma h$

Where γ = unit weight of soil, (most varies between 115 psf to 125 psf)

The k values can be found in **Table 1**.

h =depth of excavation

The point here is not to do calculations but to understand what is going on. Table 1 has a line, K_p/K_a , this shows that depending on the density of the soil the resisting pressure that can be obtained by driving something down or burying to some depth the front side of a 3 -sided box is 4 to 20 times more than the active pressure that is placed on the back of the box, or conversely if the depth of shoring is 8 ft then it would need to be buried 1/4 to 1/20 that depth to keep it from sliding away. All that is needed is to develop enough resisting soil pressure at the open side of the box as there is on the back side of the box



where the soil is to the top of the box and sloping up from there. Keep in mind that the loaded side of the wall is also seeing loading from the sloped soil and surcharge loads.

The same principals can be applied to cohesive soils and even OSHA soil types. Table 2 gives approximate active and reactive pressures for OSHA Soil Types

| TABLE 1-Rankine Earth Pressure Coefficients For Level Backfill ^{Note 1} | | | | | | | | | |
|--|---|-------------------|-----------------|-------------------|-----------------|-------------------|-----------------|-------------------|-----------------|
| ϕ | 20 ^o | 22.5 ^o | 25 ^o | 27.5 ^o | 30 ^o | 32.5 ^o | 35 ^o | 37.5 ^o | 40 ^o |
| K_a | 0.49 | 0.45 | 0.41 | 0.37 | 0.33 | 0.30 | 0.27 | 0.24 | 0.22 |
| K_p | 2.04 | 2.24 | 2.46 | 2.72 | 3.00 | 3.32 | 3.69 | 4.11 | 4.60 |
| K_p/K_a | 4.16 | 4.98 | 6.00 | 7.35 | 9.09 | 11.07 | 13.67 | 17.13 | 20.91 |
| ϕ | = angle of internal friction for non-cohesive soil | | | | | | | | |
| K_a | = coefficient of active soil pressure (applied when the soil moves) | | | | | | | | |
| K_p | = coefficient of passive pressure, (applied when the soil is pushed on) | | | | | | | | |
| K_p/K_a | = ratio of active to passive pressure | | | | | | | | |
| Note 1-This table only applies to non-cohesive soils, (sands and gravels with less than 50% cohesive soils mixed in) | | | | | | | | | |

Another problem that develops when the boxes are buried to achieve resisting pressure is that the resisting forces are concentrated on a smaller wall area resulting in exceeding the allowable wall pressure of the shield. This can be solved by placing additional shield panels, sheet piles or plates in the buried area.

The shield shown in Figure 5 has no real front and back elements to burry so plate or sheet piles are driven in front of the shield ends. These types of installations require design by a registered engineer.

| TABLE 2-Approximate Active and Passive Soil Pressures for OSHA Soil Types | | | | |
|--|--------------------------|------------------------------------|--------------------------|---------------------------|
| OSHA Soil Type | Cohesive | | Non-Cohesive | |
| | Active ^{Note 1} | Passive ^{Note 2} | Active ^{Note 1} | Passive ^{Note 1} |
| | psf | psf (rectangular after first foot) | psf | psf |
| A | 25 h | 2000 | NA* ^{Note 3} | NA* ^{Note 3} |
| B | 45 h | 1000 | 45 h | 500 h _{passive} |
| C-60 | 60 h | 500 | 60 h | 350 h _{passive} |
| C-80 | 80 h | 0 | 80 h | 150 h _{passive} |
| Notes | | | | |
| 1 h = depth from surface for active pressure | | | | |
| h _{passive} = depth from surface of cut or bottom of excavation | | | | |
| 2 Use a rectangular load diagram starting at 1 ft below bottom of excavation | | | | |
| 3 OSHA Type A soil can only be cohesive | | | | |

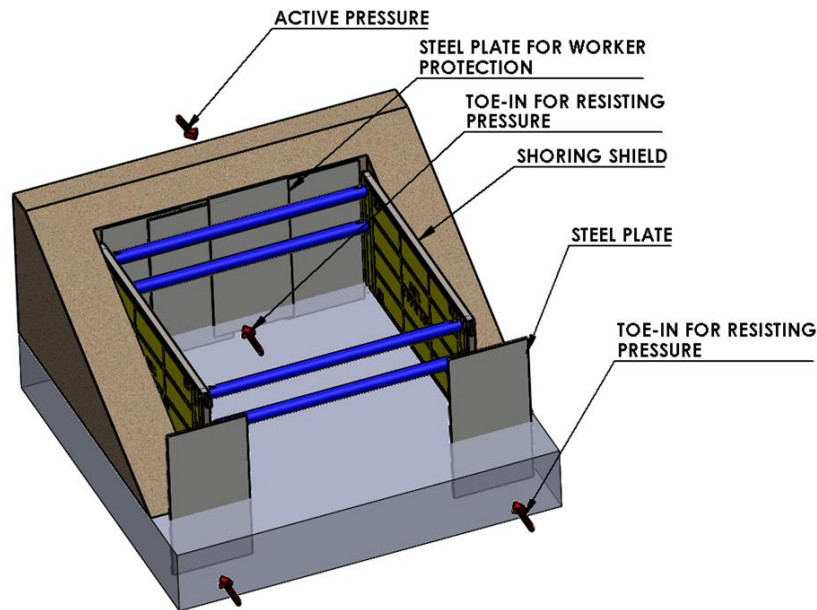

Figure 5-Shield with Steel Plate Resisting Elements

Other 3-Sided Excavation Issues

There are some situations that the competent person should be aware of when they are excavating around manholes and buried structures. Excavating in front of and below the base slab of these structures turns them into 3 sided shored excavations. The structure shores the ground surrounding the structure and the only thing the structure has to resist the active soil pressure is soil friction at the bottom of the slab and at the side walls. This is usually enough to prevent sliding except when the structure is founded in soft clays (type C-60 or worse), deep (over 16 ft deep it should be checked by an engineer) or there is water backed up behind the structure wall. Any one of these conditions should signal the competent person to get it checked out.

With deep structures there is a possibility of the structure being tipped over into the excavation. Stacked shoring shields must be connected so they can only move together and manhole sections can separate or shear at the joints.

When excavating below the bottom of a structure foundation the bearing soil is more likely to slide out.

All of these situations call for engineering evaluation and judgement.



Conclusion

The major reason for developing this article was to develop some concepts for a competent person to understand when that person is faced with a 3-sided shoring situation and for the project estimator to get enough money in the bid to pay for the extra work that goes into the shoring installation.

Other points are:

1. 3-sided shoring installations are complicated and not covered in tabulated data for the shoring equipment being used. Site specific engineering should be used.
2. Surcharge loading for shields applies to loading opposite the walls not at the open end of the shields
3. 3-sided shoring installations must be blocked at the open side so that they will not slide. This can be accomplished by several different methods or a combination of these methods:
 - partially bury the bottom of the box
 - drive plates or sheet piles in front of the box
 - backfill the sides to achieve friction on the walls
4. The tables and charts shown here are for reference only. They provide ball park estimates and can provide a sense of how much work, (cost), will be added to the cost of the shoring.
5. Excavating across the front of a buried structure or manhole turns it into a 3-sided shoring situation and should be checked by an engineer before excavating.
6. Regardless of the manufacturer of the equipment, shoring shield tabulated data does not usually address 3-sided loading, always an engineer should be consulted.