

# **NENA Review of Non-Traditional Communications to E9-1-1 PSAP Equipment**

**(ARCHIVED 20150922 FOR HISTORICAL PURPOSES)**

NENA Technical Information Document  
Non-Traditional Communications for E9-1-1  
NENA 07-502, Issue 1, March 20, 2001

Prepared by:  
National Emergency Number Association (NENA) Non-Traditional Technical Committee

Published by NENA  
Printed in USA

**(ARCHIVED 20150922 FOR HISTORICAL PURPOSES)**

**NENA TECHNICAL INFORMATION DOCUMENT**

NOTICE

This Technical Information Document is published by National Emergency Number Association (**NENA**) as a guide and recommendation for the delivery of non-traditional communications to customer-premise systems and 9-1-1 network elements that are used for the purpose of processing emergency calls at a PSAP. It is not intended to provide complete specifications or parameters nor to assure the acceptance of such signals at any PSAP.

**NENA** reserves the right to revise this Technical Information Document for any reason including, but not limited to, conformity with criteria or standards promulgated by various agencies, utilization of advances in the state of the technical arts or to reflect changes in the design of purpose, equipment or services described therein.

This document has been prepared solely for the voluntary use of E9-1-1 service providers, E9-1-1 equipment vendors, participating telecommunications companies and, local PSAPs.

By using this document, the user agrees that the **NENA** will have no liability for any consequential, incidental, special, or punitive damage that may result.

This document has been developed by the **NENA** Non-Traditional Communications Committee. Comments and/or recommendations for change to this document may be submitted to:

National Emergency Number Association  
1700 Diagonal Rd, Suite 500  
Alexandria, VA 22314  
202.466.4911  
or [commleadership@nena.org](mailto:commleadership@nena.org)

Acknowledgments:

The following industry experts and their companies are recognized for their contributions in development of this document.

**Acknowledgements**

**Chair: Tony Busam**

**Co-Chair: Bob Tilden**

Bernard Brabant

Nancy Pollack

William Gamblin

Joe Sallak

Rich Frye

Jeff Crollick

Barbara Thornburg

Sanford C Curcie

Dwight Purtle

Beverly Slocum

Kevin Sou

Cindy Clugy

David Jones

Marty Bausano

Marlys Davis

John Lathrop

Robert Russo

Timothy Dunn

Timothy Humrich

John Parrott

Ken Thacker

Pacific Bell

Bell Canada

Metropolitan 9-1-1, St Paul, MN

Mc Lean County II, 9-1-1

Motorola

Orbacom Systems, Inc.

SCC Communications

Winstar

Sytex Inc

Johnson County Kansas Communications

Positron

CML Emergency Services, Inc.

SCC Communications

Spartanburg County OES

Emergency Telephone System Board

King County 9-1-1

IEEE-1512 Representative

Pacific Bell

SignalSoft

Qwest

SCC

Alaska Communications Systems

<b>NENA REVIEW</b>	<b>1</b>
<b>1 INTRODUCTION</b>	<b>6</b>
1.1 GENERAL	6
1.2 PURPOSE AND SCOPE OF DOCUMENT	6
1.3 ORGANIZATION OF DOCUMENT	6
1.4 REASON FOR ISSUE	6
<b>2 DESCRIPTION OF NON-TRADITIONAL SOURCES OF SIGNALING WITHIN ENHANCED 9-1-1</b>	<b>7</b>
2.1 GENERAL	7
2.2 SOURCES OF NON-TRADITIONAL COMMUNICATIONS	8
<b>3 BARRIERS TO ADVANCING NON-TRADITIONAL COMMUNICATIONS THROUGH THE NETWORK</b>	<b>8</b>
<b>4 BARRIERS TO ACCEPTING NON-TRADITIONAL COMMUNICATIONS AT THE PSAP</b>	<b>9</b>
4.1 NETWORK INTERFACE	9
4.2 PREMISES EQUIPMENT	9
4.3 ALI NODE INTERFACES	9
4.4 OPERATIONAL ISSUES	9
<b>5 DISCUSSION SPECIFIC TO NON-TRADITIONAL SOURCES</b>	<b>10</b>
5.1 INTERNET VOICE	10
5.2 VOICE OVER IP (VOIP)	10
5.3 INTELLIGENT TRANSPORTATION SYSTEM	12
5.3.1 <i>Definition</i>	12
5.3.1.1 Automatic Collision Notification	12
5.3.1.2 ACN CALL DELIVERY USING CAS WIRELESS 9-1-1 TECHNOLOGY	14
5.3.1.3 ACN CALL DELIVERY USING NCAS WIRELESS 9-1-1 TECHNOLOGY	15
5.3.1.4 ACN – DATA ONLY NOTIFICATION TO NETWORK	16
5.4 CONCIERGE SERVICES	17
5.4.1 <i>Automatic Collision Notification (ACN) Call Delivery Processes</i>	18
5.4.1.1 THIRD PARTY CALL DELIVERY USING PSTN AND WIRELESS 9-1-1 TECHNOLOGY	18
5.5 MAYDAY DEVICES	19
5.6 MEDICAL HELP DESKS	19
5.7 CRIMINAL TRACKING	19
5.8 ALTERNATIVE OPERATOR SERVICES	20
5.9 SMART CLOTHES	20
<b>6 EXAMPLES OF NON-TRADITIONAL COMMUNICATIONS: METHODS AND TECHNOLOGIES</b>	<b>21</b>
6.1 INTERNET USING INTERNET SERVICE PROVIDER	21
6.1.1 <i>Internet Protocol-4 discussion</i>	23
6.1.2 <i>IP-4 and Location</i>	23
6.1.3 <i>Internet Protocol references available to NENA:</i>	24
6.1.3.1 DNS Resource Records [RFC1035]	24
6.1.3.2 Referral Whois Protocol [RFC2167]	24
6.1.3.3 URL Uniform Resource Location using DNS [RFC2168]	24
6.1.3.4 Dynamic Updates in the Domain Name System [RFC2136]	24
6.1.3.5 DNS extensions to Network Address Translators [ RFC2694]	24

**(ARCHIVED 20150922 FOR HISTORICAL PURPOSES)**

6.1.3.6	Minimal PSTN address format in Internet Mail [RFC2303]	24
6.1.3.7	Minimal FAX address format in Internet Mail [RFC2304]	25
6.1.3.8	Toward the PSTN/Internet Inter-Networking [RFC2458]	25
6.1.4	<i>Starting Points for IP location strategies</i>	25
6.1.4.1	IETF - Internet Engineering Task Force (IETF) < <a href="http://www.ietf.org">www.ietf.org</a> >	25
6.1.4.2	IANA - Internet Assigned Numbers Authority < <a href="http://www.iana.org">www.iana.org</a> >	25
6.1.4.3	ICANN - Internet Corporation for Assigned Names and Numbers < <a href="http://www.icann.org">www.icann.org</a> >	25
6.2	CONCIERGE CALL DELIVERY (CURRENT - 2000)	26
6.2.1	<i>Discussion: Concierge Call Delivery (current-2000)</i>	26
6.3	LOCALIZED SPATIAL ROUTING CONCEPT	27
6.3.1	<i>Discussion: Localized Spatial Routing Concept</i>	27
6.4	NON-LOCALIZED SPATIAL ROUTING CONCEPT	28
6.4.1	<i>Discussion: Non-Localized Spatial Routing Concept</i>	28
7	<b>GLOSSARY (<a href="http://www.nena.org/?page=glossary">HTTP://WWW.NENA.ORG/?PAGE=GLOSSARY</a>)</b>	<b>29</b>

Archived

## **1 Introduction**

The emergence of telecommunication systems capable of alerting emergency services to incidents from instruments other than a traditional telephone or wireless telephone requires convergence to successfully integrate with 9-1-1. This document is intended to identify these technologies, their challenges and potential solutions or alternatives to the public safety community.

The existence of this document does not support, promote nor defend any particular technology. Its sole purpose is to inform and offer solutions to the problem of integration to those wishing to either offer or accept such forms of communication.

### **1.1 General**

A PSAP is an agency or group of agencies designated and authorized to receive and respond to emergency calls requiring one or more public services (Police, Fire, EMS or all three).

### **1.2 Purpose and Scope of Document**

This document will identify, define, discuss and offer potential solutions or alternatives to interfaces required to bring non-traditional sources of information into Enhanced 9-1-1 Public Safety Answering Point (PSAP).

### **1.3 Organization of Document**

Section 1	Introduction
Section 2	Description of the Sources of Non-Traditional Communications within Enhanced 9-1-1
Section 3	Barriers to Advancing Non-Traditional Communications Through the Network
Section 4	Barriers to Accepting Non-Traditional Communications at the PSAP
Section 5	Discussion Specific to Non-Traditional Sources
Section 6	Examples of Non-Traditional Communications Methods and Technologies
Section 7	Glossary of Terms

### **1.4 Reason for Issue**

Telecommunications advances allow entry into emergency services by means other than those considered "traditional". In the context of this document, "traditional" may be assumed to refer to a seven-digit telephone number or either form of 9-1-1 services (Basic or Enhanced).

**(ARCHIVED 20150922 FOR HISTORICAL PURPOSES)**

Document Number	Approval Date	Reason For Changes
NENA 07-502	03/20/2001	Initial Document
NENA 07-502 v1.1	05/25/2015	Update web page links

## **2 Description of Non-Traditional Sources of Signaling within Enhanced 9-1-1**

### **2.1 General**

Traditional 9-1-1 signaling has been exclusively a calling party initiated event, i.e.: dialing 9-1-1 from a telephone. In the context of this document, signaling is intended to be related to the transmission of both voice and data. The introduction of such signaling should be conducted in such a manner that it does not interfere with the existing functions of a 9-1-1 system. As used within the context of this document non-traditional signaling is intended to be sources of incident notification other than those explained above and within the body of other NENA documents.

From the point of initiation non-traditional signaling takes two basic (e.g. "active" and "passive") forms. Active signaling may best be described as that which is initiated by a reporting party. Active signaling may or may not include voice contact with the reporting party. By definition active signaling requires the reporting party to perform some action that advances the call for assistance to any networks involved and to the call taking station of a PSAP.

Passive signaling may best be described as that which is initiated in an automated fashion. Passive signaling may or may not include voice contact with the reporting party. When initiated passive signaling advances the call for assistance to any networks involved and to the call taking position of a PSAP.

Another form of non-traditional signaling would be introduction of voice notification from sources outside of the normal PSTN (Public Switched Telephone Network). An example of this non-traditional signaling would be the transmission of voice over a packet network (VoIP over ATM, Frame Relay backbone or Voice over DSL (VoDSL)).

Some traditional PSTN resources are bypassed when using IP. Location identification is the problem with this mode of operation. Under current implementation, the 9-1-1 PSAP reached when dialing 9-1-1 is that of the POP (Point Of Presence) into the PSTN for the IP voice carrier. This poses a great problem for location identification.

Because of the unique and very specific needs of each of these non-traditional sources of signaling, standards for interfaces are required. Whether or not local government chooses to accept such signaling, its introduction cannot interfere with the day-to-day operations of a PSAP.

**(ARCHIVED 20150922 FOR HISTORICAL PURPOSES)**

## 2.2 Sources of non-traditional communications

Specific examples of non-traditional communications may include:

- Internet Voice
- Internet email / chat
- Intelligent Transportation System
- Concierge Services
- Mayday Devices
- Medical Help Desks
- Criminal Tracking
- Voice over packet
- Smart Clothes

## 3 Barriers to Advancing Non-Traditional Communications through the Network

Call signaling, processing and movement through the Public Switched Telephone Network of calls to 9-1-1 is largely based on point-to-point signaling. Advances in technologies can be the means by which the public gains access to emergency services and this may lead to some new definitions for these processes.

The body of work being done in preparation for Phase 2 of the FCC wireless mandate addresses some of the issues that may be common to non-traditional signaling. As work on this initiative continues emerging technology is placing additional demands upon the 9-1-1 infrastructure and additionally on the public safety community.

Third party notification of an incident may have the effect of delaying the notification process and delays the appropriate response. Not only does third party notification present a time delay-it presents informational relay issues as well. Since 9-1-1 has traditionally been a closed point to point communication of voice and data elements the interjection of a third party processing requires methods to "pass along" these voice and data elements to the termination point.

The increasing public mobility and reliance on wireless devices will usher in more and more of the third party intermediary services. The challenge and goal is to effectively integrate these services into the 9-1-1 infrastructure while retaining the unique features of 9-1-1 services.

Traditional 9-1-1 network components such as Selective Routers and Database Management hardware/software platforms may require new standards to accommodate these non-traditional 9-1-1 voice and data elements.



**(ARCHIVED 20150922 FOR HISTORICAL PURPOSES)**

## **4 Barriers to Accepting Non-Traditional Communications at the PSAP**

### **4.1 Network Interface**

An assortment of problems emerges when non-traditional communications are received at a PSAP. Common equipment may not recognize the receipt of a call especially where signaling on non-traditional 9-1-1 communications is involved. Likewise, the information received in data format may not be meaningful to the local PSAP call taker.

### **4.2 Premises Equipment**

Non-traditional 9-1-1 calls can be represented by "data only" packets from systems like Intelligent Transportation Systems. Also, third party call centers may wish to relay informational data packets along with the relay of voice communications. This can pose barriers to the existing CPE at the PSAP.

Currently the primary method of delivery of data packets to the PSAP is via the traditional ALI node links. Ideally these packets should be presented to the PSAP using this existing infrastructure. However, this will likely require some development or revision of protocols used to formulate ALI bid requests from the CPE to the ALI node. It shall be desirable to have a standardized data format fashioned after approved ALI formats that are delivered to the call taking position upon notification of an incident. NENA ALI format version 4 utilizing XML tag data should be considered as a universal standard.

### **4.3 ALI node Interfaces**

Utilizing existing pooled ALI node infrastructure to serve as a repository for data packets originating from non-traditional 9-1-1 sources shall require development of dynamic ALI interfaces. . Non-traditional 9-1-1 data will be generated in real-time since the information is dynamic and depends on the incident that initiates the 9-1-1 call. Also, the ALI node must be able to interpret the revised ALI requests from the PSAP CPE as outlined above.

### **4.4 Operational Issues**

In the case of passive non-traditional communications systems local government may resist the introduction of this signaling within the context of the PSAP. This resistance may result in the proliferation of third party call centers that will act as national clearinghouses for these types of devices. This resistance can be addressed with formulation of local practices and procedures dealing with the handling of these type calls. Also, the possible increases in call volume and procedures required to process the data would likely necessitate a review of staffing resources at the PSAP level.

**(ARCHIVED 20150922 FOR HISTORICAL PURPOSES)**

## **5 Discussion Specific to Non-traditional Sources**

### **5.1 Internet Voice**

VoIP is an organized effort to standardize IP telephony. IP telephony is an important part of the convergence of computers, telephones, and television into a single integrated information environment. Also see another general term, computer-telephony integration (CTI), which describes technologies for using computers to manage telephone calls. Voice over Packet (VoP) depicts a set of new emerging voice handling technologies. Voice over IP (VoIP) is a term used in IP telephony for a set of facilities for managing the delivery of voice information using the Internet Protocol (IP). The voice information is transmitted in digital form in discrete packets rather than in the traditional circuit committed protocols of the Public Switched Telephone Network (PSTN).

VoIP, now used somewhat generally, derives from the VoIP Forum, an effort by major equipment providers, including Cisco, VocalTec, 3Com, and Netspeak to promote the use of ITU-T H.323, the standard for sending voice (audio) and video using IP on the public Internet and within intranets. The Forum also promotes the user of directory service standards so that users can locate other users and the use of touch-tone signals for automatic call distribution and voice mail.

In addition to IP, VoIP uses the real-time protocol (RTP) to help ensure that packets get delivered in a timely way. Using public networks, it is currently difficult to guarantee Quality of Service (QoS). Better service is possible with private networks managed by an enterprise or by an Internet telephony service provider (ITSP).

### **5.2 Voice over IP (VoIP)**

IP telephony (Internet Protocol telephony) is a general term for the technologies that use the Internet Protocol's packet-switched connections to exchange voice, fax, and other forms of information that have traditionally been carried over the dedicated circuit-switched connections of the Public Switched Telephone Network (PSTN).

Using the Internet calls travel as packets of data on shared lines avoiding the tolls of the PSTN. The challenge in IP telephony is to deliver the voice, fax, or video packets in a dependable flow to the user. Much of IP telephony focuses on that challenge.

IP telephony service providers include or soon will include local telephone companies, long distance providers such as AT&T, cable TV companies, Internet service providers (ISPs), and fixed service wireless operators. IP telephony services also affect customer premise equipment (CPE) vendors of traditional hand-held devices.

Currently, unlike traditional phone service, IP telephony service is relatively unregulated by government. In the United States the Federal Communications Commission (FCC) regulates phone-to-phone connections however indicates that they do not plan to regulate connections between a PSTN and an IP telephony service provider.

**(ARCHIVED 20150922 FOR HISTORICAL PURPOSES)**

For instance, IP next generation (IPng) version 6 will be used over the following types of media:

- Ethernet Networks
- Fiber Distributed-Data Interface (FDDI) Networks
- Token Ring Networks
- IPv4 Domains without Explicit Tunnels
- ARCnet Networks
- Point-to-Point Protocol (PPP)
- Non-Broadcast Multiple Access (NBMA) networks
- Asynchronous Transfer Mode (ATM) Networks
- Point-to-Point ATM Link
- Institute of Electrical and Electronic Engineers (IEEE) 1394 Networks
- Frame Relay Networks

A concern for 9-1-1 communications is to guarantee an end to end Quality of Service (QoS) for the caller and the call taker.

VoIP could be used with private networks managed by an enterprise, an Internet Telephony Service Provider (ITSP), or with public networks managed by a Cable company, a Wireless Service Provider (WSP), etc.

VoIP interconnection to the Public Switched Telephone Network (PSTN), therefore to the 9-1-1 networks, is allowed by using a gateway. That gateway receives voice transmissions by way of packets (a packet consists of a logical grouping of data representing a portion of the digitized voice transmission) from users within the IP network and routes them to the PSTN network using a trunk interface.

With the advent of VoIP, internetworking technology will support a common protocol that can work over a variety of physical networks. For example, devices when disconnected will use RF wireless networks; when used in networked facilities will use infrared attachment; and when docked/plugged will use physical wires.

VoIP will be required to support large scale routing and addressing. It will require a protocol which imposes a low overhead and supports auto configuration and mobility as basic elements. These may require having to enhance the 9-1-1 network entities' capability to support interoperability and interconnectivity.

Further, call routing and callback will need to deal with powerful new IP routing capabilities such as "Provider Selection", "Host Mobility" (route to current location) and "Auto-Readdressing" (route to new address).

Other 9-1-1 functionalities that would also need to be ensured are:

- "Call Priority" to enable a source to identify the desired delivery priority of the 9-1-1 voice packets,
- "Security" (confidentiality of voice communication/data content).

**(ARCHIVED 20150922 FOR HISTORICAL PURPOSES)**

- "Location Identification" (potentially using Dynamic Location Information using data exchange)

## **5.3 Intelligent Transportation System**

### **5.3.1 Definition**

The Intelligent Transportation System (ITS) Deployment Program was established by federal regulation. It contains two components- the Intelligent Transportation System Integration Program and the Commercial Vehicle Intelligent Transportation Infrastructure Deployment Program.

Under the general business operations two offices have direct responsibility for emergency services within the United States: Office of Transportation Operations and Office of Travel Management. Of particular interest to Public Safety is a mandate for the integration of emergency preparedness and incident management.

Within this broad coalition are two standards setting bodies: the Institute of Electrical and Electronics Engineers (IEEE) and the Society of Automotive Engineers (SAE). The IEEE generally is responsible for signaling parameters while the SAE is responsible for the functions within an intelligent vehicle and how they are monitored.

Additionally, ITS is developing technologies that may be of interest to public safety. Weather response operations, traffic control technologies, capacity measurement and monitoring, and travel information may be of some use at the PSAP level. Of particular note is the Automatic Collision Notification (ACN) systems envisioned for placement in future automobile models.

Data originating from vehicle-based notification systems need to be standardized. Current efforts by government and standardization bodies may offer the appropriate data definition required and facilitate compatibility with delivery of the information to a 9-1-1 PSAP. This needs to address the interface from the reporting party to the telecommunications network, and from the telecommunications network to the PSAP. Efforts to use existing protocols are encouraged. A list of the organizations involved in the delivery of data from the vehicle to third parties needs to be established so as to assist in identifying roles and responsibilities.

#### **5.3.1.1 Automatic Collision Notification**

Automatic collision notification uses sensors within the vehicle to recognize that a significant event has occurred. Through the use of accelerometers, air bag deployment sensors and crumple zone alerting devices, onboard computers estimate the severity of the incident. As envisioned, a message set regarding the number of occupants, severity codes, and vehicle location could be assembled into a data format. This data could then be advanced through a 9-1-1 infrastructure to the appropriate PSAP based on the vehicle location.

Whether or not the data would be accompanied by a voice message may be affected by several parameters including the condition of the occupants; the orientation of antennas; and condition of the transmission equipment after a collision. Similarly, the delivery of data regarding collision

**(ARCHIVED 20150922 FOR HISTORICAL PURPOSES)**

notification information would be affected by the antennas and equipment condition of the involved vehicle.

Archived

**(ARCHIVED 20150922 FOR HISTORICAL PURPOSES)**

Automatic Collision Notification (ACN) Call Delivery Processes

**5.3.1.2 ACN CALL DELIVERY USING CAS WIRELESS 9-1-1 TECHNOLOGY**

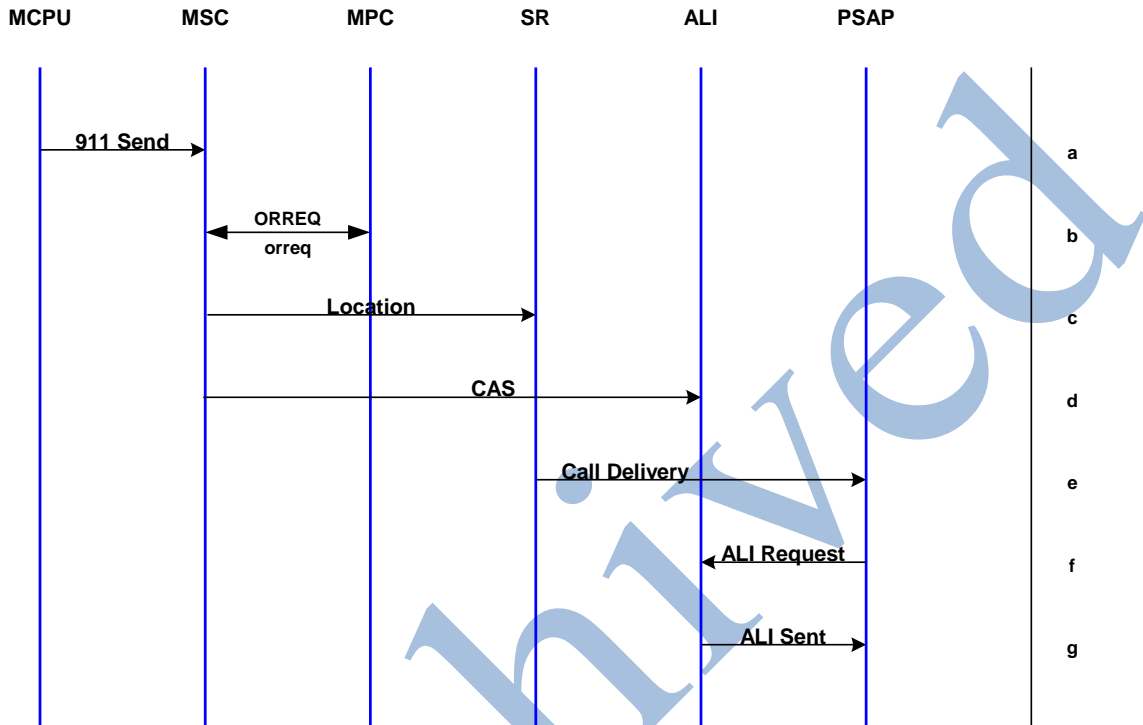

- a) Automotive Master CPU issues 9-1-1 digit order to mobile device issuing "SEND". Mobile Switch Center recognizes 9-1-1 digits and advances order to a Wireless System Control Point.
- b) Mobile Switch Center forwards call to Wireless Mobile Positioning Center, which reports location.
- c) Wireless Mobile Positioning Center orders ESN based on polygon from a Coordinate Routing Database.
- d) Wireless Mobile Switch Center issues CAS based update to ALI
- e) Selective Router advances call setup to appropriate PSAP CPE based upon associated signaling.
- f) PSAP CPE requests ALI
- g) ALI system returns NENA v.3 data-gram of ALI for associated call.

*Reference:* TR-45 TIA/EIA/IS-J-STD-036

**(ARCHIVED 20150922 FOR HISTORICAL PURPOSES)**

**5.3.1.3 ACN CALL DELIVERY USING NCAS WIRELESS 9-1-1 TECHNOLOGY**

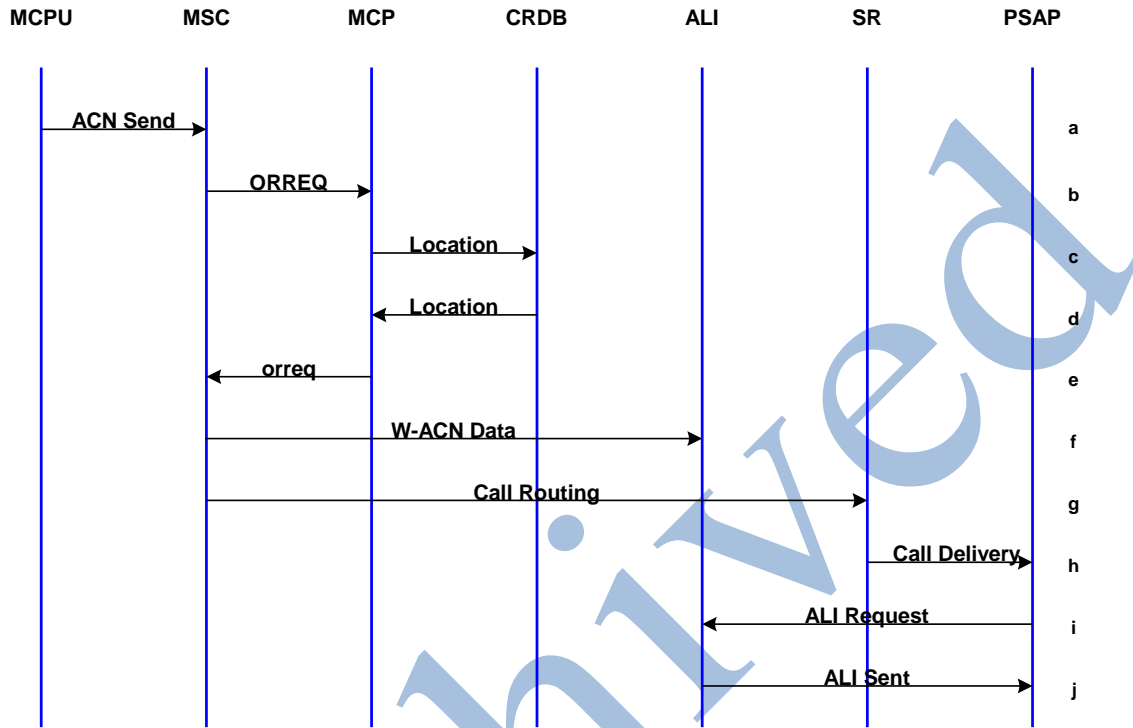

- a) Automotive Master CPU issues 9-1-1 digit order to mobile device issuing "SEND". Parallel process initiates location technology systems as an expression of latitude, longitude and precision of accuracy (does not use onboard location).
- b) Mobile Switch Center recognizes 9-1-1 digits and advances order to a Wireless Mobile Positioning Center.
- c) Wireless Mobile Positioning Center requests location for ACN sending unit from the Coordinate Routing Database.
- d) The Coordinate Routing Database returns x,y,(z) to Wireless Mobile Positioning Center.
- e) Wireless Mobile Positioning Center orders ESN based on polygon containing reported location. Call completes setup.
- f) Wireless 9-1-1 Mobile Switch Center sends 9-1-1 call associated data to ALI system.
- g) Mobile Switch Center sends call with associated signaling to Selective Router
- h) Selective Router advances call setup to appropriate PSAP CPE based upon associated signaling.
- i) PSAP CPE requests ALI
- j) ALI system returns NENA v.3 data-gram of ALI for associated call.

*Reference:* TR-45 TIA/EIA/IS-J-STD-036

**(ARCHIVED 20150922 FOR HISTORICAL PURPOSES)**

### 5.3.1.4 ACN – DATA ONLY NOTIFICATION TO NETWORK

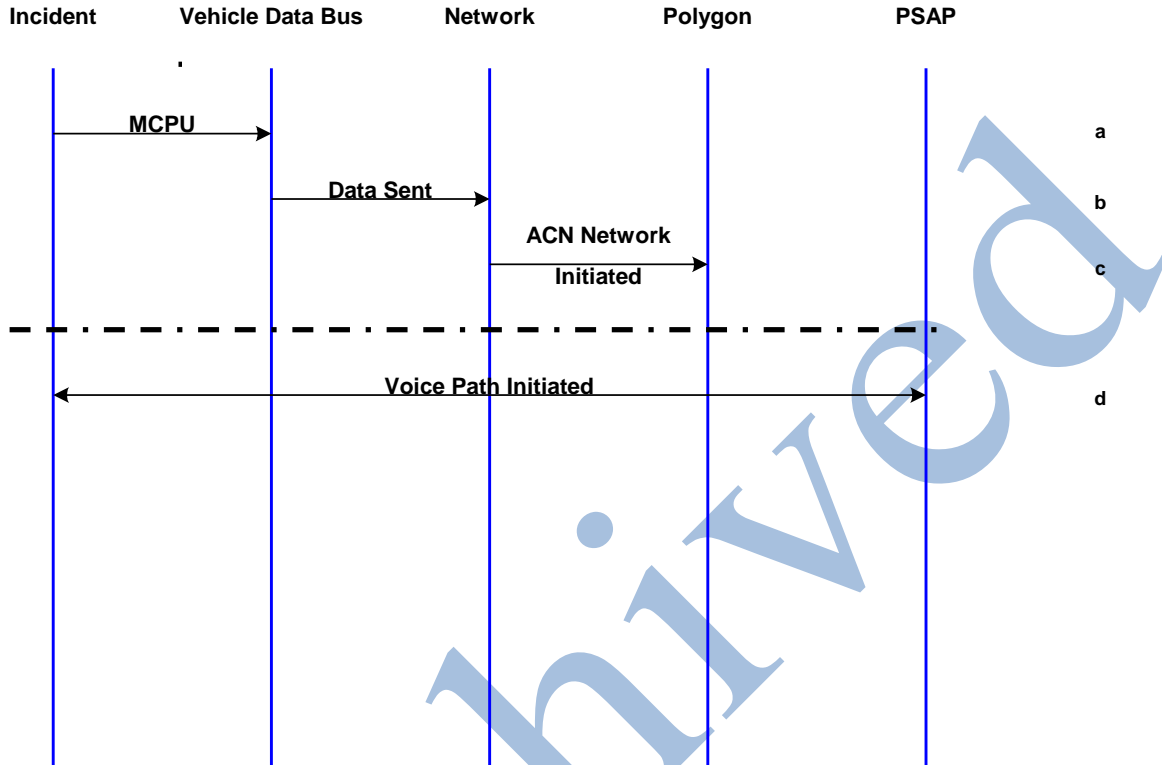

- A) MCPU initiates collision notification via RF
- B) Collision data is sent to RF control point
- C) Control point routes data call to PSAP
- D) If cellular technology, possible voice path via network to occupants

*Reference: TR-45 TIA/EIA/IS-J-STD-036*



#### 5.4 Concierge Services

Concierge services are proliferating within the automobile industry. Primarily intended for traveler information, these Call Centers are occasionally contacted regarding vehicle accidents, acute medical circumstances and law enforcement issues. Some of the more sophisticated services receive location information of the calling party in the form of latitude and longitude. These services could forward voice calls for emergency assistance to the appropriate PSAP along with the associated data. However forwarding of these calls and associated data is not possible with today's current infrastructure.

An additional current barrier to a successful call is the inability to identify the appropriate PSAP. Usually based in a centralized location, call takers for these services do not generally have access to specific information regarding boundaries of individual emergency service providers. Interjecting the voice and caller's telephone number into the existing 9-1-1 infrastructure from a concierge service requires additional features and functionality on the part of the network and the concierge service CPE.

The concierge services should be provided with a registry of non-listed PSAP numbers so as to facilitate delivery of these calls until technical interfaces to the emergency network are developed. They should continue to be maintained in the event of call delivery failures even after interface standards have been developed.

**(ARCHIVED 20150922 FOR HISTORICAL PURPOSES)**

## 5.4.1 Automatic Collision Notification (ACN) Call Delivery Processes

### 5.4.1.1 THIRD PARTY CALL DELIVERY USING PSTN AND WIRELESS 9-1-1 TECHNOLOGY

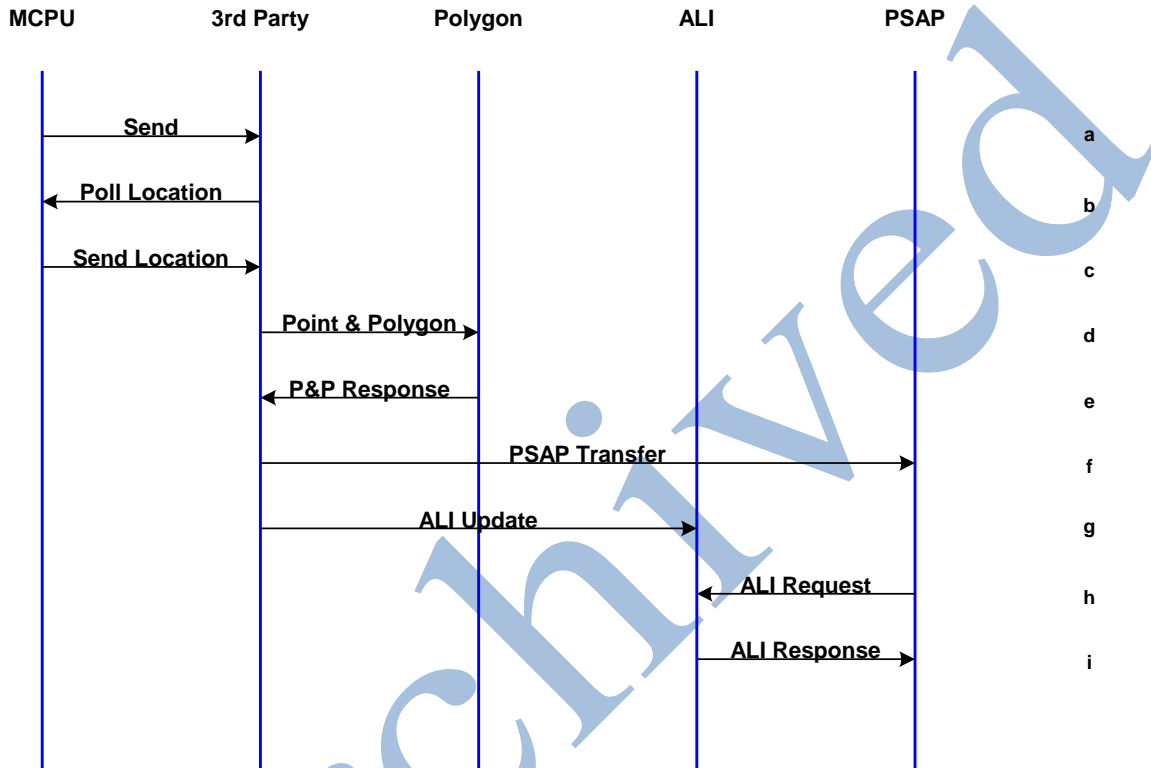

- a) Automotive Master CPU issues 3<sup>RD</sup> PARTY psap digit order to mobile device issuing "SEND". Connects as normal wireless call
- b) 3<sup>rd</sup> party PSAP polls MCPU for x,y location data
- c) MCPU issues location data over voice path
- d) 3<sup>rd</sup> party PSAP matches x,y point data within a polygon and derives PSAP routing instructions.
- e) Point & Polygon Response
- f) (non-existing) Voice is sent via PSTN to PSAP
- g) PSAP ALI data server populated with ACN data.
- h) PSAP requests ACN ALI data.
- i) ALI system returns NENA v.3 data-gram of ALI for associated call.

## **5.5 Mayday Devices**

Devices that are intended to activate an emergency response not otherwise defined within this document are generically known as Mayday devices. These devices may or may not require some form of action by persons requiring attention are categorized as Mayday systems and therefore can be either active or passive.

An active device requires the direct action of an individual to produce a signal. An example of such a device is the “officer in distress” mode contained within some public safety radio systems. A public safety officer depresses some switch on a radio device that enable special signaling intended for notification of the need for immediate assistance.

Passive devices are emerging as methods of tracking individuals. A prime example of this technology is generically referred to as “Child Find”. A device is either worn on the person or secreted within clothing allowing the tracking of the wearer. In its most extreme use, a child late from school could be found based on the x,y of the location of the medallion. Locating Alzheimer victims likewise could be automated with this function.

## **5.6 Medical Help Desks**

These call centers are concierge services tailored to the provisioning of health care services by medical insurers. Some medical insurers encourage and, in some cases, require their members to contact them before they seek medical treatment. The standard term for these services is nurse advice lines. Using medical protocols, the nurses determine if a patient needs to be seen immediately, the next day or whatever the insurers' protocols advocate. Naturally, a small number of calls are emergency cases. These callers are traditionally told to hang up and dial 9-1-1. Problems may arise when the caller loses consciousness or is unable to dial 9-1-1 for any reason. This service poses a unique issue in that in its standard operation the call center does not receive calling party telephone number or location and therefore has no relevant data to submit into the network. This is a voice only emergency call.

## **5.7 Criminal Tracking**

Law enforcement and the judicial system are continually seeking to reduce costs associated with confinement of convicted criminals. States and local governments are exploring methods of placing individuals under, what is best described as, “modified house arrest”. Under these conditions individuals are allowed to exist outside of the normal jail setting sometimes living at home. Devices attached to these individuals allow tracking of their movements and identification of any variance from an approved plan. Should an individual move into a restricted space or attempt contact with a prohibited party, alarm notification may take place in the form of either a site address or latitude/longitude. This information then needs forwarding to the appropriate call center.

**(ARCHIVED 20150922 FOR HISTORICAL PURPOSES)**

## **5.8 Alternative Operator Services**

With the increase in alternative local access services (ILEC, CLEC and ALEC) traditional operator services change. While most incumbent local exchange carriers (ILEC) have more experience in routing emergency calls dialed as “O” (Operator) based on information provided by their internal 9-1-1 support organization, alternative carriers do not have the same institutional or resource data available.

## **5.9 Smart Clothes**

As currently defined “Smart Clothing” will have sensors built into them monitoring the overall health of the wearer. Upon sensing some distress the wearer would be alerted to seek medical attention. The impact to 9-1-1 seems to be when the wearer is incapacitated and the clothing issues an alert as to condition, location and other patient information.

Archived

(ARCHIVED 20150922 FOR HISTORICAL PURPOSES)

## 6 Examples of Non-Traditional Communications: Methods and Technologies

### 6.1 Internet using Internet Service Provider

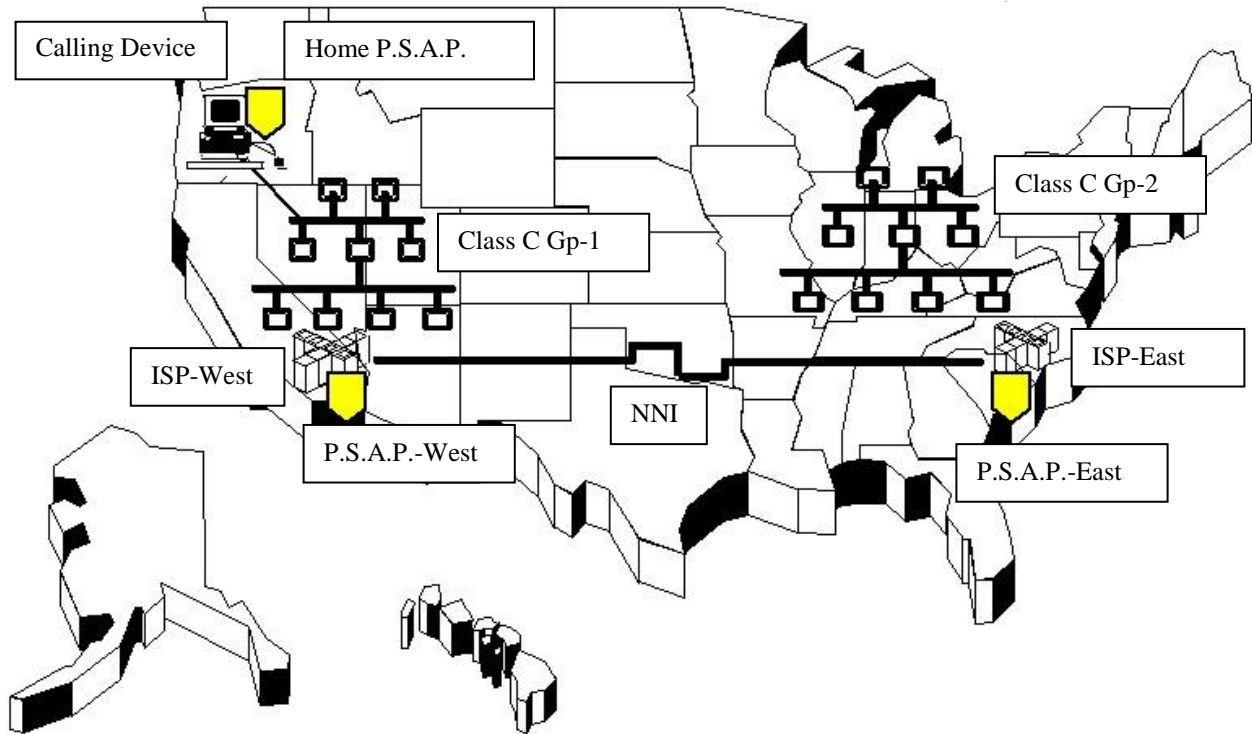

A large, national Internet Service Provider (ISP) may have one or many “points of presence” (PoP). In this diagram the ISP has two PoPs, one East and one West. It is at the PoP that dialtone may be drawn. In this scenario the caller (represented as the Calling Device) attempts access to 9-1-1 via VoIP. Dial tone could be drawn from either the East or West PoP and the probability of call completion would fall to the corresponding East/West P.S.A.P., not the Home P.S.A.P. Following is the call trace for this scenario as derived from actual internet interactions. Certain elements have been intentionally modified to prevent a perception of one ISPs configuration as flawed.

*Committee note: This depiction and trace is common across most ISPs at the time of authoring this section.*

**(ARCHIVED 20150922 FOR HISTORICAL PURPOSES)**

Step 1.

Using DNS to find the domain name for IP address [2X.5.74.XX]

nslookup 2X.5.74.XX

Name: proxyX.salem1.or.NNN.com  
Address: 2X.5.74.XX

Step 2.

Using WHOIS to find the administration of networks containing [2X.5.74.XX]

The query is against "whois.arin.net" the American Internet Registry.

[whois.arin.net]  
ISP (NETBLK-ISP) ISP 2X.0.0.0 – 2X.19.255.255  
ISP (NETBLK-OR-ISP-SALEM-2) OR-ISP2-SALEM-2 2X.5.74.X – 2X.5.74.XXX

To single out one record, look it up with "!xxx", where xxx is the handle, shown in parenthesis following the name, which comes first.

2.a.

Here we see that *ISP* is the bigger address block, and the smaller address block has been delegated to *OR-ISP2-SALEM-2*.

Step 3.

Using WHOIS to find the closest administrative authority, we query for *OR-ISP2-SALEM-2* against the "whois.arin.net" database.

[whois.arin.net]  
ISP (NETBLK-OR-ISP2-SALEM-2)  
Street Address  
Redwood City, State zipcode  
US

Netname: OR-ISP2-SALEM-2  
Netblock: 2X.5.74.X – 2X.5.74.XXX

Coordinator:

Operations, Network (*ISP-NOC-ARIN*) noc@NOC.ISP.NET  
1-800-NXX-3595 Fax- NPA-NXX-8501

March 20, 2001, Issue 1

Page 22 of 33

**(ARCHIVED 20150922 FOR HISTORICAL PURPOSES)**

Record last updated on 02-Dec-1998.

Database last updated on 21-Dec-1999 15:57:53 EDT.

[The following mnemonics were intentionally used to replace actual information ---  
X=Replacement of number/octet; *ISP*=Replacement of primary ISP; *ISP2*=Replacement of  
secondary ISP identifier; *NXX*=Replacement of telephony prefix; *NPA*=Replacement of  
telephony area code]

### **6.1.1 Internet Protocol-4 discussion**

It is important to understand the basics of internet addressing to allow further discussion regarding possible solutions to location enabling technologies. There are four (4) classes of prime numbers associated with the Internet Protocol-4 (IP4) scheme:

The basic address under IP4 is: O.O.O.O (where O represents a place holder for an octet).

Class-A: For use primarily for providers of the “backbone”, or, wide-band services. The first octet is based on XX (0-99).

Class-B: For use primarily by ISPs. The first octet is based on XXX (172-190).

Class-C: Used by the ISP to either dynamically assign a temporary IP address to a device (DHCP) or to permanently assign an address based upon the type of service being offered. The first octet is based on XXX (192-239).

Reserved: Networks not accessing the world-wide-web may use reserved octets for virtual private networks (VPN). Campus environments, and small-to-large networks are examples of the reserved usage. When workstations within a VPN access the world-wide-web, they are usually assigned Class-C status by the local server of DHCP device.

### **6.1.2 IP-4 and Location**

Resolving geographic positioning of IP addresses is a complex process. The fact that IP addresses are not globally unique precludes the ability to construct a consistent data query strategy.

Attempts to keep the Internet manageable without exhausting public IP addresses require implementing network address translation technologies and implementing private networks. The private networks reuse addresses in dedicated address spaces. A common address translation technology causes many private IP addresses to masquerade behind a single public IP address interface on a masquerade firewall or proxy server. This has the affect of preventing the assignment of a useful address to a particular Class-C IP within the current limitations of number exhaustion.

**(ARCHIVED 20150922 FOR HISTORICAL PURPOSES)**

### **6.1.3 Internet Protocol references available to NENA:**

A Request For Comment (RFC) document is the normal manner in which issues of internet protocols are disseminated. While many RFCs exist, certain ones are more useful for the process of determining a particular device than others. Following is a list of such RFCs that can be used to begin the process of assigning location to devices.

#### **6.1.3.1 DNS Resource Records [RFC1035]**

Name	Resource name (i.e. domain name)
Type	Resource Record Type (i.e. A, NS, MX, CNAME)
Class	Network Type (i.e. IN=Internet, CS=CSNET)
TTL	Time To Live in Seconds (32-bit)
Rlength	Length of resource record value
Rdata	This is the resource record value

#### **6.1.3.2 Referral Whois Protocol [RFC2167]**

The registry of public authorities for domains and networks is kept in a referral whois distributed database.

#### **6.1.3.3 URL Uniform Resource Location using DNS [RFC2168]**

This is used extensively in WWW web based applications.

#### **6.1.3.4 Dynamic Updates in the Domain Name System [RFC2136]**

Older DNS software systems do not provide for dynamic updates. Many of the newer DHCP servers are experimenting with dynamic DNS updates.

DHCP is the dynamic host configuration protocol and is used extensively for dynamic IP address assignments for dial-in and other network connections.

#### **6.1.3.5 DNS extensions to Network Address Translators [ RFC2694]**

Network Address Translators often reside on the border of public and private networks, hiding the addressing of the private networks.

This RFC describes some of the research being performed to coherently resolve name-to-address IP translation issues when network address translators are involved.

#### **6.1.3.6 Minimal PSTN address format in Internet Mail [RFC2303]**

This may relate to voice-mail delivered by internet text mail with mime-compliant voice



**(ARCHIVED 20150922 FOR HISTORICAL PURPOSES)**

#### **6.1.3.7 Minimal FAX address format in Internet Mail [RFC2304]**

A recommendation on encoding telephone fax addressing inside internet mail.

#### **6.1.3.8 Toward the PSTN/Internet Inter-Networking [RFC2458]**

This is an informational document that describes a variety of PSTN services and their various issues related to the Internet.

#### **6.1.4 Starting Points for IP location strategies**

To resolve geographic positioning for end-point IP for telephone services would possibly require a dynamic Domain Name Service (DNS) resource record strategy. The working groups most likely to accomplish these strategies are:

##### **6.1.4.1 IETF - Internet Engineering Task Force (IETF) <[www.ietf.org](http://www.ietf.org)>**

Internet protocol requirements must be reviewed and approved by the Internet Engineering Task Force. Their web page "<http://www.ietf.org>" contains the working group drafts before they are finalized as official RFCs and specifications.

##### **6.1.4.2 IANA - Internet Assigned Numbers Authority <[www.iana.org](http://www.iana.org)>**

The function of this organization is to maintain the registry of all assigned protocol related numbers, names, mnemonics, etc.

##### **6.1.4.3 ICANN - Internet Corporation for Assigned Names and Numbers <[www.icann.org](http://www.icann.org)>**

This organization is taking over many of the duties of IANA, including IP address space allocation, protocol parameter assignment, domain name system management, and root server system management functions.

**(ARCHIVED 20150922 FOR HISTORICAL PURPOSES)**

## 6.2 Concierge Call Delivery (current - 2000)

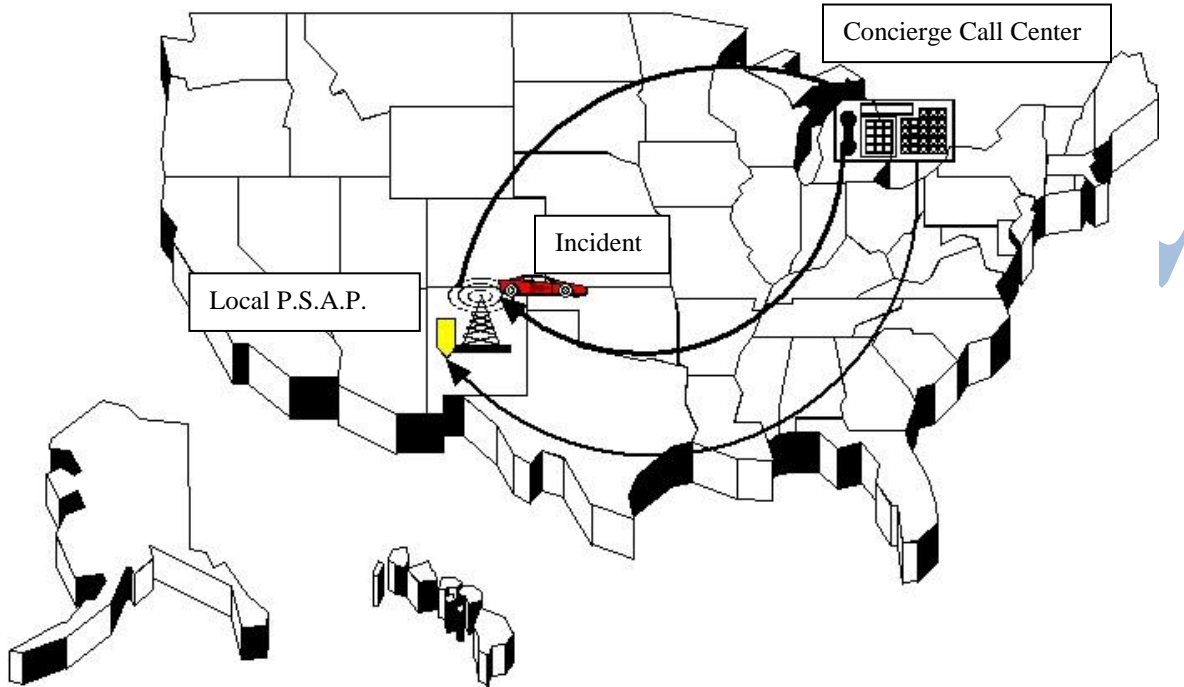

### 6.2.1 Discussion: Concierge Call Delivery (current-2000)

Either through direct action of an individual, or due to activation of sensors, a wireless call is established between the vehicle and a call taking position of a private sector concierge service center. The call taker determines the nature of the call and if appropriate performs a “nearest” search intended to identify the appropriate local P.S.A.P. Incident location may be determined by either query of the occupants with appropriate street based information or, polling onboard devices to determine the latitude/longitude (x,y). By dialing the local seven-digit number, the call taker then conferences the local P.S.A.P. This conference may involve the occupants if they are conscious or relays specific information regarding the location and nature of incident for local call processing if they are not.

**(ARCHIVED 20150922 FOR HISTORICAL PURPOSES)**

### 6.3 Localized Spatial Routing Concept

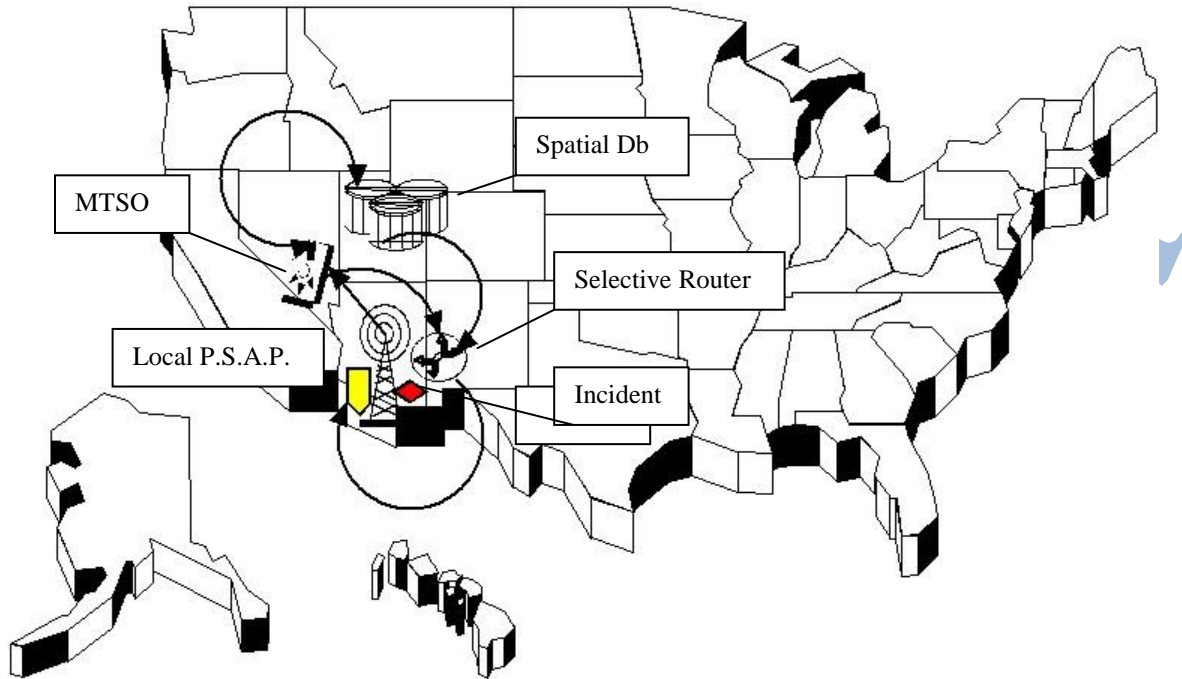

#### 6.3.1 Discussion: Localized Spatial Routing Concept

Conducting spatial routing (aka: Point-In-Polygon) with wireless technologies some basic considerations must be accommodated. In this diagram the “Incident” issues a call to 9-1-1. The wireless Location Determining Technology (LDT) determines the relative position expressed as latitude, longitude (x,y). The “MTSO” then queries a “Spatial Db” to request a point within a polygon that identifies the appropriate “Local P.S.A.P.” The appropriate local “Selective Router” is then dynamically updated with the Emergency Services Routing Digit (ESRD) and directs the “Incident” to the “Local P.S.A.P.” The “Local P.S.A.P.” may then query the dynamic ALI database (not shown) to retrieve the x,y for local processing.

**(ARCHIVED 20150922 FOR HISTORICAL PURPOSES)**

## 6.4 Non-Localized Spatial Routing Concept

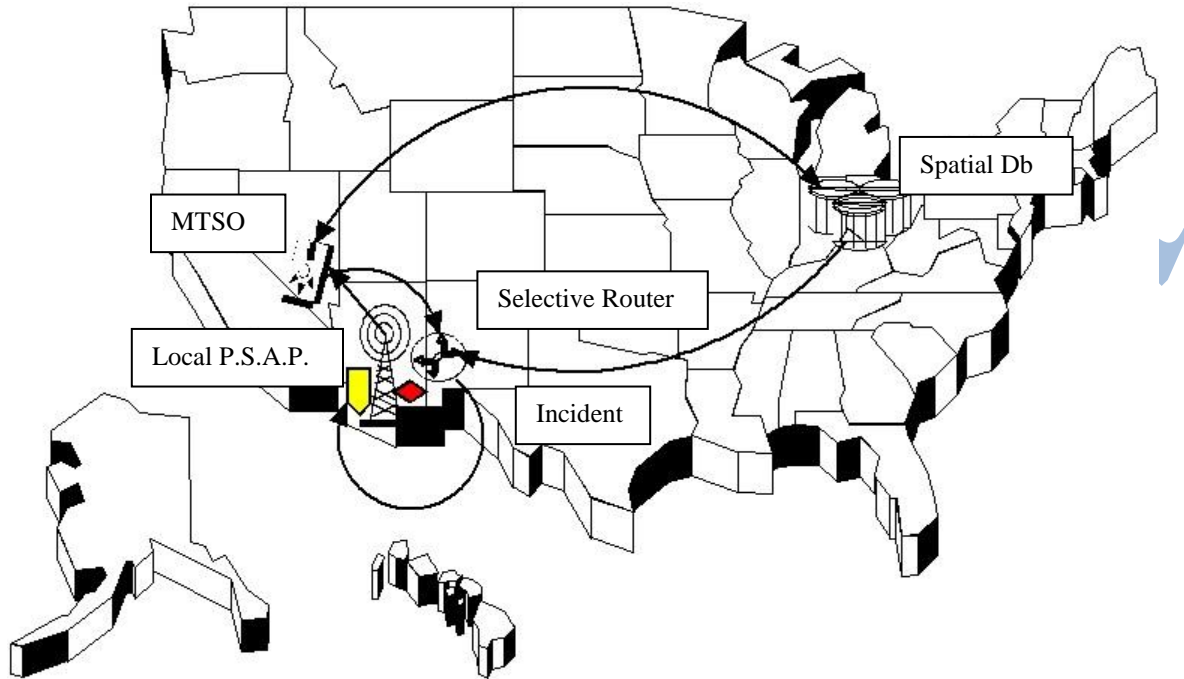

### 6.4.1 Discussion: Non-Localized Spatial Routing Concept

Conducting spatial routing (aka: Point-In-Polygon) with wireless when the Spatial Db is far removed presents unique challenges. In this diagram the "Incident" issues a call to 9-1-1. The wireless Location Determining Technology (LDT) determines the relative position expressed as latitude, longitude (x,y). The "MTSO" then queries the Non-Localized "Spatial Db" to request a point within a polygon that identifies the appropriate "Local P.S.A.P." The appropriate local "Selective Router" is identified and dynamically updated with the Emergency Services Routing Digit (ESRD) then directing the "Incident" to the "Local P.S.A.P." The "Local P.S.A.P." may then query the dynamic ALI database (not shown) to retrieve the x,y for local processing.

## 7 Glossary (<http://www.nena.org/?page=Glossary>)

<b>Term</b>	<b>Definition</b>
<i>ACN</i>	Automatic Collision Notification
<i>ArcNet</i>	
<i>Asynchronous Transfer Mode</i>	Multiplexed switching technology used to transport small fixed packets called “cells”.
<i>ATM</i>	According to "ATM Theory and Applications" by D.E. McDyson and D.L.Spohn, ATM is "A high speed, connection oriented multiplexing and switching method, specified in international standards, utilizing fixed length cells to support multiple types of traffic. It is asynchronous in the sense that cells carrying user data need not be periodic."
<i>Automatic Collision Notification</i>	The process of identifying that a motor vehicle has been involved in a collision, collecting data from sensors in the vehicle, and communicating that data to a Call Center or PSAP.
<i>Call Associated Signaling</i>	An architecture for the delivery of a wireless emergency call. The mobile callback number plus a number that identifies the cell/sector from which the call originated are transmitted with the voice call and delivered to the PSAP with the voice call, similar to the way ANI is delivered for wireline calls.
<i>CAS</i>	Call Associated Signaling
<i>Computer Telephony Integration</i>	Integrating telephone function into a computing device.
<i>CTI</i>	Computer Telephony Integration
<i>DHCP</i>	Dynamic Host Control Protocol
<i>DNS</i>	Domain Name Server
<i>Domain Name Server</i>	Computing device having a first octet of 172-190.
<i>Dynamic Host Control Protocol</i>	Assignment of an IP address to a client from a host that is only viable during any one established session.

<b>Term</b>	<b>Definition</b>
<b><i>Ethernet</i></b>	A local area network (LAN) architecture and product originally developed by Digital Equipment Corporation (DEC). Later standardized by IEEE as 802.3. Transmission on the network is governed by Carrier Sense Multiple Access with Collision Detection (CSMA/CD).
<b><i>Extensible Markup Language</i></b>	See XML document
<b><i>FDDI</i></b>	Fiber Optic interface
<b><i>Frame Relay</i></b>	ANSI data link level T 1.618
<b><i>IANA</i></b>	Internet Assigned Number Authority
<b><i>ICANN</i></b>	Internet Corporation Assigned Names and Numbers
<b><i>IETF</i></b>	Internet Engineering Task Force
<b><i>Intelligent Transport System</i></b>	Multi-disciplined plan, under the jurisdiction of the US Dept. of Transportation, to improve traffic flow..
<b><i>International Telecommunications Union – Telecommunications</i></b>	International standards body for all communication services.
<b><i>Internet Assigned Number Authority</i></b>	Responsible to assign public domain addresses
<b><i>Internet Corporation Assigned Names and Numbers</i></b>	Emerging authority for public domain addresses and URL's.

**(ARCHIVED 20150922 FOR HISTORICAL PURPOSES)**

**Internet Engineering Task Force** Lead standard setting authority for internet protocols

<b>Term</b>	<b>Definition</b>
<b>Internet Protocol</b>	Derivative of ARPANET using packets across digital links to move content.
<b>Internet Service Provider</b>	Subscriber based provider of services to the world wide web.
<b>Internet Telephony Service Provider</b>	Internet based telephony services.
<b>Ipv4</b>	Version 4 of the Internet Protocol
<b>ISP</b>	Internet Service Provider
<b>ITS</b>	Intelligent Transport System
<b>ITSP</b>	Internet Telephony Service Provider
<b>ITU-T</b>	International Telecommunications Union – Telecommunications
<b>NBMA</b>	Non Broadcast Multiple Access
<b>NCAS</b>	Non Call Associated Signaling
<b>Non Call Associated Signaling</b>	An alternative architecture to CAS for the delivery of a wireless emergency call. A routing number is transmitted with the voice call and delivered to the PSAP with the voice call. The routing number is then used to facilitate a database query, which yields the mobile callback number and cell/sector from which the call originated.
<b>Point-to-Point Protocol</b>	Imitating a virtual circuit by allowing only assigned addresses to communicate.

**(ARCHIVED 20150922 FOR HISTORICAL PURPOSES)**

<b><i>Polygon</i></b>	A shape that is closed, ie: circle, square, triangle or any derivative thereof
<b><i>PPP</i></b>	Point-to-Point Protocol
<b><i>QoS</i></b>	Quality of Service

<b><i>Term</i></b>	<b>Definition</b>
<b><i>Quality of Service</i></b>	Measurement of latency, packet loss and jitter.
<b><i>Radio Frequency</i></b>	Self explanatory.
<b><i>Real Time Protocol</i></b>	Bisync transmission without latency.
<b><i>Request for Comment</i></b>	A method by which standard setting bodies receive input from interested parties outside of the working group.
<b><i>RF</i></b>	Radio Frequency
<b><i>RFC</i></b>	Request for Comment
<b><i>RTP</i></b>	Real Time Protocol
<b><i>SAE</i></b>	Society of Automotive Engineers
<b><i>Society of Automotive Engineers</i></b>	US based engineering standard body for the automotive industry
<b><i>Spatial</i></b>	Concept of describing a space or area of space
<b><i>Telematics</i></b>	The system of components that supports two-way communications with a motor vehicle for the collection or transmission of information and commands.
<b><i>Token Ring</i></b>	Local area network architecture originally developed by IBM. Later standardized by IEEE as 802.5. Transmission on the network is governed by the possession of a "token" or specific octet of data. A station may only transmit when it receives the token.
<b><i>Uniform</i></b>	Mnemonic interpretation of the IP address.



**Resource  
Locator**

**URL** Uniform Resource Locator

**Version 4 of  
the Internet  
Protocol** The transmission of voice as packets of data, using the protocol originally developed for the Internet.

**VoDSL** Voice over Digital Subscriber Link

<b>Term</b>	<b>Definition</b>
<b>Voice over digital subscriber link</b>	Enabling digital voice transmission identical to voice over internet protocol but using digital subscriber services as the transport.
<b>Voice over internet protocol</b>	Voice that is sent over the internet as packets. Packets are assembled at either end of the transmission link.
<b>VoIP</b>	Voice over internet protocol
<b>Wireless Service Provider</b>	Cellular, satellite or other radio based telephony or data transport commercial entity.
<b>World Wide Web</b>	The public internet
<b>WSP</b>	Wireless Service Provider
<b>WWW</b>	World Wide Web
<b>x,y</b>	Shorthand expression for coordinates that identify a specific location in two dimensions. May represent latitude and longitude, UTM (Universal Transverse Mercator) coordinates or state plane coordinates.
<b>XML</b>	Extensible Markup Language