

# NENA

## Potential Points of Demarcation in NG9-1-1 Networks Information Document



NENA Potential Points of Demarcation in NG9-1-1 Networks Information Document

NENA-INF-003.1.1-2013

DSC Approval: 01/22/2013

PRC Approval: 03/01/2013

NENA Executive Board Approval: 03/21/2013

Prepared by:

National Emergency Number Association (NENA) Interconnection & Security Committee,  
Origination Access Network Sub-Committee, Demarcation Workgroup

Published by NENA

Printed in USA

**NENA  
INFORMATION DOCUMENT  
NOTICE**

This Information Document (INF) is published by the National Emergency Number Association (NENA) as an information source for the designers, manufacturers, administrators and operators of systems to be utilized for the purpose of processing emergency calls. It is not intended to provide complete design or operation specifications or parameters or to assure the quality of performance for systems that process such equipment or services.

NENA reserves the right to revise this Information Document for any reason including, but not limited to:

- Conformity with criteria or standards promulgated by various agencies,
- Utilization of advances in the state of the technical arts,
- Or to reflect changes in the design of equipment, network interfaces or services described herein.

This document is an information source for the voluntary use of communication centers. It is not intended to be a complete operational directive.

It is possible that certain advances in technology or changes in governmental regulations will precede these revisions. All NENA documents are subject to change as technology or other influencing factors change. Therefore, this NENA document should not be the only source of information used. NENA recommends that readers contact their 9-1-1 System Service Provider (9-1-1 SSP) representative to ensure compatibility with the 9-1-1 network, and their legal counsel to ensure compliance with current regulations.

Patents may cover the specifications, techniques, or network interface/system characteristics disclosed herein. No license expressed or implied is hereby granted. This document shall not be construed as a suggestion to any manufacturer to modify or change any of its products, nor does this document represent any commitment by NENA or any affiliate thereof to purchase any product whether or not it provides the described characteristics.

This document has been prepared solely for the use of E9-1-1 System Service Providers, network interface and system vendors, participating telephone companies, 9-1-1 Authorities, etc.

By using this document, the user agrees that NENA will have no liability for any consequential, incidental, special, or punitive damages arising from use of the document.

NENA's Committees have developed this document. Recommendations for change to this document may be submitted to:

National Emergency Number Association  
1700 Diagonal Rd, Suite 500  
Alexandria, VA 22314  
202-466-3911  
or [commleadership@nena.org](mailto:commleadership@nena.org)

*Copyright 2013 National Emergency Number Association, Inc.*

Acknowledgments:

The National Emergency Number Association (NENA) Interconnection & Security Committee, Origination Access Network Sub-Committee, Demarcation Workgroup developed this document. NENA recognizes the following industry experts and their companies for their contributions in development of this document.

**Executive Board Approval Date:** 03/21/2013

<b>Member</b>	<b>Company/Agency</b>
Anand Akundi	Telcordia
Angel Arocho	Comcast
Anna Hastings	AT&T
Bernard Brabant-ENP	Bernard Brabant, Consultant
Brad Herron	Hillsborough County 911, FL
Brandon Abley, WG Co-Leader	State of Minnesota
Brian Rosen	Neustar
Brian Kneuppel	Acme Packet
Carl Rodabaugh	Midland County 911, MI
Chuck Vick	Verizon
Dale Murray - ENP	Will County 911, IL
Dave Irwin	Pasco County, FL
David Watkins	Verizon
Dean Bourdens	AT&T
Duke Kaczmarczyk	Bandwidth.com
Greg Schumacher	Sprint
Guy Caron-ENP	Bell Canada
Jayne Nantkes	Akimeka
Jeff Torres	Verizon
Jim Shepard	Datamaster
John Hunt	TCS
Kelli Merriweather	CSEC, TX
Kevin Rohrer	CSEC, TX

Mark Neinast	AT&T
Melani LaCome	Bright House Networks Information Services
Mike Armstrong	Verizon
Mike Kennedy	AT&T
Mike Nelson	Intrado
Myron Herron	Synergem Emergency Services
Normand Fournier II	Massachusetts
Patrick Tyler	CSEC, TX
Paul McLaren	Intrado
Peter McHale	Verizon
Richard Atkins, ENP	Tarrant County 911, TX
Richard Muscat	Bexar Metro 911 TX
Richard Wu	Nokia Siemens Network
Rick Jones-ENP	NENA
Robert Sherry	Intrado
Roger Marshall	TCS
Roya Esfandi, WG Co-Leader	Verizon
Sam Bard	MicroDATA
Sandra Lott ENP	CenturyLink
Selena MacArthur	None (Individual)
Sharon Counterman	Greater Harris County 911, TX
Steven Zweifach	Sprint
Susan Sherwood	Verizon
Terry McLarty	Interact 911
Theresa Reese	Telcordia
Tim Barry	AT&T
Victoria Zeller	Sprint

This working group also thanks Pete Eggimann and Tony Busam, Development Steering Council Co-Chairs; Roger Hixson, Technical Issues Director; and Ty Wooten, Director of Education and Operational Issues Director.

## Table of Contents

<b>1</b>	<b>EXECUTIVE OVERVIEW .....</b>	<b>7</b>
<b>2</b>	<b>INTRODUCTION.....</b>	<b>8</b>
2.1	OPERATIONS IMPACTS SUMMARY.....	8
2.2	TECHNICAL IMPACTS SUMMARY .....	8
2.3	SECURITY IMPACTS SUMMARY .....	8
2.4	DOCUMENT TERMINOLOGY .....	8
2.5	REASON FOR ISSUE/REISSUE.....	8
2.6	RECOMMENDATION FOR ADDITIONAL DEVELOPMENT WORK .....	9
2.6.1	<i>Regulatory Issues.....</i>	9
2.6.2	<i>QoS/SLA Assurance.....</i>	9
2.6.3	<i>VoIP Origination that Traverses an i2-based VSP Network .....</i>	9
2.6.4	<i>Policy and Financial Issues Regarding Demarcation of the LNG .....</i>	10
2.6.5	<i>Contingency Routing .....</i>	10
2.7	DATE COMPLIANCE .....	10
2.8	ANTICIPATED TIMELINE.....	11
2.9	COST FACTORS .....	11
2.10	COST RECOVERY CONSIDERATIONS.....	11
2.11	ADDITIONAL IMPACTS (NON COST RELATED) .....	11
2.12	INTELLECTUAL PROPERTY RIGHTS POLICY.....	11
2.13	ACRONYMS/ABBREVIATIONS, TERMS AND DEFINITIONS .....	11
<b>3</b>	<b>CONCEPTUAL VIEW OF DEMARICATION IN NG9-1-1 .....</b>	<b>14</b>
<b>4</b>	<b>PHYSICAL DEMARICATION POINTS .....</b>	<b>16</b>
<b>5</b>	<b>LOGICAL DEMARICATION POINTS .....</b>	<b>17</b>
5.1	BORDER CONTROL FUNCTION (BCF) .....	17
5.2	MAP OF POTENTIAL POINTS OF LOGICAL DEMARICATION .....	19
5.3	INDEX OF POINTS WHERE INTERFACES CREATE POTENTIAL POINTS OF LOGICAL DEMARICATION .....	19
5.3.1	<i>Legacy Wireline Origination .....</i>	20
5.3.2	<i>Legacy Wireless Origination Using WCM Approach.....</i>	21
5.3.3	<i>Legacy Wireless NCAS Origination Routed to i3 PSAP.....</i>	22
5.3.4	<i>IP Origination .....</i>	22
5.3.5	<i>Termination to Legacy PSAP via LPG .....</i>	23
5.3.6	<i>Location Validation.....</i>	23
5.3.7	<i>ECRF/LVF Provisioning .....</i>	23
<b>6</b>	<b>DEMARICATION ASSOCIATED WITH LEGACY GATEWAYS .....</b>	<b>23</b>
6.1.1	<i>Demarcation for the LNG.....</i>	23
6.2	FUNDAMENTAL DIFFERENCES BETWEEN DEMARICATION A AND B .....	25
6.2.1	<i>Quantity of LNGs.....</i>	25
6.2.2	<i>Transport.....</i>	25
6.2.3	<i>Protocol and Standard Variation .....</i>	26
6.3	DEMARICATION OF THE LSRG.....	26
6.4	DEMARICATION FOR THE LPG .....	28
<b>7</b>	<b>RECOMMENDED READING AND REFERENCES.....</b>	<b>29</b>

8 RECOMMENDED READING AND REFERENCES.....30  
9 EXHIBITS .....30  
10 APPENDIX.....30  
11 PREVIOUS ACKNOWLEDGMENTS.....30

ARCHIVED

## 1 Executive Overview

In legacy telecommunications networks, points of demarcation are relatively straightforward: (a) originating carrier networks interconnect with the carrier that is designated as the 9-1-1 service provider for a given Public Safety Answering Point (PSAP) at agreed upon points of interconnection (POIs) pursuant to existing interconnection agreements (ICAs), and (b) the 9-1-1 service provider then utilizes its existing legacy emergency services network to route and deliver the calls through discrete circuits which are connected to the PSAP's facilities at a clear point of demarcation, typically a network interface device (NID) located at or near the customer premises. The POI in a legacy environment typically occurs at a telephone company central office. This POI is physically located at a junction panel or similar point within the central office.

In NG9-1-1 networks, demarcation is not defined exclusively by a physical point of interconnection. NG9-1-1 is built on Internet Protocol (IP) networks which follow the Open Systems Interconnection (OSI) layered model where points of demarcation can occur independently at different places in different OSI layers.

In a legacy telecommunications environment, the 9-1-1 service and the facilities are generally provided by the same entity. In NG9-1-1 individual entities may contribute all or a portion of the resources that make up the network. Furthermore, the requirement for resiliency and redundancy for NG9-1-1 network, components, elements, applications, etc. may involve a combination of distinct entities, and consequently many demarcation points.

Demarcation in NG9-1-1 can be sorted into two types: Physical Demarcation and Logical Demarcation. Physical Demarcation points are between the actual hardware within the NG9-1-1 network and between the NG9-1-1 network and (a) the originating carrier networks, and (b) the PSAP facilities, while Logical Demarcation points are determined by interfaces between functional elements within an NG9-1-1 network and those devices and/or applications that interact with the NG9-1-1 network. Compared to the OSI models, physical points of demarcation in NG9-1-1 occur on layer 1, the physical layer, while logical points of demarcation occur on the remaining layers 2-7.

A demarcation point is a mutually-defined boundary dividing one area of responsibility from another. A demarcation point has no meaning unless all stakeholders agree on its location, such as if that location is specified by industry standards or regulations, and so it is critical that a demarcation point is established through consensus.

The parties responsible for network elements or functions on one side of a demarcation point are responsible to ensure that those elements or functions are operating properly and to specification up to, and not beyond, that point. This responsibility does not necessarily indicate ownership, as elements of the network may be leased or provided by a third party. The party responsible for each element may be expected to fund implementation, maintenance, upgrades, and any other costs necessary to ensure proper operation. The party responsible may elect to own and operate a network element it is responsible for, or may elect to contract with a third party for those services.

There are operational impacts associated with any newly identified type of demarcation. These newly identified points have new and different interfaces for physical interconnection, data, and

transport. Where these points of demarcation are identified can have a significant impact on the architecture of the network itself, and can shift costs and responsibilities accordingly.

Two important points of demarcation in NG9-1-1 are between (1) the Legacy Network Gateway (LNG) and legacy TDM-based originating networks; and (2) between the Emergency Services IP Network (ESInet) and other networks, found in the Session Border Controller (SBC). In general, the point of logical demarcation for a Time Division Multiplex (TDM) connection is the Legacy Network Gateway, and the point of logical demarcation for a Session Initiation Protocol (SIP) connection is the Border Control Function (BCF).

This document's purpose is to identify points of demarcation, and not to advise on the relative merits of different demarcation options from a regulatory or financial perspective.

## 2 Introduction

### 2.1 Operations Impacts Summary

No significant changes to PSAP operations are anticipated due to configuration of demarcation in NG9-1-1.

### 2.2 Technical Impacts Summary

Configuration of demarcation has substantial impacts to the overall architecture of the network. A certain number of key demarcation points (for example, placement of legacy gateways) will substantially influence how a particular deployment manages legacy TDM network infrastructure versus SIP-based IP network infrastructure. For more information, see Section 3.

### 2.3 Security Impacts Summary

This document does not explore security impacts associated with points of demarcation in NG9-1-1 in any great detail.

For greater detail on security in NG9-1-1, please refer to NENA Security for Next-Generation 9-1-1 Standard (NG-SEC) NENA 75-001 (latest version as of this writing Version 1, February 6, 2010).

### 2.4 Document Terminology

The terms "shall", "must" and "required" are used throughout this document to indicate required parameters and to differentiate from those parameters that are recommendations. Recommendations are identified by the words "desirable" or "preferably".

### 2.5 Reason for Issue/Reissue

NENA reserves the right to modify this document. Upon revision, the reason(s) will be provided in the table below.

Version	Approval Date	Reason For Changes
NENA-INF-003.1-2013	03/21/2013	Initial Document
NENA-INF-003.1.1-2013	05/30/2015	Update web page links

NENA-INF-003.1.1-2013	03/17/2020	Archived
-----------------------	------------	----------

## 2.6 Recommendation for Additional Development Work

Additional work is required in this topic area to investigate policy and financial impacts associated with demarcation options. This is a technical document and does not explore policy or financial issues.

### 2.6.1 Regulatory Issues

This document does not explore the regulatory issues associated with the various options for demarcation. This topic calls for a detailed analysis of any and all regulatory impacts associated with the various options for demarcation. For example, carriers, equipment providers, and service providers may be required to implement certain technologies in order to transmit data to interfaces provided by the 9-1-1 authority, and vice-versa. For example, existing regulation<sup>1</sup> requires wireless carriers to deliver calls to Selective Routers at the carrier's own cost. The LNG input is the same interface as the Selective Router, but the ESRP, with an IP input, provides the equivalent function of the selective router. And so, whether this regulation applies in an NG environment, and if so, how that regulation is interpreted, is an outstanding issue outside the scope of a technical document. More important, the nature and scope of standards set by or incorporated into applicable regulations will have a material impact on the implementation and application of demarcation points and associated interfaces and gateways.

### 2.6.2 QoS/SLA Assurance

As of this writing, there are no existing NENA recommendations for quality or service levels in an NG environment. The industry needs guidance towards parameters and suggested values to be incorporated in quality and service agreements in NG911.

### 2.6.3 VoIP Origination that Traverses an i2-based VSP Network

As described in NENA 08-001, a VoIP emergency call origination may traverse an NENA i2 Standard-based VSP network, and be delivered to a legacy SR via an i2 Emergency Services Gateway (ESGW). In a transitional environment, these calls may be routed to an i3 ESInet via a LNG rather than being routed to a legacy SR.

As of this writing, NENA has not published a recommended call flow for this type of call, and so, this document will not contain an index of potential points of demarcation at the LNG for this call type.

---

<sup>1</sup> Letter from Thomas J. Sugrue, Chief, Wireless Telecommunications Bureau, Federal Communications Commission, to Marlys R. Davis, E911 Program Manager, King County E-911 Program Office, Department of Information and Administrative Services, dated May 7, 2001.

#### **2.6.4 Policy and Financial Issues Regarding Demarcation of the LNG**

Configuration of demarcation for the LNG has some interdependencies with the rollout schedule for actually implementing the equipment. As of this writing, there exists no clear precedent for the migration path from and SR(s)-only environment to one which uses LSRG(s) and/or LNG(s). For example, demarcation of the LNG determines which party owns the LNG and may accordingly change its rollout schedule.

There are only NENA Technical standards for the LNG specified in (NENA 08-003). Carrier-recognized standards, such as those developed by 3GPP or other carrier standards bodies may be needed if the carrier owns the LNG.

Deployment of the LNG is currently an unknown cost in future NG911 networks. Demarcation is the primary catalyst for shifting cost towards either party, and as there exists no consensus for a single form of demarcation, there exists no clear guidance for determining the responsibility for funding the LNG. This would appear to call for the development and of regulations to establish standardized demarcation points and the respective roles and responsibilities of the parties.

Alarm monitoring features may be impacted from an ownership and notification perspective. Technically, there is no reason why either Demarcation A or Demarcation B can be supported for the LNG on a case-by-case basis.

The LNG can be decomposed into 3 or more components as well as the points of demarcation between those components. There is no standardization for those components or the interfaces between those components presently.

Within NENA there is presently an effort to define the method by which the LNG routes wireless calls. It is not anticipated that this effort will affect any demarcation issues.

#### **2.6.5 Contingency Routing**

It is the finding of the workgroup that contingency routing, including overflow, default and diverse routing are not impacted by demarcation options from a technological perspective. However, there are potential policy issues associated with contingency routing that warrant future study, such as the content of Service Level Agreements (SLAs) and regulations that may vary depending on the configuration of demarcation.

#### **2.7 Date Compliance**

All systems that are associated with the 9-1-1 process shall be designed and engineered to ensure that no detrimental, or other noticeable impact of any kind, will occur as a result of a date/time change up to 30 years subsequent to the manufacture of the system. This shall include embedded application, computer based or any other type application.

To ensure true compliance, the manufacturer shall upon request, provide verifiable test results to an industry acceptable test plan such as Telcordia GR-2945 or equivalent.

## 2.8 Anticipated Timeline

There are no special impacts to deployment timelines associated with points of demarcation in NG9-1-1.

## 2.9 Cost Factors

How points of demarcation are configured in NG9-1-1 will determine, in large part, which parties pays for which elements of the NG9-1-1 system. However, this document focuses only on potential points where demarcation does exist; it does not explore the financial impacts of different configurations and endorses no one particular approach over any other.

## 2.10 Cost Recovery Considerations

This document provides no recommendations or input regarding cost recovery mechanisms.

## 2.11 Additional Impacts (non cost related)

This document focuses exclusively on the technical topic of identifying potential points of demarcation in NG9-1-1 and highlights on a small number of points where the configuration of demarcation has a substantial influence on the overall network architecture.

## 2.12 Intellectual Property Rights Policy

NENA takes no position regarding the validity or scope of any Intellectual Property Rights or other rights that might be claimed to pertain to the implementation or use of the technology described in this document or the extent to which any license under such rights might or might not be available; nor does it represent that it has made any independent effort to identify any such rights.

NENA invites any interested party to bring to its attention any copyrights, patents or patent applications, or other proprietary rights that may cover technology that may be required to implement this standard.

Please address the information to:

National Emergency Number Association  
1700 Diagonal Rd, Suite 500  
Alexandria, VA 22314  
202-466-3911  
or [commleadership@nena.org](mailto:commleadership@nena.org)

## 2.13 Acronyms/Abbreviations, Terms and Definitions

Some acronyms/abbreviations, terms and definitions used in this document may have not yet been included in the master glossary. After initial approval of this document, they will be included. See NENA Master Glossary of 9-1-1 Terminology located on the [NENA web site](#) for a complete listing of terms used in NENA documents. All acronyms used in this document are listed below, along with any new or updated terms and definitions.

**The following Acronyms are used in this document:**

<b>The following Acronyms are used in this document:</b>		
<b>Acronym</b>	<b>Description</b>	<b>** N)ew (U)pdate</b>
<i><b>3GPP</b></i>	3 <sup>RD</sup> Generation Partner Project	
<i><b>ALI</b></i>	Automatic Location Identification	
<i><b>API</b></i>	Application Programming Interface	
<i><b>BCF</b></i>	Border Control Function	
<i><b>CIDB</b></i>	Call Information Database	
<i><b>CPE</b></i>	Customer Premises Equipment	
<i><b>DACS</b></i>	Digital Access Cross-Connect System	N
<i><b>DTMF</b></i>	Dual Tone Multi Frequency	
<i><b>ECRF</b></i>	Emergency Call Routing Function	
<i><b>ESInet</b></i>	Emergency Services IP Network	
<i><b>E2, E2+</b></i>	Interface between MPC/GMLC and ESME (TIA/EIA/J-STD-036, NENA 05-001)	N
<i><b>E-MF</b></i>	Enhanced - Multi-Frequency	N
<i><b>EO</b></i>	End Office	
<i><b>ESN</b></i>	Emergency Services Number	
<i><b>ESME</b></i>	Emergency Services Message Entity	
<i><b>ESRP</b></i>	Emergency Services Routing Proxy	
<i><b>ESGW</b></i>	Emergency Services Gateway	N
<i><b>GMLC</b></i>	Gateway Mobile Location Center	
<i><b>GR</b></i>	Generic Requirements	N
<i><b>HELD</b></i>	HTTP-Enabled Location Delivery Protocol	
<i><b>i2</b></i>	NENA 08-001 - Interim VoIP Architecture for Enhanced 9-1-1 Services (i2)	
<i><b>i3</b></i>	NENA 08-003 - Detailed Functional And Interface Standard for NG9-1-1 (i3)	N
<i><b>IETF</b></i>	Internet Engineering Task Force	
<i><b>IP</b></i>	Internet Protocol	
<i><b>LIF</b></i>	Location Interwork Function	N

<b>The following Acronyms are used in this document:</b>		
<i>LIS</i>	Location Information Server	
<i>LoST</i>	Location to Service Translation	
<i>LRF</i>	Location Retrieval Function	
<i>LNG</i>	Legacy Network Gateway	N
<i>LPG</i>	Legacy PSAP Gateway	N
<i>LSRG</i>	Legacy Selective Router Gateway	N
<i>MCS</i>	MSAG Conversion Services	N
<i>MF</i>	Multi-Frequency	
<i>MLP</i>	Mobile Location Protocol	
<i>MSAG</i>	Master Street Address Guide	
<i>MSC</i>	Mobile Switching Center	
<i>NCAS</i>	Non Call-Path Associated Signaling	
<i>NENA</i>	National Emergency Number Association	
<i>NG9-1-1</i>	Next Generation 9-1-1	
<i>NIF</i>	NG9-1-1 Specific Interwork Function	N
<i>OMA</i>	Open Mobile Alliance	
<i>OSI</i>	Open Systems Interconnection	
<i>OSS</i>	Operational Support Systems	N
<i>PAM</i>	PSAP to ALI Message Specification	
<i>pANI</i>	Pseudo Automatic Number Identification	
<i>PIF</i>	Protocol Interworking Function	N
<i>PSAP</i>	Public Safety Answering Point or Primary Public Safety Answering Point	
<i>RFC</i>	Request For Comments	
<i>RTP</i>	Real Time Transport Protocol	
<i>SBC</i>	Session Border Controller	
<i>SOI</i>	Service Order Input	
<i>SIP</i>	Session Initiation Protocol	
<i>SLA</i>	Service Level Agreement	

<b>The following Acronyms are used in this document:</b>		
<b>SR</b>	Selective Routing, Selective Router [a.k.a., E9-1-1 Tandem, or Enhanced 9-1-1 (E9-1-1) Control Office]	
<b>SS7</b>	Signaling System 7	
<b>SSP</b>	System Service Provider	N
<b>TDM</b>	Time Division Multiplexing	
<b>TRD</b>	Technical Requirements Document	
<b>UA</b>	User Agent	
<b>UE</b>	User Equipment	
<b>URI</b>	Uniform Resource Identifier	
<b>VoIP</b>	Voice over Internet Protocol	
<b>VSP</b>	VoIP Service Provider	
<b>WCM</b>	Wireline Compatibility Mode	

<b>The following Terms and Definitions are used in this document:</b>		
<b>Term</b>	<b>Definition</b>	<b>** N)ew (U)date</b>
Demarcation Point	A mutually-defined boundary dividing one area of responsibility from another.	N
Physical Demarcation	A mutually-defined boundary dividing one area of responsibility for managing tangible assets, such as computers, routing hardware, or transmission lines from another.	N
Logical Demarcation	A mutually-defined boundary dividing one area of responsibility for managing NG9-1-1 functional elements from another. The interfaces for these functional elements include the interfaces for intangible assets, such as data stores and applications.	N
POI	A Physical Demarcation between an originating carrier network and an NG9-1-1 network.	N

### 3 Conceptual View of Demarcation in NG9-1-1

A demarcation point is a mutually-defined boundary dividing one area of responsibility from another. All parties to a demarcation point must agree to that demarcation point, or the demarcation point must be established by an industry standard or governmental regulation, or else the demarcation point has no meaning. Consensus upon points of demarcation should be documented in

a written and signed agreement such as a contract, MOU, or equivalent. In NG9-1-1, there are two types of demarcation:

1. **Physical Demarcation:** A mutually-defined boundary dividing one area of responsibility for managing tangible assets, such as computers, routing hardware, or transmission lines from another.
2. **Logical Demarcation:** A mutually-defined boundary dividing one area of responsibility for managing NG9-1-1 functional elements from another. The interfaces for these functional elements include the interfaces for intangible assets, such as data stores and applications.

Points of demarcation can occur in both types for any one particular use case, but not always at the same point. These points can represent complex inter-relationships between many parties. Many functional elements fulfilled by software applications may be on a single piece of hardware, or redundant instances of the same software may be installed on many different servers. Following are two examples of the sorts of complex relationships that may exist:

1. An IP network client has a single physical connection to the network, but connects to many functional elements within the network over that single physical connection. In this example, there is a single point of Physical Demarcation paired with many points of Logical Demarcation.
2. A PSAP's network cable plugs into the input of the NG9-1-1 provider's access router firewall. In this example, the Physical demarcation point is at that connection to the firewall. The corresponding Logical Demarcation point for this interaction occurs where the PSAP's CPE interacts with the BCF when interfacing with the Emergency Services Routing Proxy (ESRP), independent of the physical hardware enabling this interaction.

There may be additional specific administrative boundaries corresponding to a particular demarcation point, but they do not affect demarcation from a technical perspective.

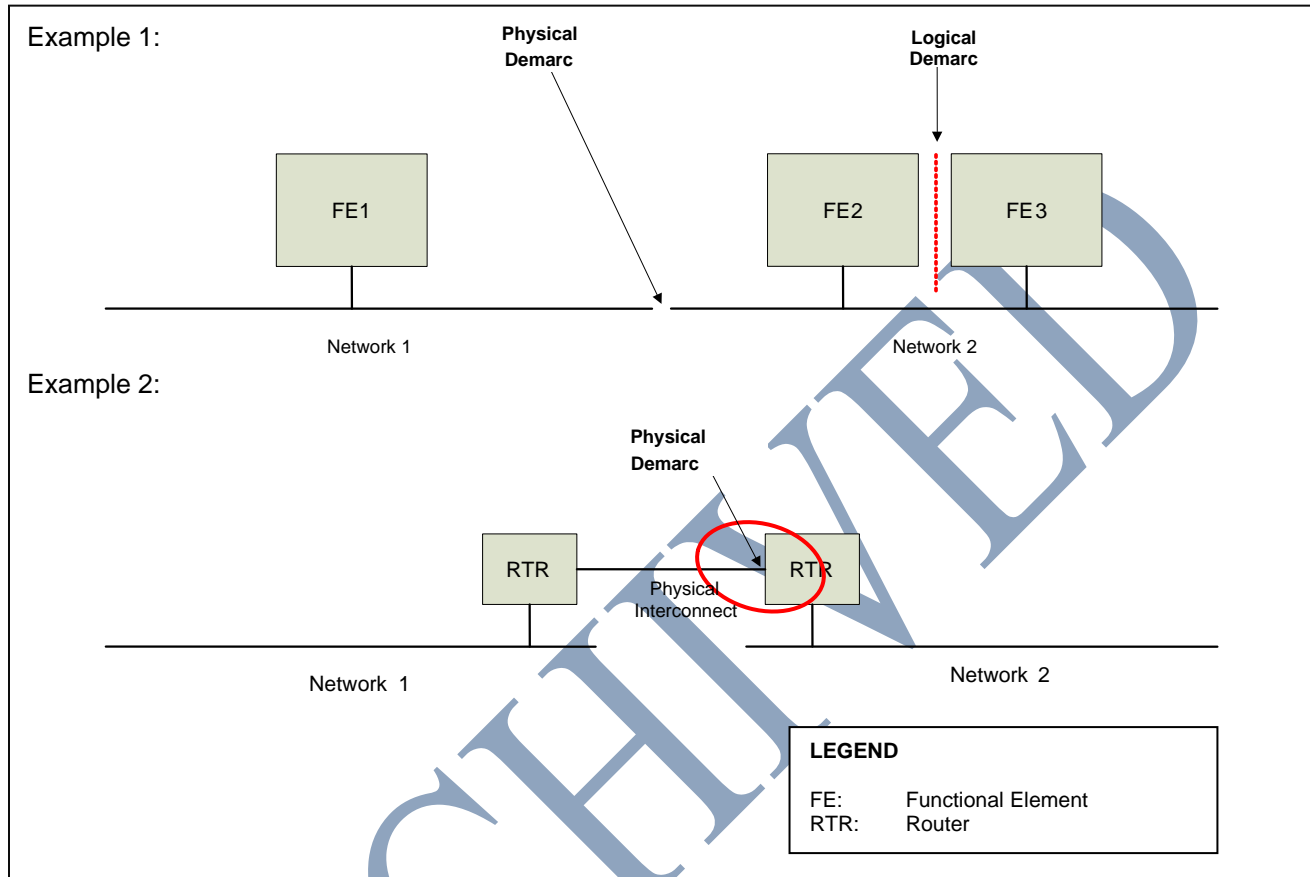

Figure 1: Examples of Physical and Logical Demarcation.

#### 4 Physical Demarcation Points

A point of Physical Demarcation is at a *connection*. Physical Demarcation points occur where a physical boundary exists between two domains of network infrastructure or hardware. At a Physical Demarcation point, one entity's facilities connect to another entity's facilities. Physical Demarcation defines the boundary of responsibility for tangible network elements such as a router, firewall hardware, an application server, or a Digital Access Carrier System (DACS).

A Physical Demarcation point will be found where one device connects to another, such as where an incoming transmission line actually plugs into a jack on rack-mounted equipment in end-office facilities. From a single physical point of demarcation multiple Logical Demarcations may be reached. This concept is described more in the Logical Demarcation section.

A Physical Demarcation point in NG9-1-1 will almost always occur at the input jack of an access router or firewall. This is the case because a router is a device that forwards data packets between telecommunications networks, and a firewall moderates access to a network.

Prior to the end of end-to-end IP connectivity for emergency calls, a Physical Demarcation point may also occur at a gateway device, such as an LNG, Legacy PSAP Gateway (LPG), Legacy Selective Router Gateway (LSRG), or at the facility endpoint for any legacy telecommunications services.

Following are some examples of potential points of Physical Demarcation:

1. The connection to a BCF, where a network cable physically plugs into the input of the hardware fulfilling the BCF functional element. At this point, there is a demarcation point at the BCF moderating input to the ESInet.
2. The connection on the TDM side to an LNG, LSRG, or LPG, where wires or cable connect to the hardware fulfilling those functional elements. At this point, legacy traffic is converted into an NG9-1-1-compatible SIP format. It is possible that the SIP side of this connection is provided by a different entity than the origination network, and so, this is a potential point of demarcation.
3. The connection to a firewall at the edge of a PSAP's network. At this point, hardware owned by the ESInet provider may cease and any hardware on the other side of this connection is owned by the PSAP.

Redundant elements and redundant communication paths do not necessarily change the nature of any demarcation points; if the elements are fully redundant, then each redundant element has the same demarcation point as the other as they are identical. While the owner of each instance may be different, the demarcation point should be the same.

## 5 Logical Demarcation Points

A point of Logical Demarcation is at an *interface*. Logical Demarcation points are determined by the interfaces between functional elements within an NG9-1-1 network and those devices and/or applications that interact with the NG9-1-1 network.

Every Functional Element in NG9-1-1 is a potential point of demarcation, as is any application interacting with it.

Points of logical demarcation may not correlate directly with the points of Physical Demarcation. For example, consider an IP network connection between an originating carrier and an NG9-1-1 network. The Physical Demarcation (POI) between these entities may be a router connection between the carrier's network and the NG9-1-1 provider's ESInet. Over that physical connection, SIP calls may be sent between the SBC (session border controller) in the carrier and the BCF at the edge of the ESInet. Thus, the BCF represents a logical connection over which SIP emergency calls pass. Specific service level agreements, protocol specifications and monitoring and maintenance responsibilities exist at this demarcation point.

### 5.1 Border Control Function (BCF)

NENA 08-003, Detailed Functional and Interface Specification for the NENA i3 Solution, specifies that NG9-1-1 systems must be capable of interworking with broader telecommunications and applications types, which will include IP based interfaces between networks. These IP interfaces can

exist between ESInets, between an ESInet and a PSAP, between a service provider network and an ESInet, or between any two IP networks (or 'borders').

A BCF sits between external networks and the ESInet and between the ESInet and agency networks. All traffic from external networks transits a BCF as per NENA ESInet Design for NG9-1-1 NENA 08-506. The BCF functional element secures the connection between networks, and has well defined roles and position in an i3 network as outlined in NENA 08-003. The SBC component of the BCF protects against VoIP specific and general Distributed Denial of Service (DDoS) attacks on VoIP network elements.

The BCF scans and eliminates known malware attacks from extranet and intranet sources before they ever reach a user's workstation or a production server or another end point located inside the ESInet. Although one may occasionally refer to the traffic as being "in transit", calls may actually be terminated and regenerated at the BCF IP address and ports for all signaling and media, therefore making the BCF a likely logical demarcation point for most external networks.

For example, when a service provider or PSAP directs calls to an IP address at the ESInet, the external network is actually communicating with an ESInet BCF. The "Originating ESRP" is the first routing element inside the ESInet. It receives calls from the BCF at the edge of the ESInet. The "Terminating ESRP" is typically at the edge of a PSAP, just past the PSAP BCF. The ESInet operator is responsible for the BCF at the edge of the ESInet, and the PSAP or other agency is responsible for a BCF between its network and the ESInet. More information about the BCF is available in NENA 08-003 relative to upstream and downstream flows to and from the BCF.

External calls are directed to an ESInet based on an ECRF query and response. Regardless of the actual content of the domain name or IP address the ECRF response resolves to, all calls will transit the BCF at the entrance to the ESInet. Some implementations of a BCF will actually terminate the SIP signaling, and regenerate signaling inside the ESInet towards the ESRP. Others may just provide passive DDoS and other protection to the signaling and the SIP messages will terminate on an internal ESRP.

It may be unclear where exactly the demarcation point is: at the BCF, which is the boundary to the network, or the ESRP, which is the functional element that external networks interact with. This distinction is an internal matter for the ESInet, and the origination network's elements do not care. The call is sent to the address provided by the external ECRF and the element that responds is the logical demarcation point.

## 5.2 Map of Potential Points of Logical Demarcation

Following is a map of potential points of Logical Demarcation. These points are identified where one functional element interfaces with another.

Any interface between two or more functional elements is a potential point of demarcation for those functional elements. This is because devices and applications in an IP network are relatively free to send or receive data from any other device on the network. Under the i3 framework, devices and applications will behave in a predictable fashion—transmitting and receiving data from those other functions for which there is a standardized interface. It is at those pre-defined interfaces that there exists a potential point of logical demarcation.

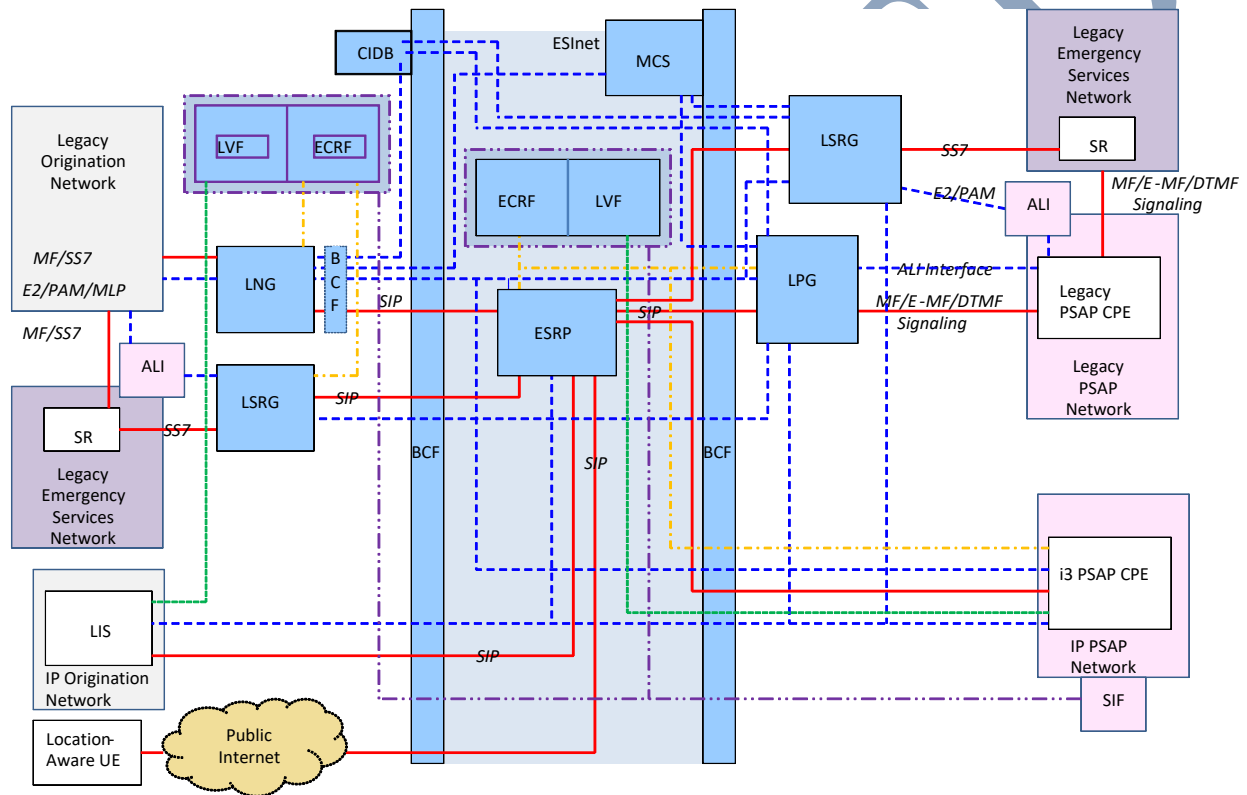

SIF (Spatial Information Fn)	LVF (Location Validation Fn)	Location Validation	Provisioning	OrigNetwork
SR (Selective Router)	LPG (Legacy PSAP GW)	ECRF (Emergency Call Routing Function)	Signal Path	i3 Elements
LSRG (Legacy SR GW)	LIS (Location Info Server)	ESRP (Emergency Services Routing Protocol)	Location/Data Retrieval	PSAP Elements
LNG (Legacy Network GW)	MCS (MSAG Conversion Svc)	CIDB (Call Information DB)	Routing Query	Legacy ESN

Figure 2: Map of Interfaces with Potential Logical Points of Demarcation

## 5.3 Index of Points Where Interfaces Create Potential Points of Logical Demarcation

Following is an index of points where interfaces and interactions between Functional Elements create the potential for Logical Demarcation in NG9-1-1. There is the potential for demarcation wherever there are functional elements interfacing with other functional elements or where a

functional element provides an interface for applications to interact with the functional element. These interfaces are described in NENA 08-003 and 77-501.

### **5.3.1 Legacy Wireline Origination**

#### **5.3.1.1 TDM LSRG legacy interfaces**

LSRG-SS7: LSRG to SR (SS7 tandem to tandem transfer)

LSRG-ALI: LSRG to ALI system (ALI query + response)

LSRG-E2: LSRG to ALI system (E2+, MLP, PAM location query)

#### **5.3.1.2 IP LSRG interfaces through IP signaling interfaces**

LSRG-LoST: LSRG to ECRF (LoST query and response)

LSRG-LIS: LSRG to LIS (SIP/held location de-reference)

LSRG-CIDB: LSRG to CIDB (http additional data de-reference)

LSRG-MCS: LSRG to MCS (http MSAG conversion service)

LSRG-SIP: LSRG to ESRP (SIP call)

LSRG-RTPPSAP: LSRG to PSAP (RTP for media)

LSRG-RTPUA: LSRG to UA (RTP for media)

#### **5.3.1.3 TDM LNG legacy interfaces**

LNG-SS7: LNG to EO/MS (SS7 call)

LNG-E2: LNG to MPC (E2+, PAM, MLP location query)

LNG-PROV: LNG to OSS (ALI SOI)<sup>2</sup>

#### **5.3.1.4 IP LNG interfaces through IP signaling interfaces**

LNG-LoST: LNG to ECRF (LoST query and response)

LNG-Loc: PSAP to LNG (SIP/held location de-reference)

LNG-CIDB: LNG to CIDB (http additional data de-reference)

LNG-MCS: LNG to MCS (http MSAG conversion service)

LNG-SIP: LNG to ESRP (SIP call)

LNG-RTPPSAP: LNG to PSAP (RTP for media)

---

<sup>2</sup> If the demarc of the LNG is on the TDM side, the LNG provisioning interface should be standardized through other efforts. As of this writing, it is not. If the demarc of the LNG is on the IP side, the interface is not an issue.

## **5.3.2 Legacy Wireless Origination Using WCM Approach**

### **5.3.2.1 TDM LSRG legacy interfaces**

LSRG-SS7: LSRG to SR (SS7 tandem to tandem transfer)

LSRG-ALI: LSRG to ALI system (ALI query + response)

LSRG-E2/MLP: LSRG to ALI system (E2+/OMA-MLP, PAM location query)

### **5.3.2.2 IP LSRG interfaces through IP signaling interfaces**

LSRG-LoST: LSRG to ECRF (LoST query and response)

LSRG-LIS: LSRG to LIS (SIP/held location de-reference)

LSRG-CIDB: LSRG to CIDB (http additional data de-reference)

LSRG-MCS: LSRG to MCS (http MSAG conversion service)

LSRG-SIP: LSRG to ESRP (SIP call)

LSRG-RTPPSAP: LSRG to PSAP (RTP for media)

LSRG-RTP Bridge: LSRG to Bridge (RTP for media)

### **5.3.2.3 TDM LNG legacy interfaces**

LNG-SS7: LNG to EO/MSC (SS7 call)

LNG-E2: LNG to MPC/GMLC (E2+/OMA-MLP, PAM location query)<sup>3</sup>

LNG-PROV: LNG to OSS (ALI SOI)

### **5.3.2.4 IP LNG interfaces through IP signaling interfaces**

LNG-LoST: LNG to ECRF (LoST query and response)

LNG-Loc: PSAP to LNG (SIP/held location de-reference)

LNG-CIDB: LNG to CIDB (http additional data de-reference)<sup>4</sup>

LNG-MCS: LNG to MCS (http MSAG conversion service)

LNG-SIP: LNG to ESRP (SIP call)

LNG-RTP Bridge: LNG to Bridge (RTP for media)

LNG-RTPPSAP: LNG to PSAP (RTP for media)

---

<sup>3</sup> See footnote 2

<sup>4</sup> If the 9-1-1 authority runs the CIDB separately there may be a demarc at this interface. Otherwise, the CIDB is within the LNG.

### **5.3.3 Legacy Wireless NCAS Origination Routed to i3 PSAP**

#### **5.3.3.1 TDM LSRG legacy interfaces**

LSRG-SS7: LSRG to SR (SS7 tandem to tandem transfer)

LSRG-ALI: LSRG to ALI system (ALI query + response)

LSRG-E2: LSRG to ALI system (E2+, MLP, PAM location query)

#### **5.3.3.2 IP LSRG interfaces through IP signaling interfaces**

LSRG-LoST: LSRG to ECRF (LoST query and response)

LSRG-LIS: LSRG to LIS (SIP/held location de-reference)

LSRG-CIDB: LSRG to CIDB (http additional data de-reference)

LSRG-MCS: LSRG to MCS (http MSAG conversion service)

LSRG-SIP: LSRG to ESRP (SIP call)

LSRG-RTPPSAP: LSRG to PSAP (RTP for media)

LSRG-RTPUA: LSRG to UA (RTP for media)

#### **5.3.3.3 TDM LNG legacy interfaces**

LNG-SS7: LNG to EO/MS (SS7 call)

LNG-E2: LNG to MPC (E2+, MLP, PAM location query)

LNG-PROV: LNG to OSS (ALI SOI)

#### **5.3.3.4 IP LNG interfaces through IP signaling interfaces**

LNG-LoST: LNG to ECRF (LoST query and response)

LNG-Loc: PSAP to LNG (SIP/held location de-reference)

LNG-CIDB: LNG to CIDB (http additional data de-reference)

LNG-MCS: LNG to MCS (http MSAG conversion service)

LNG-SIP: LNG to ESRP (SIP call)

LNG-RTPPSAP: LNG to PSAP (RTP for media)

### **5.3.4 IP Origination<sup>5</sup>**

External NE-ESInet: NE-BCF (any external device to ESInet)

---

<sup>5</sup> Demarcation points associated with VoIP originations that are routed directly from functional elements in an i2-based VSP's network to i3 functional elements (i.e., the LNG) are a candidate for further study, as indicated in Section 8.3.

External ESInet-PSAP: BCF-BCF (any external ESInet to agency PSAP)

External UE-ESInet: UE-BCF (any external device to ESInet)

SIP Proxy-SIP: SIP Proxy to ESRP (SIP call)

LIS-Loc-PSAP: PSAP to LIS (location de-reference via SIP or HELD)

LIS-Loc-ESRP: ESRP to LIS (location de-reference via SIP or HELD)

### **5.3.5 Termination to Legacy PSAP via LPG**

#### **5.3.5.1 TDM legacy interfaces**

LPG-MF: LPG to Legacy PSAP (Traditional MF or Enhanced MF for call delivery)

LPG-ALI: PSAP to LPG (ALI query + response)

LPG-DTMF: PSAP to LPG (to support transfer requests)

#### **5.3.5.2 IP interfaces through IP signaling interfaces**

LPG-SIP: LPG to ESRP (SIP call)

LPG-LoST: LPG to ECRF (to support transfer requests)

LPG-CIDB: LPG to CIDB (http additional data de-reference)

LPG-MCS: LPG to MCS (http MSAG conversion service)

LPG-LIS: LPG to LIS (location de-reference via SIP or HELD)

LPG-LNG: LPG to LNG (location de-reference via SIP or HELD)

LPG-LSRG: LPG to (ingress) LSRG (location de-reference via SIP or HELD)

### **5.3.6 Location Validation**

LIS-LVF: LIS to LVF (LoST location validation)

i3 PSAP-LVF: i3 PSAP-LVF (LoST location validation)

### **5.3.7 ECRF/LVF Provisioning**

SIF-ECRF: SIF to ECRF (To support provisioning of ECRF)

SIF-LVF: SIF to LVF (To support provisioning of LVF)

## **6 Demarcation Associated with Legacy Gateways**

### **6.1.1 Demarcation for the LNG**

A Legacy Network Gateway (LNG) is a signaling and media gateway between legacy wireline/wireless originating networks and the NG9-1-1 provider's ESInet. Calls in legacy origination networks undergo conversion from TDM to IP formats for delivery into the ESInet. The

LNG attaches sufficient information to the call, such as location and callback number, for handling within ESInet.

There are two possible points of logical demarcation for the LNG illustrated in Figure 3:

- Between the originating carrier’s switch and the LNG (Demarcation A)
- Between the LNG and the ESRP (Demarcation B)

The LNG presents a unique case in NG9-1-1 demarcation, because the point of demarcation for this functional element has significant financial and regulatory impacts. Technical differences are summarized in the table below, but this document does not address the business and policy factors that will undoubtedly be among the drivers of any given solution.

The decision between whether the LNG is the responsibility of the originating carrier, or of the 9-1-1 Authority, will have a substantial impact on the overall network design and interconnection architecture. This decision will assign costs accordingly.

The defining difference between Demarcation A (TDM side of LNG) and B (IP side of LNG) is whether the originating carrier’s network connects to an IP interface or to a TDM interface. If the 9-1-1 Authority supplies the LNG, then the carrier must only connect its TDM trunks to that LNG. If the originating carrier provides the LNG, then the 9-1-1 Authority will accept IP traffic provided by the originating carrier. This distinction brings with it significant differences in the deployment and relative costs of transmission infrastructure committed to the NG9-1-1 network by either party.

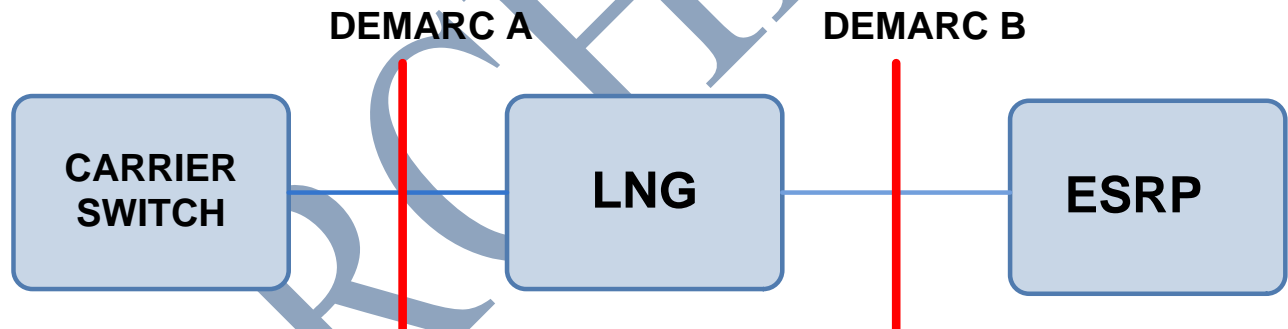

*Figure 3: LNG Demarcation Points*

The following table summarizes major technical issues associated with LNG demarcation options:

Attribute	Demarc A	Demarc B
LNG	Fewest <sup>6</sup> number of LNGs is one LNG per state or multi state group; most is one LNG	Fewest number of LNGs is one LNG per carrier; most is one LNG per NG911 provider

<sup>6</sup> In this table we do not consider redundancy/availability. Every LNG could be part of a redundant set of elements. While there would be other scenarios that generate more extreme conditions the table attempts to describe the most likely scenarios.

	per 9-1-1 authority	
TDM Transport	TDM trunks from ESGW or originating carrier switch to each LNG in the service area covered by the ESGW or switch	One trunk group per ESGW or originating carrier switch
SIP Transport	One SIP connection from LNG to ESRP (via a BCF)	SIP connections from LNG to each ESRP (via a BCF)
SS7 Transport	SS7 links to each LNG	SS7 managed within originating carrier
E2 links	E2 links to every LNG	Each originating carrier manages links internally
Protocol and Standard Variation	GR SS7 standards exist but new vendors may have SS7 qualification issues	NENA SIP based standards, no industry standard yet, SIP variation issues may complicate interface connection

## 6.2 Fundamental Differences Between Demarcation A and B

With Demarcation A, the demarcation point is on the originating carrier's side of the NG9-1-1 network, and the carrier connects its TDM trunks to the 9-1-1 Authority's TDM interface at the LNG. The 9-1-1 Authority is then responsible for call conversion from TDM to IP and delivery of the IP call to its NG9-1-1 network. With Demarcation B, the originating carrier is responsible for delivering a 9-1-1 call in an appropriate IP format to the NG9-1-1 network.

### 6.2.1 Quantity of LNGs

Depending on state and county 9-1-1 arrangements, Demarcation A may result in either a very small or very large number of LNGs. In those areas with a centralized 9-1-1 authority, such as a statewide authority, this option may provide for a single LNG per state or region. For those areas without a centralized 9-1-1 authority, such as within the scope of a county or city, this arrangement may require a separate LNG for each authority. These factors also depend upon the NG9-1-1 provider's network configuration and the service area(s) covered by the provider's ESInet. With Demarcation B, the number of LNGs scales with the originating carrier's infrastructure in the area. Depending on the structure of 9-1-1 Authorities in the region and the configuration of the serving NG9-1-1 network(s), Demarcation B may result in a smaller or greater number of LNGs than Demarcation A.

### 6.2.2 Transport

TDM trunking architecture is dependent on the number and placement of LNGs, and so, is also dependent on the structure of 9-1-1 Authorities and NG9-1-1 networks operating in the region. In Demarcation A, the longer transport facility supports TDM. In Demarcation B, the longer transport facility supports IP. Which option is preferable varies based on a number of factors, such as the architecture and number of NG9-1-1 providers operating in the region, number of LNGs, originating carriers operating in the region, geographic location of switching offices, architecture of legacy

TDM network(s), geographic location of BCF equipment, and/or geographic location of PSAPs. The fundamental concern is, given the inputs in a specific case, whether TDM transport or IP transport is most cost-effective and reliable.

There are transport facilities between the originating carrier's switch and the LNG as well as between the LNG and the SBC. As the number of switches is dependent on the number of originating carriers operating in the region, and the number of LNGs and SBCs is dependent on the number of 9-1-1 authorities operating in the region, the financial and operational advantages may rest on either Demarcation A or B depending on the region.

### 6.2.3 Protocol and Standard Variation

With Demarcation A, originating carriers deliver the same TDM traffic they deliver in a legacy environment; the LNG provides an interface that is analogous to a legacy Selective Router. With Demarcation B, the carrier delivers a SIP call to the ESRP via a BCF. While TDM protocols are well-established, there are some industry variations in SIP that may introduce additional complications in LNG-ESRP connectivity.

### 6.3 Demarcation of the LSRG

The LSRG will, in certain circumstances, provide needed functionality to facilitate emergency call handling during the transition period while the legacy emergency services network infrastructure migrates toward IP and PSAPs evolve to support full i3 functionality.

Based on the functional description provided below, the following demarcation points are associated with the LSRG:

- Between a Legacy SR that serves legacy origination networks and the LSRG
- Between the LSRG and Legacy SRs that serve PSAPs to which legacy or VoIP emergency call originations may be directed
- Between the LSRG and the BCF (on the ingress side as well as the egress side of the ESInet)
- Between the LSRG and the ALI database
- Between the LSRG and a Location Information Server (LIS) in an access network
- Between the LSRG and an ECRF
- Between a LSRG and a Call Information Database (CIDB)
- Between a LSRG and the MSAG Conversion Service (MCS).

Due to the close association between a legacy SR and a LSRG, it is expected that the LSRG will be the responsibility of the Emergency Services Network provider(s), in cooperation with the 9-1-1 Authority.

Specifically, the LSRG will provide needed functionality to support the following scenarios:

- Emergency call originations from legacy wireline and wireless callers, as well as VoIP emergency call originations that are routed via i2 Solution-based VoIP Service Provider (VSP) networks to a legacy SR, and are destined for an i3 PSAP that is served by an ESInet
- Emergency calls that originate in legacy wireline or wireless networks that are served by ESInets, and are destined for a PSAP that is served by a legacy SR

- Emergency calls that originate in i3-compliant originating networks that are served by ESInets, and are destined for a PSAP that is served by a legacy SR
- Emergency calls that are transferred between PSAPs served by legacy SRs and i3 PSAPs.

For the scenarios where the LSRG is handling emergency calls routed to it from legacy SRs or where it is routing emergency calls to legacy SRs, the LSRG is expected to provide SS7- SIP interworking functionality. This aspect of LSRG functionality is similar to what a Legacy Network Gateway provides for incoming calls from legacy wireline end offices and MSCs. However, the protocol interworking function at the Legacy Network Gateway is always from SS7 or MF signaling to SIP, whereas the LSRG is expected to provide SS7-to-SIP interworking as well as SIP-to-SS7 interworking. This is because the Legacy Network Gateway is only expected to support emergency call originations from wireline end offices and MSCs that flow toward an i3 PSAP, whereas the LSRG must support emergency call originations that flow from legacy SRs toward i3 PSAPs, as well as emergency call originations that are routed via an ESInet to a PSAP that is served by a legacy SR.

Functionality must also be applied by a LSRG to emergency calls that are routed between ESInets and SRs to allow the information provided in call setup signaling to be used to support routing to the correct destination PSAP for the call. For emergency calls incoming to the ESInet from a legacy SR, this means making an association between a 10-digit key received in incoming signaling and location information that can be used by an i3 ECRF to identify the Route URI for the call. Once again, this is similar to functionality provided by a Legacy Network Gateway, although the mechanisms for retrieving the location information associated with the 10-digit key are different. For emergency call originations that are routed to the LSGR via a legacy SR, the LSRG will query an ALI database to obtain caller location information using a 10-digit key received in incoming signaling from the SR.

For emergency calls delivered by the ESInet to a legacy SR, the LSGR must create a 10-digit pseudo-Automatic Number Identification (pANI) associated with the location information received in incoming SIP signaling, and pass it in SS7 signaling to the SR for delivery to a legacy PSAP. The creation of a 10-digit pANI and the association of the pANI with location information received in incoming SIP signaling is functionality that is also provided by a Legacy PSAP Gateway. However, the Legacy PSAP Gateway uses this information to populate traditional MF or Enhanced MF signaling to a legacy PSAP, whereas the LSRG will populate this information in outgoing SS7 signaling to a legacy SR. The legacy SR delivers the pANI to the legacy PSAP and the legacy PSAP uses the pANI to query an ALI database. The ALI database will generate an E2+ (or PAM) query to the LSGR to request location information.

In addition, the LSRG must also support SIP and HTTP-Enabled Location Delivery (HELD) mechanisms for de-referencing location references that may have been included in an INVITE message from an ESRP. The LSRG must also be capable of querying a Call Information Database (CIDB) for “Additional Data Associated with a Call” in order to allow it to fully populate responses to ALI databases.

#### 6.4 Demarcation for the LPG

Based on the functional description provided below, the following demarcation points are associated with LPG:

- Between the LPG and an ESRP (via a BCF) in the i3 ESInet
- Between the LPG and the legacy PSAPs to which legacy or VoIP emergency call originations may be directed and from which transfer and ALI requests may be received
- Between the LPG and a LIS in an access network (for location de-referencing)
- Between the LPG and a LNG (for location de-referencing)
- Between the LPG and a LSRG (for location de-referencing)
- Between the LPG and an ECRF
- Between a LPG and a CIDB
- Between a LPG and the MSAG Conversion Service (MCS).

Due to the role of the LPG in presenting calls routed via an i3 ESInet to legacy PSAPs in a manner that is expected by the legacy PSAP, it is expected that the LPG will be the responsibility of the NG9-1-1 network provider, in cooperation with the 9-1-1 Authority.

The LPG is an i3 functional element that supports the interconnection of the ESInet with legacy PSAPs. It plays a role in the delivery of emergency calls that traverse an i3 ESInet to get to a legacy PSAP, as well as in the transfer and alternate routing of emergency calls between legacy PSAPs and i3 PSAPs. The Legacy PSAP Gateway supports an interface towards the ESInet on one side, and a traditional MF or Enhanced MF interface (comparable to the interface between a traditional Selective Router and a legacy PSAP) on the other side for call delivery. The LPG also includes an ALI interface (as defined in NENA 04-001 or NENA 04-005) which can accept an ALI query from the legacy PSAP, and respond with location information that is formatted according to the ALI interface supported by the PSAP. If an emergency call routed via the ESInet contains a location reference, the LPG must support a de-referencing interface to a LIS or LNG or ingress LSRG to obtain the location information that will be returned to the legacy PSAP in the ALI response. To populate non-location information in the ALI response, the LPG may need to support an interface to a CIDB. The LPG may also support an interface to an ECRF which it can use to determine the transfer-to party under certain Selective Transfer scenarios.

The LPG is expected to provide special processing of the information received in incoming call setup signaling to facilitate call delivery to the legacy PSAP, to assist legacy PSAPs in obtaining callback and location information, and to support feature functionality that is currently available to legacy PSAPs, such as call transfer and requests for alternate routing.

Traditional MF and E-MF interfaces to legacy PSAPs assume that callback information signaled to a PSAP will be in the form of a 10-digit North American Numbering Plan (NANP) number. There are specific substitute number strings defined for use in scenarios where the callback number is either missing or garbled. It is possible that VoIP emergency call originations will contain callback information that is not in the form of (or easily converted to) a 10-digit NANP number. To address this situation, the LPG will perform a mapping from the non-NANP callback information to a

locally-significant digit string (i.e., a pseudo Automatic Number Identification [pANI]) that can be delivered to the legacy PSAP via traditional MF or E-MF signaling.

Likewise, location information associated with VoIP emergency call originations is expected to be in the form of a civic address or geodetic coordinates, rather than a NANP number. The LPG will therefore be expected to map this information to a location key (i.e., pANI) that is in the form of a NANP number so that it can be delivered to legacy PSAPs with interfaces that support the delivery of location information.

Whether a legacy PSAP supports a traditional MF interface or an E-MF interface, it is possible for the ANI information which appears on the PSAP CPE display to “flash” if the call has first been default-routed or alternate-routed. In a legacy E9-1-1 environment, the decision about whether or not to flash the display at the PSAP depends upon local administration of Emergency Service Number (ESN) information. The setting of the flashing indication will depend on the particular ESN used to point the call to the PSAP.

In the context of the i3 architecture, the ESRP interacts with a Policy Routing Function to identify alternate routing addresses based on policy information associated with the next hop in the signaling path. The ESRP uses the SIP History-Info header, described in IETF RFC 4244, and the associated Reason header, described in IETF RFC 3326 to signal forward an indication that alternate/default routing has been applied to an emergency call so that the LPG can determine how to set the Special Handling indication in the MF signaling it sends to the PSAP. The LPG will determine the appropriate coding of the Special Handling indication sent to the PSAP (in the Numbering Plan Digit or ANI II digits) based on the content of the received History-Info and Reason headers and provisioned data associated with the destination PSAP.

When a legacy PSAP determines that it is necessary to transfer an emergency call, it sends a “flash” signal and waits for dial tone. Once the dial tone is received, the PSAP requests the transfer either by operating a key associated with a particular type of secondary PSAP (e.g., fire department) or a particular PSAP destination (e.g., using a speed calling feature), or by manually dialing the number of the desired destination.

When the LPG receives a flash indication from the legacy PSAP, it will interpret it as a request to initiate a call transfer. Upon subsequently receiving a “\*XX” code, a string of “# + 4 digits,” or a 7/10-digit directory number the LPG will request that a conference be created. When the call to the secondary PSAP is answered, and the primary PSAP determines that it should drop off the conference and complete the transfer, it will disconnect from the call by sending an on-hook signal to the LPG. The LPG will then send a BYE message to the conference bridge to terminate the session with the conference bridge.

## 7 Recommended Reading and References

1. NENA 08-003
2. NENA 77-501
3. J-STD 036

4. Letter from Thomas J. Sugrue, Chief, Wireless Telecommunications Bureau, Federal Communications Commission, to Marlys R. Davis, E911 Program Manager, King County E-911 Program Office, Department of Information and Administrative Services, dated May 7, 2001.

## **8 Recommended Reading and References**

None

## **9 Exhibits**

None

## **10 Appendix**

None.

## **11 Previous Acknowledgments**

None. This is original document.

ARCHIVED