

Firestopping

Plastic Pipe in Fire Resistive Construction

By
Eva Ackerman, RectorSeal
Yanwei Cen, RectorSeal
Carl McGinnis, RectorSeal

PPFA
Plastic Pipe and Fittings Association

Table of Contents

Introduction 3

Important Notice 4

Glossary..... 5

Firestopping Questions and Answers 12

Tests: ASTM E119, ASTM E814 and UL 1479 13

Piping Materials, ASTM Standards & Piping Systems..... 14

Testing a Firestop System 15

Firestopping in Three Steps..... 18

Typical Installation Procedures 19

Examples of Typical Listings..... 20

Introduction

The material in this manual has been assembled by the Plastic Pipe and Fittings Association and is published as a guide for proper firestopping of plastic pipe penetrations in fire resistive construction. Its purpose is to provide builders, engineers, architects, and mechanical-plumbing contractors information about the materials and products used in firestopping plastic piping. It also provides some general information about the proper installation of those materials and products.

A variety of devices, materials and products used individually or in combination with one another are used in firestops. These firestops have been developed for plastic piping penetrations of fire rated barriers so that the fire rating of the barrier is maintained. Installers must carefully follow the manufacturer's instructions when using their materials, products or devices.

New plastic piping materials are constantly being developed. Also new firestopping materials and devices are being developed and tested. In addition, the construction industry is being encouraged to adopt new technology for building fire protection. Current information is available on the websites listed at the back of this manual.

The evaluation of walls, floors and floor/ceiling assemblies to determine their fire resistance rating is done by subjecting large-scale assemblies to fires that produce established time/temperature conditions in a large furnace. The tests are done in accordance with ASTM E119, Standard Test Methods for Fire Tests of Building Construction and Materials. The results of these tests provide the Fire Resistance Ratings that are expressed in terms of hours. Building codes, in turn, require certain barriers to have minimum fire resistance ratings. The hourly rating depends on the building size, height and occupancy plus other factors.

There are a great many wall designs. However, no matter what wall design is used, the primary question concerning a firestop for a plastic pipe penetrating a rated barrier is always which materials when used in conjunction with which plastic pipe firestop design will achieve a one-, two- or three-hour rating that is needed to match (or exceed) the rating of the barrier.

Important Notice

The statements, descriptions, drawings, and other materials in this manual are informational only and should not be construed as and are not intended to be an endorsement of any product, system or application. No warranty or representation is made to the fitness of any product or system for a particular purpose or to the suitability of any product or system for a specific application.

Glossary

ABS Pipe - Acrylonitrile-Butadiene-Styrene pipe - a plastic pipe used for drains, waste, and vent systems and sewer.

Annulus or Annuli - The gap between the penetrating item and the outside edge of the hole.

ASTM - American Society for Testing and Materials; an independent consensus standards generating organization composed of volunteers.

Backer Rod - A cylindrical polyurethane or polyethylene foam material used to provide support and set the proper depth of material for gunned or troweled in place sealant.

Backing Material - Combustible or noncombustible material used to provide support for gunned, sprayed or troweled in place sealant or caulk.

Char - A grayish black, crusty material formed by burning organic type sealants.

Classification - A series of procedures, usually administered by an independent testing laboratory, by which the consumer is protected and assured that the product which was tested is the same as the product purchased.

Closed System - A piping system which is sealed, typically carrying fluids under pressure, such as hot and cold water distribution. The exact definition on a closed pipe system is determined by the local authority having jurisdiction. For instance, electrical conduit in a vertical orientation through a roof installation may be considered a vented system and the same conduit in a horizontal orientation or penetrating through a floor may be considered closed.

CMU - Concrete Masonry Unit, such as concrete block used to construct walls. Usually hollow.

Cohesion - The molecular attraction that holds the body of a sealant or adhesive together. The internal strength of an adhesive or sealant.

Cohesive Failure - Failure characterized by rupture within the sealant, adhesive, or coating.

Collar - A galvanized sheet metal restricting device used in conjunction with plastic pipe. Its function is to direct and control the intumescent action of the firestopping material.

Compatibility - The capability of two or more materials when placed in contact or close proximity with one another to maintain their usual physical or chemical properties, or both.

Concentric - Having a common center; a pipe centered in the middle of a through-penetration hole results in a concentric annulus.

CPVC Pipe - Chlorinated Polyvinyl Chloride pipe - a grade of plastic pipe commonly used for hot/cold water distribution, sprinkler piping, and some chemicals. Suitable for high temperatures.

Cure - In sealants, the process by which a compound attains its intended properties through evaporation, chemical reaction, heat, radiation or combinations thereof.

DWV Pipe - Non-pressure (vented) piping used for Drain, Waste & Vent (sanitary waste) systems.

Eccentric - Off center; an eccentric annulus results when a pipe is not centered in the hole.

Elasticity - The ability of a material to return to its original shape after removal of a load.

Elastomer - A macromolecular material that returns rapidly to approximately the initial dimensions and shape after substantial deformation by a weak stress and release of the stress.

Elongation - Extension produced by a tensile stress.

Endothermic - A process or change that takes place with absorption of heat and requires high temperature for initiation and maintenance.

F Rating - A firestop shall be considered as meeting the requirements for an F rating when it remains in the opening during the fire test and hose stream test within the following limitations: The firestop shall have withstood the fire test for the rating period without permitting the passage of flame through openings, or the occurrence of flaming on any element of the unexposed side of the firestop. During the hose stream test, the firestop shall not develop any opening that would permit a projection of water from the stream beyond the unexposed side. (ASTM E814)

Fire Endurance - A measure of the elapsed time during which a material or assembly continues to exhibit fire resistance under specified conditions of test and performance. As applied to elements of buildings, it shall be measured by the methods and the criteria defined in ASTM E119 Fire Tests of Building Construction and Materials.

Fire Rated or Fire Resistance - A system which has been tested by a qualified laboratory in accordance with the appropriate ASTM test standard and has met the mechanical and endurance requirements of that standard. The property of a material or assembly to withstand fire or give protection from it. As applied to elements of buildings, it is characterized by the ability to confine a fire or to continue to perform a given structural

function, or both. Systems are rated for 1, 2, 3 or 4 hours, based on the results of the fire test.

Fire Resistance Classification - A standard rating of fire-resistance and protective characteristics of a building construction or assembly. (ASTM E119)

Firestop - A through-penetration firestop is a specific combination of components or materials that fill the opening around wall, floor or ceiling penetrating pipes and their means of support for the purpose of preventing the spread of fire. (ASTM E814)

Fire Test Standard - Fire test standards are procedures intended to measure and describe the response of materials, products, and systems to sources of heat or flame under controlled conditions. These tests are intended to provide information useful for such purposes as product development, quality control, and specification description. They are not intended to be used alone to provide a measure of the fire hazard of materials, products or systems. One or more fire test standards, however, may be used as part of a fire hazard standard. Fire test standards are separate and distinct from fire hazard standards, which are used to describe, measure, assess or control the behavior of materials, products and systems in the relevant environment.

FM – Factory Mutual Research; a testing laboratory.

Intumesce - To swell, enlarge, inflate or expand, as with heat. Intumescent firestopping sealants swell to close gaps or voids in through-penetration openings when exposed to high heat conditions.

ITS – Intertek Testing Services, a testing laboratory.

L Rating - The optional L-rating criteria determines the amount of air leakage, in cubic feet per minute per square foot of opening (CFM/sq ft) or in cubic feet per minute per unit (CFM/unit) for fixed-size opening units, through the firestop system at ambient and/or 400°F air temperatures at an air pressure differential of 0.30 in. W.C. The L ratings are intended to assist code officials and others in determining the firestop systems suitability of restricting the movement of smoke in accordance with ANSI/NFPA 101, "Life Safety Code".

Mineral Fiber - A noncombustible insulation material made from mineral fibers. It is also known as mineral wool or safing material. It is typically used as a backing and filler material in through-penetrations.

Modulus - The ratio of stress to strain. Also the tensile strength at a given elongation.

Material Safety Data Sheet (MSDS) - A document required by law describing the health and safety aspects of a material as it pertains to its properties, health effects, hazards, handling and disposal.

Nominal Pipe Size (NPS) – A term used in pipe and fitting standards and by the trades to

refer to the approximate inside diameter for a pipe regardless of pipe wall thickness.

Non-Sag Sealant - A compound that exhibits little or no flow when applied in vertical or inverted joints.

Open System - An open system or sometimes referred to as a vented system is a piping system which allows air flow to the exterior of the building to prevent back flow or vacuum, i.e.: DWV pipe system (Drain, Waste or Vent or roof drains). The exact definition on an open piping system is determined by the local authority having jurisdiction. For instance, electrical conduit in a vertical orientation through a roof installation may be considered a vented system and the same conduit in a horizontal orientation or penetrating through a floor may be considered as a closed system.

PE Pipe - Polyethylene pipe; a plastic pipe that is typically used for gas distribution. It is a material that melts when exposed to heat.

PE-RT – Raised temperature polyethylene pipe; a plastic pipe used for hot and cold water distribution or hydronics.

PEX – Crosslinked polyethylene pipe; a plastic pipe used for hot and cold water distribution or hydronics.

PP Pipe - Polypropylene pipe; a plastic pipe that is suitable for higher temperature applications and is typically used for hot and cold water distribution and some chemical services. It is a material that melts when exposed to heat.

Pressure System – see Closed System

PVC Pipe - Polyvinyl Chloride Pipe - a common plastic pipe used for cold water distribution in both pressure (closed) or vented (DWV) applications. It is a material that softens and deforms when exposed to heat.

Sealant - A material that has the adhesive and cohesive properties to form a seal.

Sealant Backing - A compressible material placed in a joint before applying a sealant.

Self-Leveling Sealant - A compound that exhibits flow sufficient to seek gravitational leveling.

Shelf Life - The maximum time packaged materials can be stored under specified conditions and still meet the performance requirements specified.

Shrinkage - A decrease in length, area or volume.

SRI – Southwest Research Institute; a testing laboratory.

Standard Time/Temperature Curve - A graphical representation derived from

prescribed time-temperature relationships and used to control burn test furnace temperatures with progressing time.

Steel Sleeve - A form used when pouring concrete to provide space for a penetrating item. Also may be used inside hollow construction walls to prevent firestopping materials from entering wall cavities unnecessarily.

Structural Sealant - A sealant capable of transferring dynamic or static ("live" and/or "dead") loads, or both, across joint members exposed to service environments typical for the structure involved.

Substrate - A material upon which films, treatments, adhesives, sealants, membranes, and coatings are applied.

System Number - A number assigned to a specific detail or series of similar details which are then indexed in numerical order in a reference book or directory.

Tensile Strength - Resistance of a material to a tensile force (stretch). The cohesive strength of a material expressed in psi.

Tooling - The act of compacting and contouring a sealant in a joint.

Tooling Time - The time interval after application of a one-component sealant or after mixing and application of multi-component sealant during which tooling is possible.

T Rating - A firestop shall be considered as meeting the requirements for a T rating when it remains in the opening during the fire test and hose stream test within the following limitations: The transmission of heat through the fires during the rating period shall not have been such as to raise the temperature of any thermocouple on the unexposed surface of the fires or on any penetrating item more than 325°F above its initial temperature. Also, the firestop shall have withstood the fire test for the rating period without permitting the passage of flame through openings, or the occurrence of flaming on any element of the unexposed side of the fires. During the hose stream test, the firestop shall not develop any opening that would permit a projection of water from the stream beyond the unexposed side. (ASTM E814)

Through Penetration - Consists of three items: 1) wall or floor construction 2) penetrating item or absence thereof 3) the hole or void.

UL - Underwriters Laboratories Incorporated; an independent testing laboratory.

Vented System— see Open System

W Rating - The optional W rating determines the capability of the firestop system to maintain watertightness of the penetration through a floor or wall construction at ambient air conditions under 3 ft of water pressure head (1.3 psi) for a period of 72 hours. The W rating is intended to assist code officials and others in determining the suitability of firestop

systems in applications where submersion in water may be a factor.

Wire Mesh - Galvanized steel hardware cloth used to support backing material in gypsum wallboard and hollow concrete block construction.

Working ("pot") Life - The time interval after opening a container of a single component sealant or after mixing the components of a multi-component sealant, during which application and tooling is possible.

Firestops – Firestop Systems – Fire Stops

ASTM E814 defines firestops as follows: “*firestop* – a through-penetration fire stop is a specific construction consisting of the materials that fill the opening around penetrating pipes and their means of support through the wall or floor opening to prevent spread of fire.”

The UL Fire Resistance Directory states: “A firestop is a specific construction consisting of a wall or floor assembly, a penetrating item passing through an opening in the wall or floor assembly, and the materials designed to prevent the spread of fire through the opening.” In the directory, each page has the heading THROUGH PENETRATION FIRESTOP SYSTEMS, but listings are identified only as System No XXXXX.

These three terms, Firestops – Firestop Systems – Fire Stops, are used interchangeably in this manual.

Before doing any firestopping, the installer should obtain approval from the building inspector, the Code Official, or the project engineer. All firestops must pass ASTM E814 (or UL 1479) tests and be listed by an approved agency. A firestop can consist of a device, several components or materials used in a specific way in order to meet the hourly rating needed. Individual components or materials are not assigned ratings. Modifying a listed firestop by substitution or elimination of specific components is not permitted unless stated in the listing.

Some attributes of the F and T rating of a firestop system are:

- Pipe material, pipe size or pipe wall thickness;
- Wall material, e.g., concrete block, wood or steel framed gypsum board
- Wall thickness, wall rating (hours)
- Floor slab thickness, fire rating (hours)
- Floor/ceiling materials/thickness, fire rating (hours)

Caution: Some firestop sealants may contain chemical additives that can cause damage to plastic pipe. Only compatible fire stop materials should be used. Contact the firestop and pipe manufacturer to confirm chemical compatibility of any sealants that may be used with the piping material prior to use.

Firestopping Questions and Answers

Q: Why is a firestop needed?

A: Firestops are required by all building codes whenever fire barriers (walls or floors) are penetrated. Firestops can play a significant role in controlling the spread of fire and smoke.

Q: What is a plastic pipe firestop?

A: It is a device, a material or a combination of materials used to fill or seal a pipe penetration so that the fire integrity of the rated barrier (wall or floor) is maintained whenever it is penetrated by the plastic pipe.

Q: How are plastic pipe firestops tested to verify their performance?

A: This is done by building a section of wall, floor, or floor/ceiling assembly with the plastic pipe and firestop in place. The complete unit is subjected to a fire test that meets the requirements of ASTM E814 (or UL 1479). In order to qualify as a “listed” or “classified” firestop, it must resist the passage of flame and temperature for the prescribed time period that equals the barrier rating in “hours.” Note: Some codes prescribe only an “F” rating and no “T” rating.

Q: How do firestops work?

A: They fill and/or cover the annular space around pipes penetrating walls and floors. Most firestops contain materials that intumesce (expand) in the presence of heat. This action seals the penetration if heat softens the pipe.

Q: What information is needed to select an acceptable firestop?

A: Type of barrier, wall or floor; its material, its thickness, and its fire rating in hours. The pipe material; size of pipe; schedule or series of pipe that indicates wall thickness. The size of the hole and the annular space. The pipe’s position in the hole (centered or off-center). Verify that the firestop material is chemically compatible with the piping material.

Q: How can firestopping be done to meet code requirements?

A: Gather all the necessary information. Select a listed firestop. Get the right product, and carefully follow all the installation instructions.

Q: Will the firestopping serve as a pipe support?

A: No. All codes call for proper support of piping and give some support spacing. They make no reference to the firestop as a portion of the support.

Tests for Fire-rated Barriers & Firestops

ASTM E119

Standard Test Methods for Fire Tests of Building Construction and Materials (ASTM E119) was first published in 1917. This method is intended to evaluate the duration for which the types of assemblies will contain a fire or retain their structural integrity or both during a predetermined fire test exposure. The test exposes a specimen to a *standard fire* that is controlled to achieve specified temperatures over a specified time period. In some instances the *fire exposure* may be followed by a standard *fire hose stream*. The results of a Fire Endurance Test plus a Hose Stream Test provide a “fire rating” for a barrier (wall or floor) expressed in hours. If a firestop is to be tested using an E119 wall or floor, the test specimen must meet the minimum E119 dimension requirements – 100-sq. ft. for a wall or 180-sq. ft. for a floor. Since such large-scale tests are expensive, *several firestops* can be tested in a single assembly. When conducting such a test, some of the firestops may pass the test while others may fail.

ASTM E814

The Standard Test Method for Fire Tests of Through-Penetration Fire Stops (ASTM E814) was first published in 1981. This method is used to evaluate fire stops that are intended for use in openings in fire-resistive walls and floors that have been evaluated in accordance with test method E119. The E814 test method utilizes a smaller wall or floor unit with the penetrating item and the firestop in place. The same *fire exposure* and *specified standard fire hose stream* tests used for the E119 test are applied to the E814 assembly. The E814 test method is less costly because a smaller furnace can be used and smaller wall or floor units are used.

Hose Stream Test

The hose stream test is conducted on a wall or floor unit with a firestop mounted on it immediately after the unit has been subjected to a fire-exposure test for a period equal to one half that indicated as the resistance period in the fire test. The maximum fire-exposure test shall be not more than 60 minutes. During the hose stream test, the firestop shall not develop any opening that would permit a projection of water from the stream beyond the unexposed side.

UL 1479

Underwriters Laboratories standard UL 1479, Fire Tests of Through-Penetration Firestops, is similar to ASTM standard E814, with a few exceptions. UL 1479 requires environmental exposures of intumescent fill, void or cavity materials. Samples of the material are exposed to accelerated aging and high humidity. To simulate aged material, it is exposed to 158 degrees F for 270 days. To simulate high humidity, samples are exposed to a minimum of 97% humidity at 95 degrees F for a period of 180 days. Then the samples are subjected to an expansion ratio and expansion pressure test. The expansion pressure test measures the pressure that the sample exerts during its’ intumescence or expansion when heated. Comparisons of the pressures are then made between a “new” sample and an “aged” or high humidity sample.

Piping Materials, ASTM Standards and Piping Systems

The table shows various plastic materials, the ASTM Standards for the various pipe and fitting products used in piping systems within buildings. Sanitary waste (DWV Drain, Waste and Vent), roof drains, condensate drain plus (hot & cold) water distribution systems are common to all buildings. There are several materials made to different

ASTM Standards used for each of these piping systems. It is important to understand that different products may require different firestop systems.

Firestopping for all types of piping systems must be selected on the basis of all the pertinent variables.

Material	ASTM Standards	Application
ABS	D2661 and D1527	DWV Roof Drain
ABS Foam Core	F628	DWV Roof Drain
CPVC	D2846 F441 and F442	Hot and Cold water distribution Fire sprinklers Corrosive Wastes Condensate Drains Vents-High Efficiency (90%) Furnaces
PE	D2737	Cold water
PE-RT	F2769 and F2623	Hot and Cold Water distribution and hydronics
PP	F1412	Chemical waste
PEX	F876	Hot and Cold water distribution Hydronic Heating
PVC	D1785 and D2241	Chilled Water Low Temperature Heating/Cooling Deionized Water Vents-High Efficiency (90%) Furnaces
PVC	D2665 and D2949	DWV Roof Drains Condensate Drains
PVC Foam Core	F891	DWV Roof Drains

Testing a Firestop System

A through – penetration firestop system is comprised of four parts:

- Fire-rated barrier (floor, wall or floor/ceiling)
- The hole or opening
- The pipe passing through the barrier
- The firestop (device, product or combination of materials)

The barrier may be a wood or metal stud gypsum board wall, a block wall, a concrete floor slab, or a wood floor/ceiling assembly. The thickness of each barrier and the burning characteristics of each material are different so separate tests must be performed with each firestop system. To test a firestop, a section of a barrier with a plastic pipe passing through a hole that is sealed with the firestop is placed in a furnace. Then the fire can be applied to one side while the other side is at normal conditions. During the test, the plastic pipe in the assembly is monitored for time of flame through (if it occurs) and for temperature rise. After the fire test, the assembly is removed from the furnace and subjected to the hose stream applied from the hot side to see if it can withstand that force without a visible water stream coming through. This test provides the F rating and T rating values for that firestop (in hours) if the hose stream requirement is met. In ASTM E814, we find the following Rating Criteria:

F Rating

A firestop shall be considered as meeting the requirements for an F rating when it remains in the opening during the fire test and hose stream test within the following limitations:

“The fire stops shall have withstood the fire test for the rating period without permitting the passage of flame through the openings, or the occurrence of flaming on any element of the unexposed side of the firestops.”

“During the hose stream test, the fire stop shall not develop any opening that would permit a projection of water from the stream beyond the unexposed side.” (ASTM E814)

T Rating

A firestop shall be considered as meeting the requirements for a T rating when it remains in the opening during the fire test and hose stream test with the following limitations:

“The transmission of heat through the firestop during the rating period shall not have been such as to raise the temperature of any thermocouple on the unexposed surface of the firestop or on any penetrating item more than 325°F above its initial temperature”. Also, the firestop shall have withstood the fire test for the rating period without permitting the passage of flame through openings, or the occurrence of flaming on any element of the unexposed side of the firestops.

One reason a T rating is important is that heat can transfer through a penetrating item during a fire to the other side of a rated floor assembly. Heat transfer can have the same detrimental effect as flames.

The relationship between F ratings and T ratings is that although every tested system has F and T ratings, they are not always equal. It is difficult to achieve T ratings for penetrating items that transfer heat readily, such as uninsulated metallic pipes. If the temperature rise exceeds 325 degrees F, it is possible for materials to combust that come in contact with the heated penetrating item. This combustion may allow the transfer of fire to the floor above without flames ever leaving the area of the fire’s origin.

L Rating

The optional L-rating criteria determines the amount of air leakage, in cubic feet per minute per square foot of opening (CFM/sq ft) or in cubic feet per minute per unit (CFM/unit) for fixed-size opening units, through the firestop system at ambient and/or 400°F air temperatures at a pressure differential of 0.30 in. W.C. The L ratings are intended to assist code officials and others in determining the firestop systems suitability of restricting the movement of smoke in accordance with ANSI/NFPA 101, "Life Safety Code."

W Rating

The optional W rating determines the capability of the firestop system to maintain watertightness of the penetration through a floor or wall construction at ambient air conditions under 3 ft of water pressure head (1.3 psi) for a period of 72 hours. The W rating is intended to assist code officials and others in determining the suitability of firestop systems in applications in which submersion in water may be a factor.

Hose Stream

Subject a duplicate specimen to the fire-exposure test for a period equal to one half of that indicated as the resistance period in the fire test, but shall be not more than 60 minutes, immediately after which subject the specimen to the impact, erosion, and cooling effects of a hose stream as described in Table 2 (below) directed first at the middle and then at all parts of the exposed face, with changes in direction being made slowly.” (ASTM E814)

Pressure and Duration – Hose Stream Test

Resistance Rating, minutes	Water pressure at base of nozzle, PSI	Duration of application per exposed area, s/ft ²
Rating ≥ 240	45	3.0
120 ≤ Rating ≤ 240	30	1.5
90 ≤ Rating ≤ 120	30	0.90
60 ≤ Rating ≤ 60	30	0.60
Rating ≤ 60 if desired	30	0.60

“During the Hose Stream Test, the fire stop shall not develop any opening that would permit a projection of water from the stream beyond the unexposed side.” (ASTM E814)

Testing Facilities and Listing Agencies

There are many laboratories that conduct ASTM fire testing. Many also provide listing services. Following are a few that provide both services:

Factory Mutual Research (FM)
Intertek Testing Services (ITS) (formerly Warnock Hersey (WH))
Southwest Research Institute (SRI)
Underwriter’s Laboratories (UL)

Firestopping in Three Steps

STEP ONE

Gather all the needed information

1. Type of wall, floor or floor/ceiling (wood or steel stud, concrete, gypsum).
2. Fire rating of the barrier.
3. Pipe material (ABS, PVC, CPVC, and PEX).
4. Pipe size and wall thickness (Schedule or SDR).
5. Diameter of the hole (inches).
6. Annular space = hole diameter – pipe OD/2.
7. Check with local Code Official to see who inspects installed firestop.

STEP TWO

Find corresponding listing with drawing

1. Locate a directory of listed firestop systems, e.g., the UL Fire Resistance Directory; or Intertek WH and OPL Mark Directory.
2. Identify all listed firestop systems based upon information in STEP ONE. Select the system that is most suitable for your conditions, taking into account all the variables. Verify that the firestop material is chemically compatible with the piping material.
3. Obtain all the materials, products or the device needed, plus the installation drawings and instructions.

STEP THREE

Apply product according to the drawing and listing details, and manufacturer's instructions.

1. Make sure the information in the Listing and the Installation Drawing and/or manufacturers instructions do not conflict, e.g., type and size of pipe, annular space, etc.
2. Follow the instructions provided in the installation drawing.
3. Check to see whether the annular space seal is needed on both sides of the barrier.

Typical Installation Procedures

General Installation Information

1. All surfaces to which the firestop product is to be applied should be free of dirt and debris.
2. The penetrating pipes should be properly supported on both sides of the wall or floor. Generally firestop systems provide no support for the pipes.
3. If on-site through-penetration conditions differ from those shown on the installation instructions, contact the manufacturer of the firestop before beginning installation.
4. Carefully follow manufacturer's instructions for the installation of the firestop.

EXAMPLE FIRESTOP SYSTEMS
Plastic pipe through gypsum wall with caulk

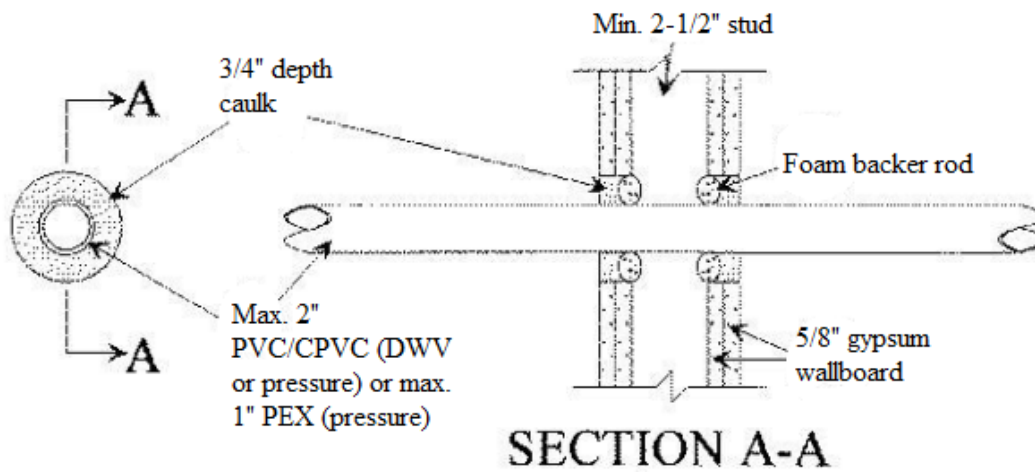

System Configuration Information																
Product(s)			Penetrating Item(s)			Hole Size	Annular Spacing			Additional Installation Materials and Aids			Backing Material		ASTM E814 Rating	
Fill Mat'l	Min. Thick.	Other	Type	Size	Insulation	Max.	Min.	Max.	Wire Mesh	Steel Sleeve	Other	Type	Depth	T	F	
Caulk	3/4" both sides	None	PVC, CPVC, SCH40 closed/open	Up to 1"	None	3-5/8"	5/8"	5/8"	None	None	None	Foam backer rod	N/A	1-1/2	2	
			PEX SDR 9	Up to 1"												

INSTALLATION INSTRUCTIONS

These instructions are for the installation of through-penetration fire stop system in a minimum 3.5" thick steel or wood stud fire rated gypsum wallboard as listed by Underwriter's Laboratories Inc. Refer to above drawings and System Configuration Information for component details.

1. Clean all hole, pipe and insulation surfaces in penetration area to remove loose debris, dirt, oil, wax, grease, old caulking, etc.
2. Install backing material by firmly packing annular space with foam backer rod from both sides of wall. Recess backing material at least 3/4" in from both sides of wall to accommodate the required fill depth of caulk.
3. Gun, trowel, and/or pump fire stopping sealant to minimum 3/4" depth on both sides of wall. Trowel sealant surfaces flush with wall surfaces and to a smooth defect-free finish.

Plastic pipe through wood floor with caulk

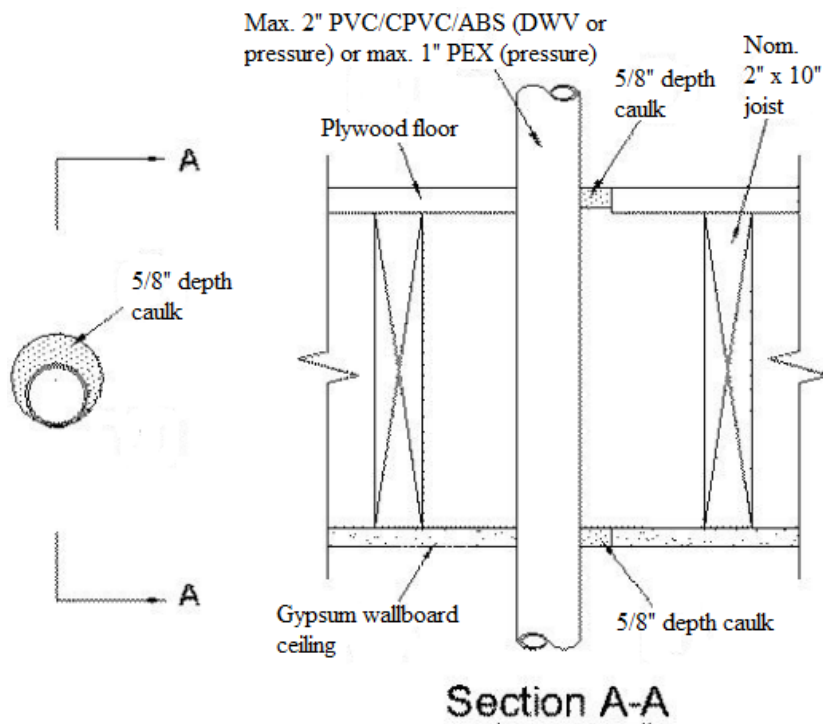

System Configuration Information																
Product(s)			Penetrating Item(s)			Hole Size	Annular Spacing			Additional Installation Materials and Aids			Backing Material		ASTM E814 Rating	
Fill Mat'l	Min. Thick.	Other	Type	Size	Insulation	Max.	Min.	Max.	Wire Mesh	Steel Sleeve	Other	Type	Depth	T	F	
Caulk	5/8"	None	PVC, CPVC, ABS closed/open	Up to 2"	None	3"	0"	5/8"	None	None	None	None	N/A	1	1	
			PEX	Up to 1"												

INSTALLATION INSTRUCTIONS

These instructions are for the installation of through penetration fire stop system in 1 hour fire rated solid or trussed lumber joist floor-ceiling assembly. Refer to above drawings and System Configuration Information for component details.

1. Clean all hole, pipe, and insulation surfaces in penetration area to remove loose debris, dirt, oil, wax, grease, old caulking, etc.
2. Gun, trowel, and/or pump firestopping sealant to a minimum 5/8" depth in annular space of floor and ceiling. Trowel sealant surfaces flush with ceiling and floor surfaces and to a smooth defect-free finish.

Plastic pipe through gypsum wall with caulk

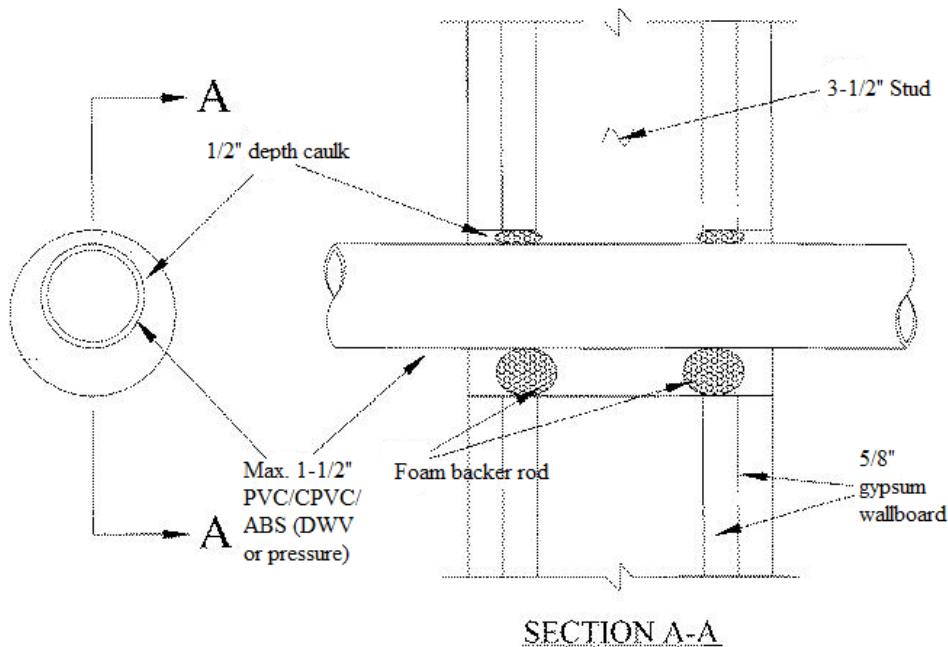

ASTM E814 Rating																
System Configuration Information																
Product(s)			Penetrating Item(s)			Hole Size	Annular Spacing			Additional Installation Materials and Aids			Backing Material			
Fill Mat'l	Min. Thick.	Other	Type	Size	Insulation	Max.	Min.	Max.	Wire Mesh	Steel Sleeve	Other	Type	Depth	T	F	
Caulk	1/2"	None	PVC, CPVC, ABS SCH40 closed/open	Up to 1-1/2"	None	3"	1/4"	7/8"	None	None	None	Foam backer rod	N/A	1-3/4	2	

INSTALLATION INSTRUCTIONS

These instructions are for the installation of through penetration fire stop system in minimum 3.5" thick steel or wood stud fire rated gypsum wallboard partitions. Refer to above drawings and System Configuration Information for component details.

1. Clean all hole and pipe surfaces in penetration area to remove loose debris, dirt, oil, wax, grease, old caulking, etc.
2. Gun, trowel, and/or pump firestopping sealant to a minimum 1/2" depth in annular space on both sides of wall. Trowel sealant surfaces flush with wall surfaces and to a smooth defect-free finish.

Plastic pipe through gypsum wall with collar

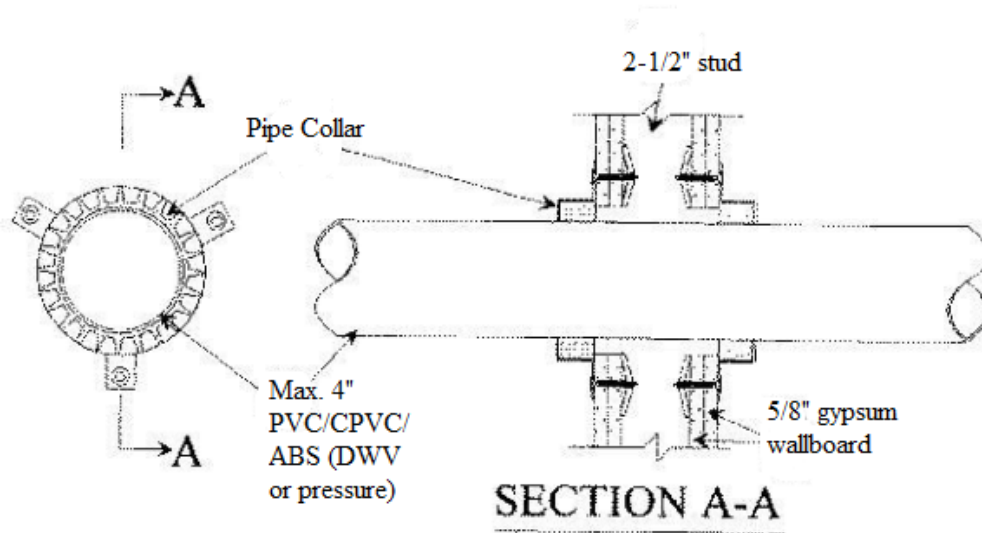

System Configuration Information															
Product(s)			Penetrating Item(s)			Hole Size	Annular Spacing		Additional Installation Materials and Aids			Backing Material		ASTM E814 Rating	
Pipe collar	None	None	Type	Size	Insulation	Max.	Min.	Max.	Wire Mesh	Steel Sleeve	Other	Type	Depth	T	F
Caulk	3/4" both sides	None	ABS or PVC/CPVC (foam or solid core) SCH40 (or heavier) closed or vented	Up to 4"	None	5"	1/4"	1/4"	None	None	None	N/A	N/A	0	2

INSTALLATION INSTRUCTIONS

These instructions are for the installation of through-penetration fire stop system in a minimum 3.5" thick steel or wood stud fire rated gypsum wallboard partitions. Refer to above drawings and System Configuration Information for component details.

1. Cut hole in gypsum wallboard in required size to accommodate pipe penetration and allowable annular spacing. Do not exceed maximum specified hole diameter.
2. Install up to 4" ABS or PVC/CPVC (foam or solid core) vented (DWV) or closed (pressure) pipe. Support pipe rigidly on both sides of wall.
3. Clean all hole and pipe surfaces in penetration area to remove loose debris, dirt, oil, wax, grease, old caulking, etc.
4. Install appropriate size Pipe Collar for corresponding plastic pipe diameter on both sides of wall. Secure collar in place through anchor tabs with minimum 1-7/8" gypsum laminating screws.

Plastic pipe through gypsum wall with wrap strip

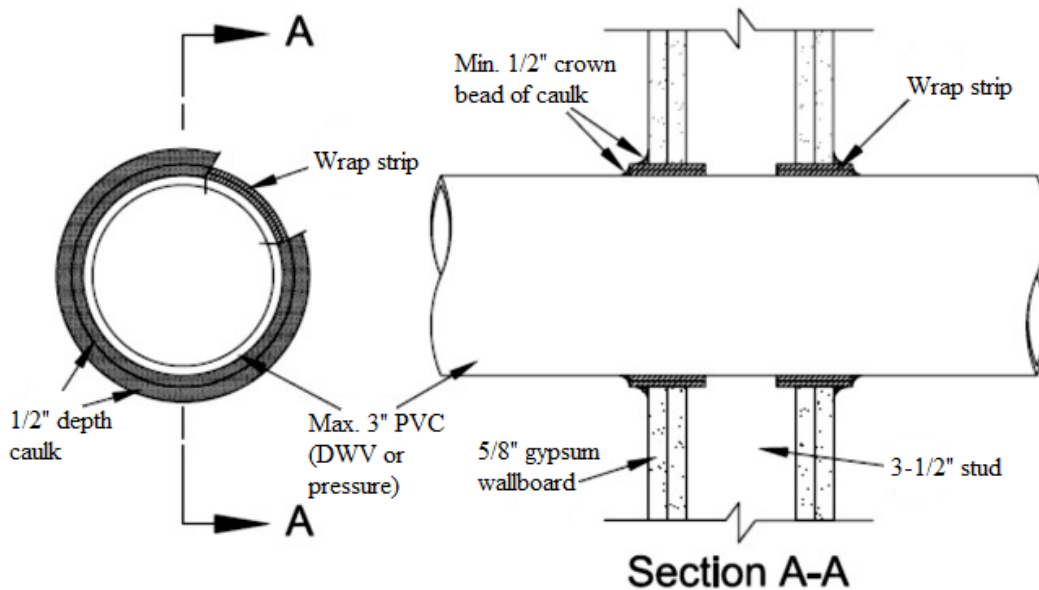

System Configuration Information																
Product(s)			Penetrating Item(s)			Hole Size	Annular Spacing			Additional Installation Materials and Aids			Backing Material		ASTM E814 Rating	
Fill Mat'l	Min. Thick.	Other	Type	Size	Insulation	Max.	Min.	Max.	Wire Mesh	Steel Sleeve	Other	Type	Depth	T	F	
Wrap Strip	2" both sides	Caulk (1/2" depth)	PVC pipe SCH40 (or heavier) solid or cellular core, closed/vented	Up to 3"	None	5"	1/4"	1-1/4"	None	None	None	None	N/A	2	2	

INSTALLATION INSTRUCTIONS

These instructions are for the installation of through-penetration fire stop system in a minimum 3.5" thick steel or wood stud fire rated gypsum partitions. Refer to above drawings and System Configuration Information for component details.

1. Clean all hole and pipe surfaces in penetration area to remove loose debris, dirt, oil, wax, grease, old caulking, etc.
2. Tightly wrap 1 layer of 2" wide Wrap Strip around pipe. Recess into annular space such that 1/4" extends beyond the surface of the wall on each side.

Plastic pipe through concrete floor with collar

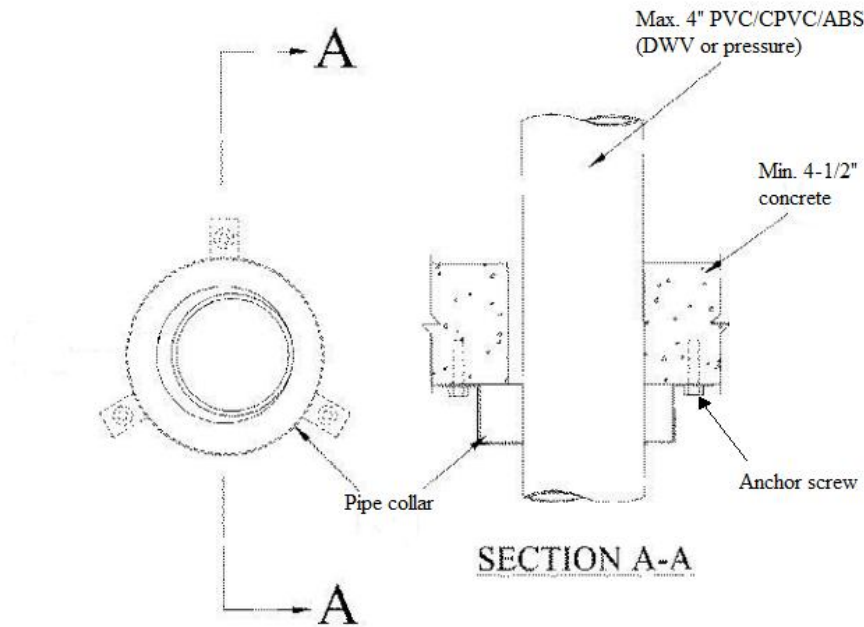

System Configuration Information															
Product(s)			Penetrating Item(s)			Hole Size	Annular Spacing		Additional Installation Materials and Aids			Backing Material		ASTM E814 Rating	
Fill Mat'l	Min. Thick.	Other	Type	Size	Insulation	Max.	Min.	Max.	Wire Mesh	Steel Sleeve	Other	Type	Depth	T	F
Pipe collar	None	None	ABS or PVC/CPVC (foam or solid core) SCH40 (or heavier), closed or vented	Up to 4"	None	5"	0"	1/2"	None	None	1/4" x 1-1/4" concrete anchor screws	None	N/A	3	3

INSTALLATION INSTRUCTIONS

These instructions are for the installation of through-penetration fire stop system in a minimum 4-1/2" thick lightweight or normal weight (100-150 pcf) concrete or hollow-core floors. Refer to above drawings and System Configuration Information for component details.

1. Cut hole in concrete floor in required size to accommodate pipe penetration and allowable annular spacing. Do not exceed maximum specified hole diameter.
2. Clean all hole and pipe surfaces in penetration area to remove loose debris, dirt, oil, wax, grease, old caulking, etc.
3. Install up to 4" ID ABS or PVC/CPVC (foam or solid core) vented (DWV) or closed (pressure) pipe. Support pipe rigidly on both sides of floor.
4. Install appropriate size Pipe Collar for corresponding plastic pipe diameter on bottom side of floor. Secure collar in place through anchor tabs with 1/4" x 1-1/4" concrete anchor screws.

Sanitary and branch pipe through wood floor with collar

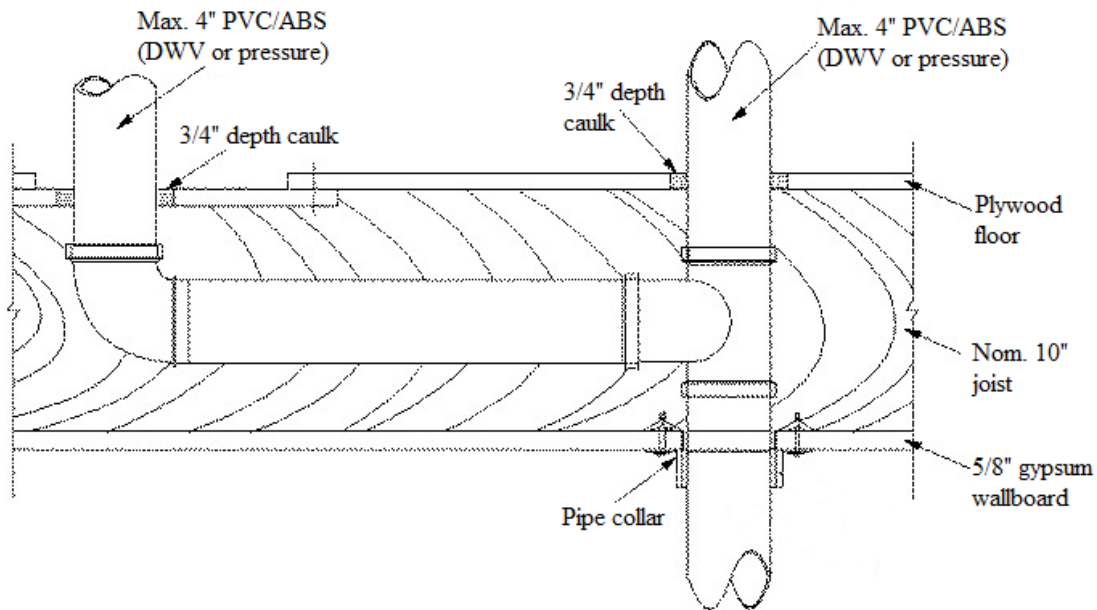

System Configuration Information																
Product(s)			Penetrating Item(s)			Hole Size	Annular Spacing			Additional Installation Materials and Aids			Backing Material		ASTM E814 Rating	
Fill Mat'l	Min. Thick.	Other	Type	Size	Insulation	Max.	Min.	Max.	Wire Mesh	Steel Sleeve	Other	Type	Depth	T	F	
Pipe Collar & caulk	None 3/4"	None	ABS or PVC (foam or solid core) SCH40 (or heavier) closed or vented	Up to 4"	None	5"	0"	1/2"	None	None	Minimum 3/4" wood screws	None	N/A	1	1	

INSTALLATION INSTRUCTIONS

These instructions are for the installation of through-penetration fire stop system in a wood floor/ceiling construction. Refer to above drawings and System Configuration Information for component details.

1. Cut hole in wood floor and gypsum ceiling to required size to accommodate pipe penetration and allowable annular spacing. Do not exceed maximum specified hole diameter.
2. Install up to 4" ID ABS or PVC/CPVC (foam or solid core) vented (DWV) or closed (pressure) pipe. Support pipe rigidly on both sides of floor/ceiling.
3. Gun, trowel, and/or pump sealant to a 3/4" depth in annular space on top of wood floor. Trowel sealant surfaces flush with floor surface and to a smooth defect-free finish.
4. Install appropriate size Pipe Collar for corresponding plastic pipe diameter on bottom side of gypsum ceiling. Secure collar in place through anchor tabs with 1-1/2" laminate screws in conjunction with 1/4" x 5/8" washers.

Plastic pipe through gypsum wall with sleeve

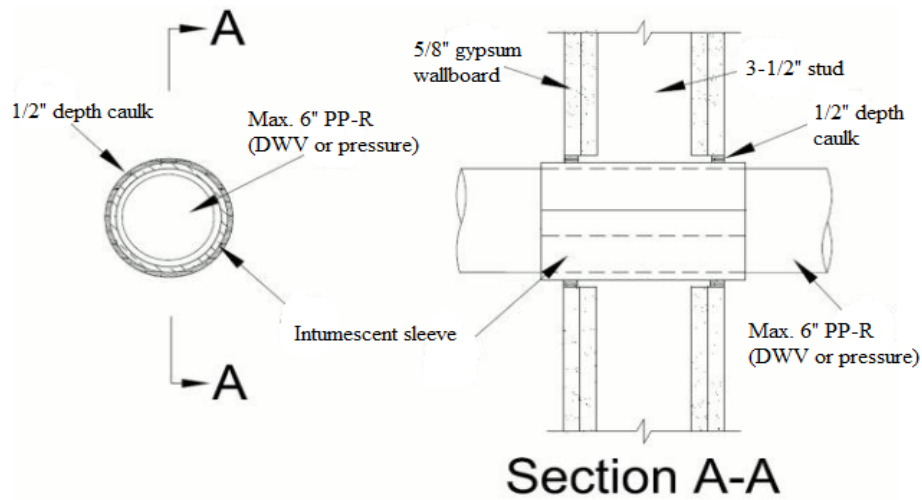

System Configuration Information															
Product(s)			Penetrating Item(s)			Hole Size	Annular Spacing		Additional Installation Materials and Aids			Backing Material		ASTM E814 Rating	
Fill Mat'l	Min. Thick.	Other	Type	Size	Insulation	Max.	Min.	Max.	Wire Mesh	Steel Sleeve	Other	Type	Depth	T	F
Sleeve	N/A	N/A	Polypropylene (PP-R) Pipe (closed or vented)	Up to 6"	None	8"	0"	7/8"	None	None	None	N/A	N/A	2	2
Caulk	1/2"														

INSTALLATION INSTRUCTIONS

These instructions are for the installation of through-penetration fire stop system in a minimum 3.5" thick steel or wood stud fire rated gypsum partition. Refer to above drawings and System Configuration Information for component details.

1. Clean all hole, pipe and insulation surfaces in penetration area to remove loose debris, dirt, oil, wax, grease, old caulking, etc.
2. Select the proper sleeve to fit the diameter of pipe used.
3. Wrap the sleeve around pipe from either side of wall with the intumescent material side facing the pipe, allowing bare metal end to overlap approximately 2" (51mm).
4. Secure the sleeve around pipe with duct tape, fiberglass tape, pop rivets, hose clamps, or tie wire.
5. Push/slide the sleeve through assembly so that it is centered within wall.
6. Gun, trowel, and/or pump fire stopping sealant to minimum 1/2" depth on both sides of wall. Trowel sealant surfaces flush with wall surfaces and to a smooth defect-free finish.