



INTERNATIONAL SLURRY SURFACING ASSOCIATION

TECHNICAL BULLETIN

800 Roosevelt Road, Building C-312, Glen Ellyn, IL 60137

No. 100

Issued 1969
Revised 2/2018

Laboratory Test Method for Wet Track Abrasion of Slurry Surfacing Systems

1. Scope

- 1.1 This test method measures the wearing qualities of slurry surfacing systems under wet abrasion conditions. The Recommended Performance Guidelines for Emulsified Asphalt Slurry Seal and Micro Surfacing, ISSA A105 and A143, provide specific target values for wet track abrasion test results.

NOTE: This test method is **NOT TO BE USED FOR FIELD WET TRACK TEST EVALUATIONS**

2. Referenced Documents

- 2.1 ISSA Technical Bulletins:
 - A105 Recommended Performance Guideline for Emulsified Asphalt Slurry Seal
 - A143 Recommended Performance Guideline for Micro Surfacing
 - TB No. 113 Test Method for Determining Mix Time for Slurry Seal and Micro Surfacing Systems
- 2.2 ASTM Standards:
 - C 702 Reducing Samples of Aggregate to Testing Size
- 2.3 Other Documents:
 - Ng & Jones, "WTAT Machine Correlation" from the ISSA Proceedings, 1988
 - Benedict, "A Study of WTAT Variables" from the ISSA Proceedings, 1988

3. Significance

- 3.1 The test establishes the minimum emulsified asphalt content of a given slurry surfacing system.
- 3.2 Long term moisture susceptibility is determined by use of the six-day soak procedure.

4. Summary of Method

- 4.1 A mixture of the components identified by TB No. 113 is prepared. The mixture is immediately cast into the specified mold and struck off flush.
- 4.2 After removal of the mold, the specimen is cured by drying to a constant weight at 60°C (140°F). The cured specimen is immersed in a 25°C (77°F) water bath for a period of one hour or six days, then mechanically abraded under water with a weighted rubber hose for a specified time. The specimen is washed free of abraded material and dried to a constant weight. The loss in weight is expressed in grams and then loss per unit area is calculated.

5. Apparatus

- 5.1 Balance, capable of weighing 5,000 grams to within 0.1 gram.
- 5.2 Hobart planetary type mechanical mixer Models C-100, A-120, or N-50, equipped with a 2.27 kg ± 0.06kg abrasion head (without the hose), quick clamp mounting plate and flat bottom metal pan. See Figures 1 and 2. The abrasion head is weighed without the hose while manually supporting the floating collar. The pedestal of Hobart mixer models A-120 and N-50 must be modified with appropriately-sized spacers to create proper distance between the abrasion head and the specimen when elevated to the test position.
- 5.3 Suitable smooth surface bowl to contain sample during mixing.
- 5.4 Suitable mixing spoon or spatula of sufficient size to accomplish mixing.
- 5.5 Felt disk of suitable size, larger in diameter than the test specimen and smaller in diameter than the inside diameter of the pan, cut from 13.6 kg (30 lb.) saturated roofing felt.

- 5.6 Specimen mold diameter and depth is specified in Table 1 below. A raised lip mold is preferred but a flat surface mold is satisfactory.

TABLE 1

Hobart Mixer Model Number	C-100 and A-120	N-50
Mold Size, Depth/Inside Diameter	6.35 ± 0.6 mm (0.25" ± 0.025") / 280 ± 6 mm (11" ± 0.25")	6.35 ± 0.6 mm (0.25" ± 0.025") / 248 ± 6 mm (9.75" ± 0.25")

- 5.7 Sample strike-off apparatus such as a window squeegee of 300-360 mm (11.8-14.2 in) blade length or a dowel of 350-480 mm (13.8 -18.8 in) in length by 25-27 mm (1-1.1 inch) diameter.
- 5.8 Forced draft oven thermostatically controlled at 60°C(140°F) ± 3°C(5.4°F).
- 5.9 Constant temperature water bath maintained at 25°C (77°F) ± 3°C (5.4°F).
- 5.10 Hose made of 75-85 smooth Shore A hardness rubber reinforced with a double cord surface. The hose has a 19± 2 mm ID with a 4.75-5.75 mm wall thickness and is cut into 127 ± 3 mm lengths (0.75 inch ID x 0.21 inch wall thickness x 5 ± 0.125 inch length). When using the drilled hose abrasion head, the holes are drilled 90° to the convex and concave sides of the hose and spaced appropriately for attachment to the abrasion head. Holes are not necessary when using the quick-change rigid mandrel abrasion head.

NOTE: The only approved hose for this test is the Parker 7094-75304.

- 5.11 If necessary, a prop block or device to support the pan and mounting plate assembly so that the abrasion head floats on the sample during the test.

6. Procedure for Preparation of Test Specimen

- 6.1 Place the specimen mold on the disc of roofing felt so that when the mix is poured into the mold opening the entire sample is contained on the felt.
- 6.2 Split or quarter (according to ASTM C 702) a sufficient amount of the aggregate passing a No. 4 (4.75 mm) sieve to obtain at least 800 grams (at least 600 grams when using the N-50 machine).
- 6.3 Weigh the split, or quartered, sample into the mixing bowl.
- 6.4 The proper ratio of system components, based on dry aggregate weight, should be determined in the laboratory according to TB No. 113.
- 6.5 Using the spoon, or spatula, mix the mineral filler into the aggregate until uniformly distributed. Add the water and mix until all the components are uniformly wet. Add the emulsified asphalt and mix until the components are adequately coated and homogeneous. Do not mix longer than three minutes before casting. Quick-Set systems should only be mixed for 30 seconds and immediately cast.
- 6.6 Pour the mixture into the upper half of the mold opening. Starting at the top of the opening and working toward the bottom, move the mold strike-off apparatus in a back and forth motion completely filling the mold and levelling the mix with the lip. This process should be performed in a single pass and take no more than 15 seconds. When using the window squeegee, care should be taken to avoid making a depression in the center of the specimen.
- 6.7 Remove the mold and place the specimen in the 60°C (140°F) ± 3°C (5.4°F) oven within three hours of casting and dry to constant weight. The specimen should be dried for a minimum of 15 hours and for no longer than 30 hours.

7. Wet Track Abrasion Test

- 7.1 Remove the dried specimen from the 60°C (140°F) ± 3°C (5.4°F) oven, allow it to cool to room temperature, and record the weight to the nearest 0.1 gram within two hours.
- 7.2 When performing the one hour test, place the specimen in the 25°C (77°F) ± 3°C (5.4°F) water bath for 60 to 75 minutes. The sample must be submerged a minimum of 12.5 mm (0.5 in). When performing the six-day evaluation, testing should be initiated within 2 hours of the end of the six-day soak period. The water in the bath should be changed frequently to avoid contamination. Specimens should not be allowed to contact with each other.
- 7.3 If a separate water bath is used, remove the specimen and place in the flat bottom pan.
- 7.4 Cover to a depth of approximately 6.35 mm (0.25 inch) with 25°C (77°F) ± 3°C (5.4°F) water above the surface of the specimen.
- 7.5 Clamp the specimen to the pan and mounting plate.

- 7.6 Lock the rubber hose abrasion head on the shaft of the Hobart machine. Elevate the pan and mounting plate assembly so that the abrasion head floats on the sample during the test. Use the prop block, if necessary, to support the assembly during testing.
- 7.7 Set speed to the lowest setting of the Hobart machine. Operate the machine as indicated by the Equivalent Test Duration in the table below. Rotate or replace the hose after each run to obtain an unabraded section for the next test.

NOTE: To avoid improper abrasion, if the hose is not completely straight, do not use either convex or concave sides of the hose for the test.

TABLE 2
LOSS CORRECTION FACTORS FOR CORRELATION TO C-100

Hobart Model	Equivalent Test Duration	Multiply Grams Lost by the Appropriate Factor to Obtain Loss per Unit Area	
	Seconds	g / ft ²	g / m ²
C-100 ⁽¹⁾	300 ± 2	3.06 x 1.0	32.9 x 1.0
A-120 ⁽¹⁾	405 ± 2	2.78 x 1.17	29.9 x 1.17
N-50 ⁽¹⁾	315 ± 2	For losses ≥ 24.5g, use 3.48 x 0.78 ⁽²⁾	For losses ≥ 24.5g, use 37.5 x 0.78 ⁽²⁾
		For losses < 24.5 g, use 3.06 x 1.0 ⁽²⁾	For losses < 24.5g, use 32.9 x 1.0 ⁽²⁾

(1) See Ng & Jones "WTAT Machine Correlation"/ISSA Proceedings, 1988.

(2) See: Benedict "A Study of WTAT Variables" from the ISSA Proceedings, 1988.

- 7.8 Remove the specimen from the pan after the abrasion cycle and wash off the debris. Place the washed test specimen in the 60°C (140°F) ± 3°C (5.4°F) oven and dry to constant weight.
- 7.9 The dried specimen is removed from the 60°C (140°F) ± 3°C (5.4°F) oven, allowed to reach room temperature and weighed to the nearest 0.1 gram within two hours. The difference between this weight and the weight obtained in Section 7.1 is the grams abrasion loss.

8. Report

- 8.1 The abrasion loss per unit area is calculated by multiplying the grams abrasion loss from section 7.8 by the appropriate correction factor in Table 2, to the nearest gram. The report may also include:
1. Soaking Period
 2. Machine Used
 3. Running Time
 4. Grams Lost

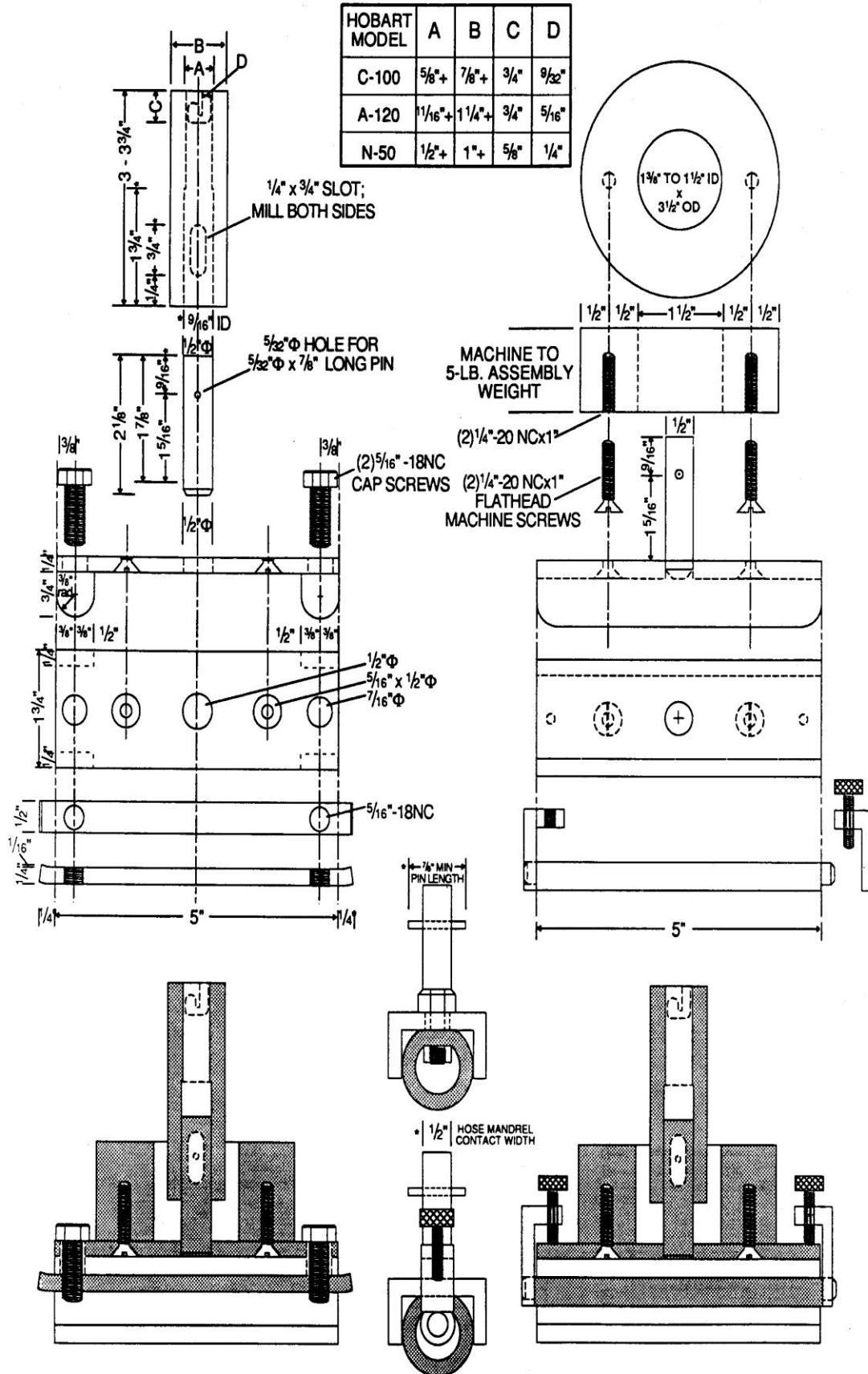

Conversion Table	
Inches	mm
1/16	1.59
5/32	3.97
1/4	6.35
9/32	7.14
5/16	7.94
3/8	9.53
7/16	11.11
1/2	12.7
9/16	14.29
5/8	15.88
11/16	17.46
3/4	19.05
7/8	22.23
1	25.40
1 1/4	31.75
1 5/16	33.34
1 3/8	34.93
1 1/2	38.10
1 3/4	44.45
1 7/8	47.63
2 1/8	53.98
3	76.20
3 1/2	88.90
3 3/4	95.25
5	127.00

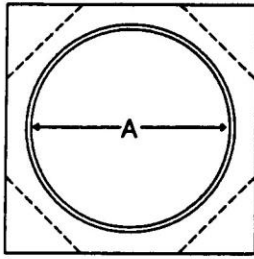

HOBART MODEL	A	B	C	D
C-100	11"	12-15"	1/4"	14 ga.
A-120	11"	12-15"	1/4"	14 ga.
N-50	9 3/4"	12-15"	1/4"	14 ga.

HOBART MODEL	A	B	C	D
C-100	279.4 mm	304.8 mm	6.35 mm	1.9 mm
A-120	279.4 mm	To	6.35 mm	1.9 mm
N-50	247.7 mm	381 mm	6.35 mm	1.9 mm

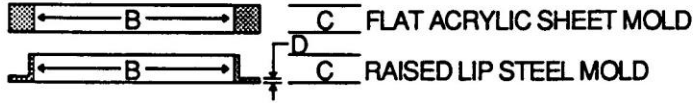

SPECIMEN MOLD

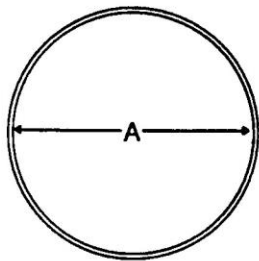

HOBART MODEL	A	B
C-100	13"	2-3"
A-120	13"	2-3"
N-50	11 1/4"	2"

HOBART MODEL	A	B
C-100	330.2 mm	50.8 - 76.2 mm
A-120	330.2 mm	50.8 - 76.2 mm
N-50	285.8 mm	50.8 mm

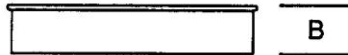

SPIN FROM .050"
ALUMINUM SHEET
3/16" BEADED EDGE

ABRASION PAN FOR QUICK-CLAMP BASE

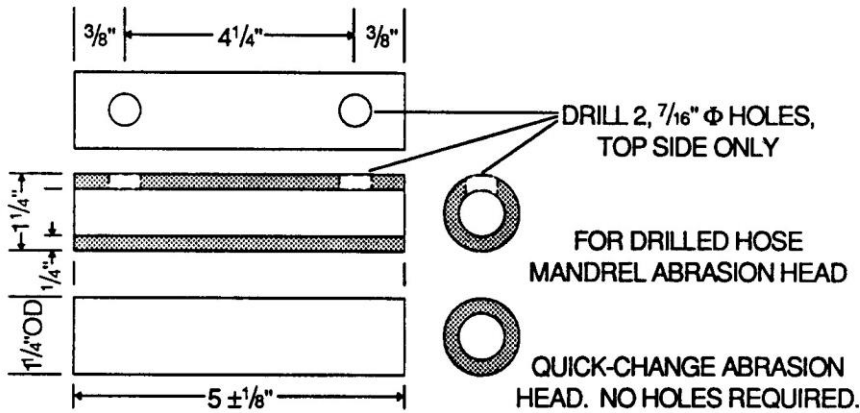

ABRASION HOSE

Conversion Table	
inches	mm
1/8	3.18
1/4	6.35
3/8	9.53
7/16	11.11
1	25.40
1 1/4	31.75
3 1/2	88.90
4	101.60
4 1/4	107.95
5	127.00

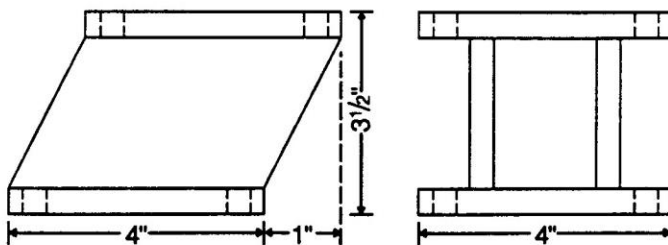

MODIFIED HOBART N-50 SPACER

Figure 1 – Hobart N-50

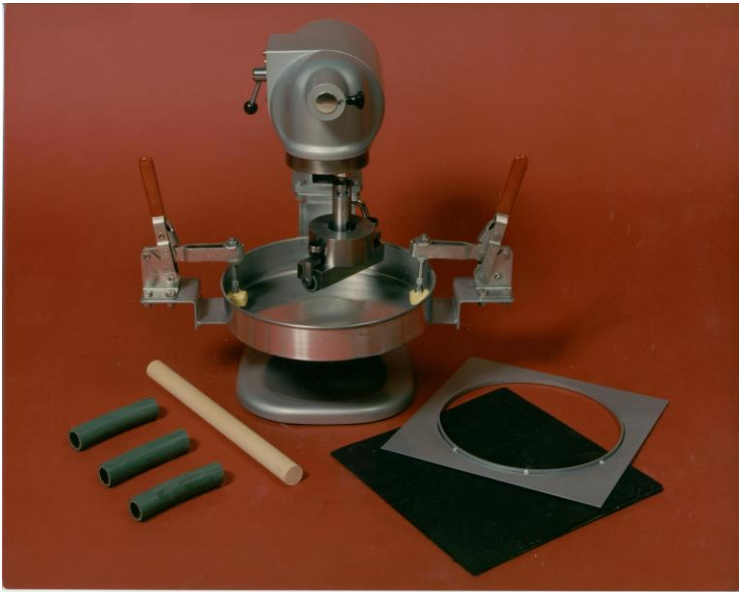

Figure 2 – Hobart C-100

