

United States Lifesaving Association

Lifesaving Sport Rules and Operational Procedures



Effective: July 2025

SECTION 1- GENERAL INFORMATION

1.1 INTRODUCTION

1.1.1 The 3 basic objectives of USLA Lifeguard Competitions are:

- a) to sustain and uplift employee morale.
- b) to stimulate personnel interest in rescue skill training; and
- c) to acquaint the general public with water safety procedures and skills used daily by professional lifeguards to advance public safety at the beach.

It is the further objective of the USLA to standardize the rules and regulation governing national and regional championship events, thereby contributing toward more harmonious relationships among the various lifeguard agencies and associated USLA Chapters.

1.1.2 The Rule book issued by the USLA is made for the proper advancement, encouragement, management, and administration of Lifesaving surf sports competitions in the United States. It is to be interpreted with the bylaws and policies of the USLA.

1.1.3 The Rule book binds the members of USLA to acknowledge and agree that:

- a) They are bound by, and will comply with, the rules and regulations of USLA as laid out in the Rule book.
- b) This Rule book is made for the collective benefit of the USLA, its members, surf lifesaving and surf sports. It aims to ensure a safe and fair system of which surf lifesaving competitions are to be regulated and conducted in the United States.
- c) The objective of this Rule book is to standardize the rules and regulations governing national and regional championship events, thereby contributing toward more unified structure amongst chapters.
- d) The purpose of this manual is to promote personnel interest in rescue skill training through lifesaving sport. This is aimed to acquaint the general public with water safety and skills used by professional lifeguards to advance public safety.

1.1.4 SAFETY

- a) The priority of competition is to provide a safe competitive environment. Due to the inherently dangerous nature of surf lifesaving, all competitors are assumed to have voluntarily read and understood this warning before participating.
- b) Safety for competitors, officials and non-competitors should be taken into consideration along with non-competition aspects including occupational health and safety measures. At any stage assessments may be undertaken and if they are unsatisfactory, the officials shall suspend all or parts of the competition. The committee shall then decide whether to postpone, cancel, or relocate all or parts of the competition.
- c) Before any competition, the Head Official must assess the prevailing and expected weather and surf conditions. Changes to the order of events may be made in this case to accommodate the upending weather.

1.2 POLICY

At no time must said USLA competition or personnel participation in said competition be permitted to interfere with established lifeguard operations or effective public safety on the membership's beaches. All lifeguard personnel competing or participating in USLA competition must be fully qualified members in good standing.

United States Lifesaving Association
Lifesaving Sport
Rules and Operational Procedures

1.3 SANCTION

Approval or consent of the USLA given to the Host of any lifeguard event for the utilization of the USLA Competition Rules and Regulations of said event. The rules and regulations are to be followed in all USLA sanctioned events.

1.4 HOST

The affiliate of the USLA or other USLA sanctioned Host under whose jurisdiction or within whose geographical area any sanctioned event shall fall.

1.5 EVENT REGISTRATION & FEES

- a) All competitors must register prior to the lifesaving competition in accordance with the procedures and deadlines established by the host organizing committee and the USLA Lifesaving Sport Committee.
- b) Each Chapter must designate and register one team captain prior to the start of the competition.
- c) RELAYS are to be registered by TEAM CAPTAINS ONLY.

1.6 ELIGIBILITY

- a) Each individual must be a PROFESSIONAL, LIFE or ALUMNI MEMBER of a USLA chapter lifeguard service. Associate Members are NOT eligible to compete.
- b) COMPETITORS must have fulfilled their USLA dues obligation prior to the commencement of the competition.
- c) Non-USLA member foreign competitors who are current members of a national lifesaving organization that is a Full Member of the International Life Saving Federation are also eligible to compete, subject to approval, and must apply in writing by sending a request for approval to the Lifesaving Sports Committee Chair at lifesavingsport@usla.org for a waiver of eligibility requirements and will not be eligible for awards or points, and may only compete in individual events, with the exception of Beach Flags.
- d) USLA National and Regional Lifeguard Competitions are intended for bona fide lifeguards who have demonstrated a commitment to US lifesaving – people who are lifeguards first, competitors second.
- e) USLA considers it unethical to recruit competitors for their high-performance athletic ability whose lifeguard/lifesaving credentials are tenuous or merely convenient for purposes of competition. Team management personnel and coaches are the key to preventing such unethical practices and must emphasize “play within the rules” behavior.
- f) The official on-site physician may declare a competitor ineligible if they are determined to present a physical danger to themselves or others.

1.7 COMPETITION CATEGORIES

All USLA Championship events will consist of the following:

- a) USLA Competition Events – USLA Competition Events shall be conducted as one of the five following age group/gender categories:
 - 1) **Open** – Any member of a USLA Chapter may compete
 - 2) **Open Men** – Open only to male members of a USLA Chapter
 - 3) **Open Women** - Open only to female members of a USLA Chapter
 - 4) **Master’s Men** - Restricted to 30 years plus male age groups in five-year increments. (30-34, 35-39, 40-44, 45-49, 50-54, 55-59, 60-64, 65-69, 70-74, 75 and above).
 - 5) **Master’s Women** - Restricted to 30 years plus female age groups in five-year increments. (30-34, 35-39, 40-44, 45-49, 50-54, 55-59, 60-64, 65-69, 70-74, 75 and above).

*All competitors must wear assigned colored wrist bands based upon their age group category.

United States Lifesaving Association
Lifesaving Sport
Rules and Operational Procedures

b) Open Mixed Team Events (1)

- 1) Mixed Surf Boat Race –1 Man/1 Woman– maximum of 4 Mixed teams per Chapter

c) Open Men’s Events (17)

- 1) Surf Race
- 2) Run-Swim-Run
- 3) Board Race
- 4) Surfski Race
- 5) Ironman
- 6) American Ironman
- 7) Beach Flags
- 8) Beach Sprint-
- 9) 2 Kilometer Beach Run
- 10) Solo Surfboat Race
- 11) Surf Boat Race
- 12) Board Rescue Race – maximum of 4 Men’s teams per Chapter
- 13) Rescue Race – maximum 4 Men’s teams per Chapter
- 14) Beach Relay – maximum 4 Men’s teams per Chapter
- 15) Taplin Relay – maximum 4 Men’s teams per Chapter
- 16) Paddleboard Relay – maximum 4 Men’s teams per Chapter
- 17) Landline Rescue Race- *maximum of 4 Landline teams total per Chapter regardless of gender

d) Open Women’s Events (17)

- 1) Surf Race
- 2) Run-Swim-Run
- 3) Board Race
- 4) Surfski Race
- 5) Ironwoman
- 6) American Ironwoman
- 7) Beach Flags
- 8) Beach Sprint-
- 9) 2 Kilometer Beach Run
- 10) Solo Surfboat Race
- 11) Surf Boat Race
- 12) Board Rescue Race – maximum of 4 Women’s teams per Chapter
- 13) Rescue Race – maximum of 4 Women’s teams per Chapter
- 14) Beach Relay – maximum of 4 Women’s teams per Chapter
- 15) Taplin Relay – maximum of 4 Women’s teams per Chapter
- 16) Paddleboard Relay – maximum of 4 Women’s teams per Chapter
- 17) Landline Rescue Race- *maximum of 4 Landline teams total per chapter regardless of gender

e) Masters Age Group events (9)

- 1) Surf Race
- 2) Run-Swim-Run
- 3) Board Race
- 4) Surfski Race
- 5) Ironman / Ironwoman
- 6) American Ironman / American Ironwoman
- 7) Beach Flags
- 8) 2 Kilometer Beach Run
- 9) Surf Boat Race

United States Lifesaving Association
Lifesaving Sport
Rules and Operational Procedures

- i. Masters Age Group Ocean individual events and the Surfboat event are conducted in five-year age groups.
- ii. In the Surfboat event, the team shall consist of two competitors: they shall compete in the age group of the younger competitor.
- iii. A competitor may only race in an open event plus their respective age group or a younger age group.
- iv. Competitors are restricted to one age group per event.

1.8 USLA NATIONAL LIFEGUARD CHAMPIONSHIP EVENTS (18)

- 1) Surf Race
- 2) Run-Swim-Run
- 3) Board Race
- 4) Surfski Race
- 5) Ironman / Ironwoman
- 6) American Ironman / American Ironwoman
- 7) Beach Flags
- 8) Beach Sprint
- 9) 2 Kilometer Beach Run
- 10) Solo Surfboat Race
- 11) Surf Boat Race
- 12) Mixed Surf Boat Race – 4 teams per Chapter*
- 13) Board Rescue Race – 4 teams per Chapter*
- 14) Paddleboard Relay – 4 teams per Chapter*
- 15) Beach Relay – 4 teams per Chapter*
- 16) Rescue Tube Race – 4 teams per Chapter*
- 17) Landline Rescue Race – 4 teams per Chapter*
- 18) Taplin Relay – 4 teams per Chapter*

1.9 SCORING

Chapter points shall be awarded in each Championship event.

- a) Open Men's and Open Women's individual events and Surf Boat events, according to the following schedule:

1 st Place = 20 points	9 th Place = 8 points
2 nd Place = 18 points	10 th Place = 7 points
3 rd Place = 16 points	11 th Place = 6 points
4 th Place = 14 points	12 th Place = 5 points
5 th Place = 13 points	13 th Place = 4 points
6 th Place = 12 points	14 th Place = 3 points
7 th Place = 11 points	15 th Place = 2 points
8 th Place = 10 points	16 th Place = 1 point

- b) For all Open Team events with 3 or more competitors per team (i.e., Beach Relay, Taplin Relay, Landline Rescue Race, Rescue Race, Board Relay) the points shall be awarded as follows:

1 st Place = 30 points	9 th Place = 12 points
2 nd Place = 27 points	10 th Place = 10.5 points
3 rd Place = 24 points	11 th Place = 9 points
4 th Place = 21 points	12 th Place = 7.5 points
5 th Place = 19.5 points	13 th Place = 6 points
6 th Place = 18 points	14 th Place = 4.5 points

United States Lifesaving Association
Lifesaving Sport
Rules and Operational Procedures

7th Place = 16.5 points 15th Place = 3 points
8th Place = 15 points 16th Place = 2 points

- i. In Open events where only a limited entry of 10 competitors or teams is permitted in a final (Beach Relay, Rescue Race, Landline Rescue and Board Rescue Race) the placing for competitors from 11th to 16th place shall be determined based on the semi-final results.
 - ii. There is no requirement to run a B final where a limited entry of 10 competitors or 10 teams maximum is permitted, except for the Open Surf Boat event, where a B final will be conducted, if necessary. Equal points from a semi-final will be awarded for the competitors or teams finishing in 6th place, 7th place and 8th place in each semi-final. If there are more than 8 competitors in a semi-final, those finishing in 9th place and 10th place will be awarded no points.
In this instance the Finals equivalent points to be awarded for 11th to 16th place are as follows:
 - iii. Individual or Pairs Events:
 - 11th and 12th Place = 5.5 points determined by gaining 6th place in the semi-final
 - 13th and 14th Place = 3.5 points determined by gaining 7th place in the semi-final
 - 15th and 16th Place = 1.5 points determined by gaining 8th place in the semi-final
 - iv. Team Events:
 - 11th and 12th Place = 8.25 points determined by gaining 6th place in the semi-final
 - 13th and 14th Place = 5.5 points determined by gaining 7th place in the semi-final
 - 15th and 16th Place = 2.5 points determined by gaining 8th place in the semi-final
 - v. There are no additional "entry" points given for teams entering an event. The only points that may be gained are where a placing in the top 16 of an event is achieved. There is no point score "blocking" system. In events where two or more competitors per team participate, their team is eligible to earn all points for all placings achieved.
- c) Master's Age Group and U19 Professional Member Chapter points shall be awarded in each event according to the following schedule:
- 1st Place = 5 points
 - 2nd Place = 4 points
 - 3rd Place = 3 points
 - 4th Place = 2 points
 - 5th Place = 1 point
- d) Chapters cannot combine points to place higher in team standings. If a team, in a team event, consists of members from different Chapters, then they shall divide the Chapter points. All events shall score towards the team championship.
- e) Ties in overall team point scores shall be broken using the following system:
- i. Most first-place final finishes in all Open Divisions.
 - ii. Most second-place final finishes in all Open Divisions.
 - iii. Most third-place final finishes in all Open Divisions; ...and so on.
- f) Ties (dead heats) in finals shall be declared as such and the points divided equally among the teams involved.
- g) When a tie occurs in an ocean event that qualifies for a final, the tied competitors shall advance to the final. However, if there are insufficient places available in the final, a repêchage heat shall be conducted between the tied competitors to determine the finalist.
- h) No points shall be credited to any team if an event is cancelled-even if some heats have been run.
- i) Competition results will be posted on the USLA website: www.USLA.org.

United States Lifesaving Association
Lifesaving Sport
Rules and Operational Procedures

1.10 USLA COMPETITION AWARDS

- a) The USLA shall provide standardized awards for each competitor placing within, but not limited to, first through fifth position in all USLA Championship events.
- b) **The Howard Lee Trophy** is the perpetual team trophy awarded to the overall point score National Lifeguard Championship Division A championship team.
- c) **The Erik Jersted Trophy** is the perpetual team trophy awarded to the overall point score National Lifeguard Championship Division B championship team.
- d) **The “C” Division Trophy** is the perpetual team trophy awarded to the overall point score National Lifeguard Championship Division C championship team.
- e) Overall point score team trophies will be awarded to the top three highest scoring Chapter teams in Division A, Division B, and in Division C.
 - i. **Division A** - USLA Chapters comprised of lifeguard agencies with a number of lifeguards that exceeds 200 employees.
 - ii. **Division B** - USLA Chapters comprised of lifeguard agencies with a number of lifeguards between 51– 200 employees.
 - iii. **Division C** - USLA Chapters comprised of lifeguard agencies with a number of lifeguards between 1– 50 employees.
 - All Chapter Teams are considered in the "A" Division until they request and submit verification to be included in the "B" Division or in the “C” Division.
 - Requests must be done annually, and must include a letter from the involved agency/agencies employer(s) verifying the number of employed lifeguards.
 - The letter must be from an administrator (not the Captain or Chief of a Beach Patrol) from the agency/agencies that comprise the chapter. Letters must be from an official with the agency, not involved in the daily beach patrol operations. It must be received by the competition chair one week prior to the start of competition.
 - iv. No individual agency within a grouped Chapter may compete in both classes. No individual may compete for scoring points in the two different divisions.
 - v. Individuals may compete as "event-mates" in two and four person events being from different divisions and the points will be divided accordingly.
- f) **The Greg Farry Trophy** is the Open Point Score National Lifeguard Championship perpetual team trophy awarded to the Chapter team with the highest point score in the Open, Open Men’s and Open Women’s events only.
- g) **The Sheridan Byerly Perpetual Trophy** will be awarded to the USLA Region scoring the most points at the National Lifeguard Championships.
- h) **High Point Individual Trophy** awards will be presented to the male and female Competitor scoring the most points in the Open Mixed and Open Men’s or Open Women’s Categories, including Team Events and Relays.
- i) **The Billy George Sportsmanship Award** will be presented to the individual, who in the opinion of the Officials displayed the best sportsmanship at the USLA National Championships.
- j) No monetary awards may be offered or taken as a competitive award in USLA sanctioned events.

1.11 USLA CHAMPIONSHIP SCHEDULE

- a) USLA Championship events will be run independently and continuously from start to finish each day without interruption of any non-USLA events.
- b) No event shall be delayed due to equipment problems, subject to the discretion of the Head Official.
- c) Every USLA National Lifeguard Championship shall be held over the period of three days. It is suggested that competition begin at 8:00 a.m. each day. The competition schedule may be changed to comply with local conditions or to avoid placing competitors, officials, spectators, or

United States Lifesaving Association
Lifesaving Sport
Rules and Operational Procedures

equipment in danger.

1.12 USLA LIFESAVING SPORT COMMITTEE

The USLA Lifesaving Sport Committee shall consist of the Lifesaving Sport Representative/Coordinator from each USLA Region, or the Region's designee, and the USLA Lifesaving Sport Chairman.

SECTION 2 – ADMINISTRATION

2.1 EVENT OFFICIALS

Shall be appointed by the respective Lifesaving Sport Chairperson.

2.2 EVENT OVERSIGHT COMMITTEE

- a) The Lifesaving Sport Chairperson (or their designee) will be the Head Official.
- b) The Head Official will assign the Course Referees: start judges, finish judges, course judges and others of the corps of officials as deemed necessary. The Head Official, Course Referees and USLA Medical Advisor (if present) shall comprise the Event Oversight Committee.
- c) In consultation with the Host the Event Oversight Committee shall have the power to postpone or cancel any or all events, and to alter the venue of the competition, owing to weather or other unforeseen circumstances.
- d) The Committee shall make every effort within its power to see that all rules, requirements and operational procedures of the USLA Competition Manual are followed.

2.3 AREA ALLOCATION

The Head Official is empowered to define the respective competition and marshaling areas for all events.

2.4 BUOY PLACEMENT

All buoys shall be placed by the Host under the direction of the Head Official or their designee, meeting the USLA distance requirements as conditions warrant. Buoy placement must be done prior to the starting of the competition.

2.5 OFFICIATING WATER CRAFT

The Host must provide a boat, or other suitable craft approved by the Head Official and manned by an efficient crew, that shall be in attendance at the buoys during all swimming events. Failure to provide a suitable craft shall result in the Head Official or his designee refusing to sanction the holding of events.

Every official's craft must be equipped with a 2-way radio for communications with officials on the beach and standard safety equipment.

The craft shall be assigned to the competition and free from all other routine lifeguarding responsibilities.

2.6 CRAFT SCALE(S)

The craft scale(s) will be available the day prior to the commencement of competition. It is the responsibility of each competitor to ensure that their craft meets the minimum weight requirement and equipment standards as defined in Section 6 of these rules.

2.7 ASSOCIATION OFFICIALS IN CHARGE

Once the competition has begun the Event Officials (National, Regional, Local) are in charge.

SECTION 3 – OFFICIALS AND THEIR DUTIES

3.1 NOTIFICATION

Officials should be notified of the competition and their appointment to a particular position at an event and of the time to report for briefing, etc. Notification should within be a reasonable amount of time.

3.2 OFFICIAL UNIFORMS

Officials shall be provided with and wear a distinctive uniform.

3.3 THE HEAD OFFICIAL

In conjunction with the Event Oversight Committee,

- a) Shall be responsible for all matters relating to the actual conduct of the competition. Shall have the power to make any alteration in the schedule that they deem necessary. An announcement shall be made of such alteration.
- b) Shall appoint a Protest Committee as required to consider and adjudicate protests.
- c) Shall consider and adjudicate on any unbecoming conduct during the competition or event.
- d) Shall, if required, exercise the power to disqualify or penalize a competitor. The Head Official is not required to give notification of any disqualification or penalty until the conclusion of the relevant event.
- e) Shall have the power to refer the offense and/or offenders to the Association (National, Regional, Local), for consideration of further penalty.

3.4 COURSE REFEREES

Course Referees shall be appointed by the Head Official to control and organize events of the competition. While in control of a particular event they shall be responsible only to the Head Official.

3.5 FINISH JUDGES

- a) Determine the order of finishing of contestants.
- b) Report on any infringement of competition rules to the Course Referee.
- c) Position themselves to have an uninterrupted view of the finish line.
- d) Assign finish places to the competitors as they complete the event.

3.6 OTHER JUDGES

Other Judges may be utilized as needed, with their duties defined by the Course Referee and the relevant event. They may include water judges, break judges, timers and awards presenters.

3.7 STARTER(S)

- a) Has sole jurisdiction over the competitors for the start.
- b) Recall the competitors by pistol shot (rapid), by whistle signal or by other means, if in their opinion the start is an unfair one. Recall signal must be consistent during the competition.
- c) Has the power to disqualify a competitor for starting before their time, or for willfully disobeying orders, or for any other obstruction during the start.
- d) Notify the Course Referee of all disqualifications.

3.8 MARSHAL

- a) Shall assemble the competitors for events and place the Competitors into heats.
- b) Shall insure that competitors are ready to compete, and that they present themselves with their equipment and competition attire when called to the event.
- c) Shall render competitors liable for disqualifications for failure to comply with their directions. Such competitors shall be reported to the Course Referee.

- d) Shall insure that any competitors warming up after the start of the first heat must not interfere in any way with the conduct of any aspect of the competition.
- e) Shall review the event details and rules with the competitors, including the start, the course and the finish.
- f) Shall see that all competitors under his control are in proper uniform and regulation caps as laid down by the Association.
- g) Shall have the power to prevent a competitor from starting an event if they are wearing a uniform that is of objectionable nature or one failing to comply with the Association's standards. The Marshal shall notify the Course Referee of all such actions.

3.9 COURSE RECORDERS

Shall record the order in which each placed competitor or team finishes in each event, together with the time where necessary.

3.10 SCOREKEEPER

The Scorekeeper shall:

- a) Keep a running total of the points scored.
- b) Provide official results and/or score sheet after the conclusion of the competition.
- c) Post the competition results on USLA.org as appropriate.

3.11 ANNOUNCER

The Announcer shall:

- a) Receive and broadcast the official results as they are made available.
- b) In cooperation with the Course Officials, notify competitors of the timing of upcoming events and appropriate venues.
- c) Keep the spectators informed, acknowledge sponsors and, where applicable, describe the events and explain the running of the events to maintain public interest.
- d) Shall be required to attend all briefings of the Competition Officials.

3.12 PRESENTATION OFFICIAL

The Presentation Official will be responsible for all awards being presented during the event

SECTION 4 – GENERAL COMPETITIVE RULES AND PROCEDURES

4.1 EQUIPMENT

The following is a list of equipment to aid the running of an efficient competition. The list is not intended to be exhaustive, but merely to outline basic equipment items. It is suggested that the Host of a competition propose amendments and/or additions to the list to aid future competition.

- a) Flags and buoys (recommended color and size, see Figure 4.1)
- b) Poles and cones (for beach markers)
- c) Rope, lines and anchors with chain (see Figure 4.2)
- d) Lane markers
- e) Judge's stand
- f) P.A. system
- g) Starter megaphones
- h) Three 32-caliber starter's pistols (or equivalent, or air horns if starter's pistols are not available)
- i) Whistles
- j) Twenty stop watches
- k) Boats or PWCs for Water Judges
- l) 10 – 12 Hand-held portable radios (for 2-way communication between the officials)
- m) Crowd control line
- n) Flag standards for water starts and finishes
- o) Registration Desk (personnel, forms, pens, pencils, markers, etc.)
- p) Competition course information area
- q) Vehicles (for equipment and surfboat transportation)
- r) Tractor (for possible spectator mounds)
- s) Minimum of two cordless drills with auger bits per venue with adequate back-up batteries and chargers
- t) Two "Craft Scales"
- u) Cut pieces of rubber hose, 12" in length, for Beach Flags (minimum of 50)

4.2 COMPETITION AREA SETUP

All competition related set up shall be placed by the Host under the direction of the Head Official or their designee, meeting the USLA distance requirements as conditions warrant. Flag and buoy placement must be done prior to the starting of the competition.

4.3 COMPETITION CAPS / HELMETS / JERSEYS / SWIMWEAR

- a) Each individual Chapter shall be responsible to design and produce an official Chapter Competition cap (beanie) that identifies their Chapter.
- b) The Chapter's official cap shall be worn on the head of the competitor and securely fastened under the chin at the start and finish of each event. Competitors shall not be disqualified for loss of their competition cap after the start if they complete all aspects of the event and it can be determined that they did not voluntarily remove their cap during the event.
- c) Competitors must wear their current official Chapter's cap, not that of any other Chapter.
- d) Competition caps shall be required in every event except the Surfboat event.
- e) In the Surfboat event helmets MUST BE WORN.
- f) Design of Chapter cap shall be subject to approval of the USLA Competition Committee.

- g) All finalists must wear event sponsor competition jerseys, if provided, otherwise Vests or Lycra tops are optional.
- h) Referee has the authority to exclude any competitor whose swim wear does not comply with the following standards: The swim wear of all competitors shall be in good moral taste and not carry any symbol which may be considered offensive. All swim wear shall be non-transparent. Competitors shall not wear or use anything that may aid buoyancy.
- i) Other Apparel- Swim goggles may be worn. The wearing of protective sunscreen is permitted. Sunglasses or optical glasses may be worn in all events with the exception of Beach Flags where eye protection or optical glasses worn must be suitably designed for that event. Jewelry that, in the opinion of the Referee, has the potential to cause injury to either the wearer or other competitors must be removed or taped over prior to the competition.

4.4 COMMERCIAL IDENTIFICATION POLICY

The Event Oversight Committee reserves the right to order the removal or coverage of commercial identification in conflict with official championship sponsors. This includes body tattoos.

Notwithstanding the foregoing, official sponsors of chapters and teams may retain their identification on competition apparel and equipment irrespective of commercial conflict, but must not display other signs, banners, flags, or other identification within close proximity to the competition arena.

Competitors in all craft event heats, semi-finals, and finals may be required to carry championship sponsor signage affixed on craft or equipment provided. Team and individual sponsor signage on craft and equipment will not be covered unless it is unavoidable when fitting the championship sponsor signage. Every co-operation is requested in this regard; the support of sponsors helps to curtail significant expenses that would otherwise be passed onto competition participants.

4.5 HEATS/FINALS COMPETITOR LIMITS

The Course Referees shall decide whether events will be conducted in heats, semi- finals, or finals providing that the maximum number of competitors in a heat, or final race, shall not exceed the following, while also taking into account safety and the prevailing conditions.

EVENT	Max. no. of competitors/race
Beach Sprint (90M)	10 competitors
Beach Relay	10 teams of 4 competitors
Rescue Tube Rescue Race	10 teams of 4 competitors
Landline Rescue Race	10 teams of 4 competitors
Board Rescue	10 teams of 2 competitors
Board Race	16 competitors
Board Relay	16 teams of 3 competitors
Solo Surfboat	<u>10 competitors</u>
Surfboats	<u>10 teams of 2</u>
Mixed Surfboat	<u>10 teams of 2</u>
American Ironman / American Ironwoman	16 competitors
Surf Ski	16 competitors
Beach Flags	24 competitors
Ironman / Ironwoman	24 competitors
Taplin Relay	24 teams of 4 competitors
Surf Race	32 competitors
Run-Swim	32 competitors
Beach Run – 2 km	

Head Official may authorize changes to these maximum numbers with due consideration for effective judging, environmental conditions, safety considerations and fairness for all competitors.

4.6 HEAT PLACEMENT

Competitors will be placed in heats by a draw or random computer placement. As much as is possible, an effort shall be made to have competitors from the same Chapter in different heats.

4.6.1 Draws

The initial draw for heats and beach positions may be conducted by competition management and supplied to teams. Draws for positions in subsequent rounds (e.g., quarter-finals, semi-finals, and finals) shall be made by competition officials. The method used for the draws, including draws for initial heats and seeding of competitors, shall be approved by the Head Official.

- a) The Head Official will be responsible for all draws for quarters, semis, and finals where heats have taken place.
- b) Vacancies created by the disqualification of a competitor or team shall only be filled by the next place getter participating in the same race. Vacancies created in qualifying to further rounds of an event due to the withdrawal of a competitor or team shall only be filled by the next place getter who participated in the same race.

4.6.2 Competitor Limitations

The Head Official or Course Referee shall decide whether events shall be conducted in heats, rounds, quarterfinals, semi-finals, or straight-out finals. Only the Head Official may authorize changes to these maximum numbers with due consideration for effective judging, environmental conditions, safety considerations and fairness for all competitors.

Note: Technical Officials should be mindful of confirmed entries when determining the number of heats/rounds required to conduct an event through to a final and to, as far as practicable, have an equal number of competitors in each heat/round. The Head Official may change the number of competitors in remaining heats, after one or more have been run, if safety conditions warrant, providing that the number going through to the next round/heat, quarter, semi, or final do not compromise the number of qualifiers from earlier heats.

- a) To assist with the fair conduct of competition if there is an even number of competitors in a heat, wherever practicable, at least half the competitors who correctly complete the course should progress to the next round of the event (e.g., if there are 16 starters in a race at least 8 who correctly complete the course should qualify for the next round of the event).
- b) If there is an uneven number of competitors in a heat, wherever practicable, at least half the competitors less one who correctly complete the course should progress to the next round of the event
(e.g., if there are 9 starters in a race at least 4 who correctly complete the course should qualify for the next round of the event)
(e.g., if there are 13 starters in a race at least 6 who correctly complete the course should qualify for the next round of the event)

4.7 FINAL EVENT QUALIFICATION

- a) Equal numbers of top finishers from each heat will be placed into the Final.
- b) Where necessary Quarterfinals and Semi-Finals will be run.
- c) The numbers taken to reach a final should not exceed the following, taking safety into account:

Rescue Relay, Board Rescue, Landline, Surfboat	10 Teams
Beach Relay, Beach Sprint, Solo Surfboat	10 Teams or 10 Individuals
Beach Flags, Board Race, Surfski Race, American Ironman & American Ironwoman, Board Relay	16 Individuals or 16 Teams
International Irons, Taplin Relay,	24 Individuals or 24 Teams
Surf Race, Run-Swim-Run	32 Individuals

- d) The Quarter and Semi Finals can be less than ten competitors per heat to comply with the mathematical formula necessary to accommodate the ultimate goal of reaching 10, 16, or 32 competitors for the Final.
- e) Only competitors who appear and register for the heats of an event shall be eligible to compete in the event's Quarter Finals, Semi Finals or Final.
- f) When one or more competitors or teams withdraw from a final of 16 or more competitor/team, up to a maximum of four competitors or teams shall be called forward from the reserves list. Reserves will come from the same qualifying race as the withdrawn competitor or team. The final shall not be re-seeded.
- g) Where one or more competitors or teams withdraw from an A-Final of 10 competitors alternate competitors up to a maximum of four competitors, or teams, shall be called forward from the heats. Reserves will come from the same qualifying race as the withdrawn competitor or team.

4.8 SUBSTITUTIONS IN TEAM EVENTS

Substitutions are permitted in any round of team events.

Substitutes must be from the same USLA chapter. Only the chapter manager or coach may substitute members in a team event with other members from the same chapter.

Managers or coaches must notify the appropriate officials of the substitution(s) no later than 30 minutes prior to the start of the first round of the team event or 30 minutes prior to the commencement of marshalling in subsequent rounds whichever occurs first.

Only lifeguard competitors who have not previously competed in earlier heats of the event are permitted to be used as substitutes. Lifeguard competitors that previously competed in earlier heats and were eliminated are ineligible to be used as substitutes in the same event.

4.9 GROUPS

- a) Open Men, Open Women, and Master age group events will be run independently of each other.
- b) Masters age groups may be run together. Groups can be combined only with the consent of the affected competitors, or when two groups combined total no more than the maximum number of competitors allowed per event.
- c) All groups will always be placed and scored separately.
- d) The preferred order will be Open Men first, Open Women second, and Masters age groups as follows: 30-34, 35-39 Men, 30-34, 35-39 Women, 40-44, 45-49 Men, 40-44, 45-49 Women, etc.

4.10 DISQUALIFICATION

- a) Any competitor who violates the rules of a given event may be disqualified. Competitors or teams may be disqualified from an event or from the entire competition. Where a competitor is disqualified for any reason, in a heat or a final, the place he/she would have held shall be awarded to the competitor who finished next and all lower placing competitors shall be advanced 1 place.

- b) Where a competitor is disqualified for any reason the event results shall not include a place or time for the competitor. Where a competitor does not finish an event (DNF), the event results shall not include a place or time for the competitor.
- c) The "One Start Rule" shall be used in all events.
 - 1) All competitors who START (i.e. commence a starting motion) after assuming a final set position, and before the starting signal, shall be disqualified, except for Beach Flags in which the competitor(s) shall be eliminated.
 - 2) If the starting signal sounds before the disqualification is declared, the competitors shall be called back and start again.
 - 3) The signal to call back the competitors shall be the same as the starting signal but repeated.
 - 4) Any competitor who is disqualified for a false start shall not be permitted to continue in the race and must withdraw from the starting line.
 - 5) All competitors who fail to comply with the starter's commands, disturbs others in the race through sound or otherwise, may be disqualified or eliminated (in the case of Beach Flags).
 - 6) Any competitor that is deemed to be unsportsmanlike by the officials may be disqualified for the remainder of the competition.
 - 7) Competitors or teams who are deemed to have competed unfairly may be disqualified from an event or expelled from the competition. The referee may refer the competitor or team to the disciplinary committee for consideration of further penalty.

Examples of competing unfairly include:

- i. Committing a doping or doping-related infraction.
- ii. Impersonating another competitor.
- iii. Competing twice in the same individual event.
- iv. Competing twice in the same event in different teams.
- v. Purposely interfering with a course to gain an advantage.
- vi. Jostling or obstructing other competitors or handlers so as to impede their progress.
- vii. Receiving physical or material outside assistance (other than verbal or other direction except where specifically excluded by the rules of the event). Anyone aiding a competitor shall cause that competitor to be subject to disqualification (exceptions shall include equipment handlers) and may themselves be disqualified.

The referee and/or the relevant official(s) shall have absolute discretion in determining whether a competitor, team, or handler has competed unfairly.

- 8) Fighting will not be tolerated. Any competitor involved in a fight shall be disqualified from the remainder of the current competition as well as any USLA sanctioned competitions in the following year.
- 9) Striking any official is grounds for a lifetime suspension from USLA events and may also result in criminal prosecution.
- 10) Any competitor entering the water in the competition area, in an event that they are not currently participating in shall be subject to disqualification.

4.11 PROTESTS

- a) Protests shall be in writing, on an official Protest Form, made by the protesting TEAM CAPTAIN ONLY and shall be accompanied by a \$25 US cash filing fee, within 30 minutes of the incident. Protests made by any other team member may result in disqualification of the individual or team from the event or the remainder of the competition.
- b) Protests may be lodged for reasons of ineligibility of a competitor or equipment, a rule violation by a competitor, or may include impediment by competitors, judges or bystanders.

- c) The judgment calls of the officials are not subject to protest.
- d) Protests are to be presented to the Head Official.
- e) A Protest Committee shall be appointed by the Head Official. Such Committee shall be made up of three Event Officials. The Protest Committee shall review and adjudicate the protest.
- f) The Protest Committee may use any available material, including digital cameras, video cameras or any evidence relevant to the incident.
- g) The Protest Committee shall come to a final decision as expeditiously as possible, and no later than the commencement of the next level of that competition, unless the event has already proceeded to the next level of competition or documentation (such as verification of employment) is not readily available.
- h) Protests which are successful shall be refunded the filing fee.
- i) Further penalties, disqualifications, suspensions, etc. may be imposed at a later time.
- j) Protests and subsequent rulings shall be reviewed at the next regularly scheduled Competition Committee meeting.

4.12 DRUG POLICY

- a) The USLA condemns the practice of doping in sport. Doping is cheating and against the rules and ethics of sport. It is harmful to the image of sport and may be harmful to competitors.
- b) The USLA is committed to contribute towards and support the USOC policies and procedures aimed at the prevention of doping in sport and the achievement of drug free sport, and as a member federation of the International Lifesaving Federation (ILS), is committed to observing the requirements of the World Anti-Doping Agency (WADA) as laid down in ILS Policies and procedures.
- c) A policy of drug free competition with possible drug testing has therefore been adopted and endorsed by the USLA at all events. All Competitors may be subjected to drug testing.

SECTION 5 – OCEAN AND BEACH EVENTS

OCEAN AND BEACH EVENTS

The following ocean and beach events are described in this section:

10 Individual:

Surf Race
Run-Swim-Run
Board Race
Surfski Race
Ironman / Ironwoman
American Ironman / American Ironwoman
Beach Flags
Beach Sprint
2km Beach Run – 2km
Solo Surfboat

8 Team:

Surfboat Race
Mixed Surfboat
Board Rescue Race
Rescue Tube Rescue Race
Landline Rescue Race
Beach Relay
Taplin Relay
Paddleboard Relay

5.1 GENERAL CONDITIONS FOR OCEAN COMPETITION

Team management and competitors are responsible for being familiar with the competition schedule, and with the rules and procedures governing events.

- a) Competitors may not be permitted to commence in an event if they are late reporting to the marshalling area. To assist the organizers in determining how many heats may be required, events may be marshaled the day before or at the start of the day the event is scheduled.
- b) A competitor or team absent from the start of an event shall be disqualified.
- c) Unless specifically provided for, no artificial enhancements to propulsion may be used in competition (e.g., hand paddles, fins, hand webs, armbands).
- d) The use of wax or similar substances to assist the competitor in maintaining the grip on or contact with boards or surf skis or paddles is permitted in ocean events.
- e) Competitors must wear their chapter, club or National Team swim caps in all events. Ocean event caps, securely fastened under the chin, must be worn on competitors' heads at the start of each event.
- d) A competitor shall not be disqualified if the cap is lost after the start of an event provided that officials can identify that the competitor correctly completed the event.

5.1.2 Competition Courses:

Protests against the course will only be accepted prior to the start of each event.

- a) All courses shall be measured, set, and aligned to the referee's satisfaction ensuring as far as possible, that all lanes have fair and equal conditions.

- b) The USLA Event Management Committee and Head Official may authorize adjustments to course set-ups to ensure the safety, fair judging and efficient running of the event (e.g., distances, number of lanes or buoys, number of competitors per race).
- c) Master's Age Group Event course distances may be shortened where practical and possible to ILS Masters distances.
- d) Any course changes must be communicated to competitors prior to the start of the race (e.g., at the team managers briefing, in the marshalling area, or at the start).
- e) The use of color-coded buoys and flags is recommended to guide competitors accurately through the required courses.
- f) Buoy distances shall be measured from the end of knee-depth water at low tide mark. However, distances may vary depending upon beach conditions and safety factors. Adjustment of the buoys may be necessary during the competition if they move out of alignment.
- g) Competitors in craft events may pass through the swimming buoys on their craft on the understanding that they are solely responsible if the buoys offer an impediment to their progress.
- h) Competitors and officials must leave the designated competition area when not competing or officiating. The competition area may be defined as the section of the beach encompassed by a line or fence, or a direct line to the water from the extreme ends of a line or fence or other designated areas as specified by the referee.
- i) Judges' order-of-finish decisions are not subject to protest or appeal.
- j) Start decisions by the Starter or Head Official (or Head Official's designate) are not subject to protest or appeal.

5.1.3 Luck of prevailing conditions:

- a) No protest or appeal will be entertained when an incident is caused by the conditions of the surf or by the prevailing conditions. Surf conditions affect the conduct of and participation in surf lifesaving competitions.
- b) Competitors acknowledge and accept that open water competitions can be affected by environmental conditions beyond the control of organizers (e.g., water or beach conditions, or inclement weather) and that competitors are subject to luck of the prevailing conditions.
- c) The Head Official and/or relevant official(s) have absolute discretion in determining whether an incident has been caused by the luck of the prevailing conditions.

5.2 THE START

5.2.1 Prior to the start

- a) A Marshal shall:
 - Place competitors in the order as drawn for all heats and or finals.
 - i. Accompany competitors and their required equipment to the starting area and ensure those competitors are positioned in proper order.
- b) Prior to the start of each race, designated technical officials shall:
 - i. Check that all officials are in position.
 - ii. Check that competitors have proper attire and caps for a legal start.
 - iii. Check that equipment and course markers are in position.
- c) A designated official e.g., Sectional Referee shall signal the Starter that the competitors are under the Starter's control.

5.2.2 The Starter

- a) The Starter shall:
 - i. Have sole jurisdiction over the competitors from the time of the signal until the race has started.
 - ii. Position himself or herself so as to have full visual control over all competitors during the start.
- b) Ensure that the start for all races is consistent and fair.

- c) Disqualify competitors for false starts (or in Beach Flags, eliminate competitors).

5.2.3 Start Procedures

- a) The process of starting events should be a three-step process commencing with a signal or command that indicates **“Take Your Mark”** followed by a signal or command that indicates **“Set”** and then followed by a start signal or command that indicates **“Go”**.
- b) The start procedure may be clarified at the Team Managers Briefing.
- c) See individual event descriptions for the start procedures for Beach Flags, and Surf Boat.
- d) If, for any reason, the Starter has to speak to any competitor after either command, the start process shall be recommenced.
- e) If, for any reason, the Starter is not satisfied that all is ready for the start to proceed after competitors are on their marks, the Starter shall order all competitors to withdraw from their marks and recommence the start.
- f) While the Starter makes every attempt to effect a fair start, the decision to “go” on the start signal rests with the competitor or team.
- g) If there is no recall by the Starter, Check Starter or Chief Referee, no protest or appeal shall be allowed on the start.
- h) After the start, competitors in swim, board, surf ski (if a dry start), and multi-discipline events may enter the water at their own discretion, providing there is no interference to other competitors.
- i) In relay or multi-discipline events, after completion of the first leg, the competitor entering the water in second or subsequent legs shall be deemed to be at fault if the progress of a competitor coming from the water is impeded.

5.2.4 START COMMANDS

The following three-step start shall be used in all ocean events listed in Section 6.

- a) On the starter’s **“Take your marks”** command, competitors assume a position in their marshaled order at the start line.
- b) On the starter’s **“Set”** command, competitors immediately assume their steady starting stance.
- c) When all competitors are stationary, the starter gives the acoustic starting signal or command that indicates **“Go”**.

5.2.4 Start lines

- a) Start lines may be designated by:
 - A cord between two poles.
 - A line drawn on the sand between two poles.
 - A line of sight between two poles or otherwise as determined by the Starter.
- b) At the start, competitors’ toes may be on or behind the start line (whether a cord, drawn on the sand or line of sight) but parts of the body may overhang the line.
- c) In beach events: where a line is drawn, toes and fingers shall be on or behind the line except where an upright starting position is adopted. In such circumstances, competitors’ toes shall be on or behind the line, but parts of the body may overhang the line.
- d) In board events: where a cord designates the start line, a part of the board held by competitors may be over the start line but it must be at right angles to the line or at an angle to accommodate prevailing conditions. Where a board is placed on the beach, it shall be placed at 90 degrees to, and on the shoreward side of, the start or changeover line.
- e) In surfboat and surf ski events: where a line of sight is used, the bow of the craft shall be on or behind the line and at 90 degrees to the line or at an angle to accommodate the prevailing conditions.

5.2.5 Disqualification

- a) The one-start rule shall be used in all events. The first competitor or team that commences a forward starting motion after assuming a final set position and before the starting signal shall be disqualified, except for Beach Flags in which the competitor shall be eliminated.
- b) If the starting signal sounds before the disqualification is declared, the competitors shall be called back and start again.
- c) The signal to call back the competitors shall be the same as the starting signal but repeated.
- d) Any competitor who is disqualified for a false start shall not be permitted to continue in the race and must withdraw from the start line.
- e) All competitors who fail to comply with the Starter's commands within a reasonable time shall be disqualified.
- f) Any competitor who, after the Starter's first command, disturbs others in the race through sound or otherwise, may be disqualified or eliminated (in the case of Beach Flags).

5.2.6 Notes:

- a) The duty of the Starter and Check Starter is to ensure a fair start. If the Starter or Check Starter decides that a start is not fair, for any reason, including technical or equipment fault, surf conditions, or other matters not caused by competitors, the competitors should be called back, and the start process shall recommence.
- b) Competitors shall be disqualified if they "commence a forward starting motion" prior to the starting signal. Involuntary movement by itself e.g. a muscle twitch or wash from waves for in-water starts is not a disqualification. Anticipating the starting signal and commencing a starting motion is a disqualification.
- c) The Starter and Check Starter use their discretion in determining whether a competitor – or more than one competitor – has commenced a starting motion. Commonly, the early starting motion of one competitor causes movement by other competitors. Such movements by the other competitors are not a DQ. 4. The Starter's or Check Starter's decisions on starts are not subject to protest or appeal.
- d) While every endeavor should be made by the starter to effect an even and fair start, the decision to "go" on the start signal rests with the competitor or team. If there is no recall by the starter or the Check Starter(s) or the Chief Referee, no protest shall be allowed on the start.

5.2.7 Changeovers and tagging in relays

- a) Exchanges or changeovers in relay events shall be effected by a competitor "tagging" the next team member unless otherwise provided (see Beach Relay).
- b) In tagging, one competitor uses either hand to visibly touch the other competitor on the hand or other part of the body. All tags must be performed above the water surface so that they are visible.
- c) The outgoing competitor shall be positioned with feet on, or on the shoreward side of, the changeover line.
- d) Competitors in relay events must start their leg of the race from the position or lane allotted by the Marshal. If competitors do not start from their designated lane or position, the team risks being disqualified.

5.2.8 Draws for position

- a) The initial draw for heats and beach positions may be conducted by random draw and supplied to teams.
- b) Draws for positions in subsequent rounds (e.g., quarter-finals, semi-finals, and finals) shall be made by competition officials.
- c) The method used for the draws, including draws for initial heats and seeding of competitors, shall be approved by the referee.

5.2.9 Beach positions

- a) For swimming, ski, board, multi-discipline and surfboat events, starting positions and lanes shall be consecutively numbered from the left to right (facing the water) starting with the number 1.
- b) For beach events, the number 1 position shall be nearest the water.

5.3 THE FINISH

- a) In events where competitors run across a finish line, they must cross the line on their feet and in an upright position (i.e., not fall across the line). The finish is judged on the chest of the competitor when crossing the finish line.
- b) In events with in-water finishes such as surf skis and surf boats, competitors or teams or crews are deemed to have finished when any part of the craft crosses the finish line.
- c) In events where competitors are required to cross a finish line, and fail to do so correctly, competitors may recover and correctly re-cross the finish line to record their placing.
- d) Once a competitor has been judged to have correctly crossed the finish line, he or she is deemed to have completed the race. The competitor may not re-enter the course to correct any previous race errors.
- e) The referee may authorize the wearing of electronic finish tags to aid the judging and recording of races. Competitors must place tags as directed (e.g., around a specified ankle or wrist or placed on a designated part of their craft/boat). The result of such races shall then be determined by the order of the finish of the tags across the finish line. In the event of failure of the electronic tags, all placings in a race shall be visually judged using normal methods.

5.3.1 Judging

- a) All events shall be judged visually or by electronic means. Placing shall be decided by finish Judges. Ties (dead heats) shall be declared as such.
- b) Where available, electronic equipment (including video or other technology judging aids) should be utilized in the judging process.
- c) Should electronic means be used to aid the judging and recording of races, competitors must place tags as directed (e.g. worn in a vest, placed around a specified ankle or wrist or placed on a designated part of their craft/surf boat etc.). The result of such races shall then be determined by the order of the finish of the tags across the finish line. In the event of failure of the electronic tags, all placings in a race shall be visually judged using normal methods.
- d) Judges shall be positioned to ensure a clear view of the finish line. Where appropriate Judges shall be placed in elevated positions.
- e) Judge 1 selects finishers 1 and 2; Judge 2 selects finishers 2 and 3 and so on, (that is, Judge 1 is primarily responsible for finisher 1, as well as noting who finished second).
- f) Should video or other electronic judging aids be used to properly determine the result of a race, the initial judging result shall not be declared as final and the Head Official /Sectional Referee and Chief Judge shall determine the final finish result of the event.
- g) The Finish Judge results, when finalized, shall be regarded as final, and no protest or appeal shall be permitted.
- h) At the Chief Judge's signal, placing discs or decals shall be issued and/or names recorded.
- i) Where available, judges may use video/electronic equipment to assist them.
- j) The Chief Referee may allow competitors or team managers to view video playback, or other electronic judging aids under controlled circumstances.

5.3.2 Time limits

- a) A time limit may be imposed on the duration of an event at the Head Official's discretion. Competitors shall be advised of any time limits prior to the commencement of a round of the event.

- b) The Head Official may instruct competitors to withdraw from the event prior to finishing when the time limit has been reached or when the number of competitors required for subsequent rounds have qualified by completing the race without disqualification.

5.4 SEEDING

Seeding shall be used.

5.4.1 Seeding in heats

For the first round of an event, entries from the same club or nation will be seeded in different heats if possible.

5.4.2 Seeding in semi-finals and finals

- a) Seeding is required for all rounds after the heats. Seeding for further rounds, quarter-finals, semi-finals and finals shall be based on the result of heats.
- b) Based on the results of heats, and/or further rounds, or semi-finals, the top 16 competitors or teams shall be assigned places in the final of the following events: Beach Flags, Surfski Race, Board Race, Board Relay, Ironman/Ironwoman, American Ironman/American Ironwoman, Surfboat, Paddleboard Relay, Taplin Relay.
- c) Based on the results of heats, and/or further rounds, or semi-finals, the top 32 competitors shall be assigned places in the final of the following events: Surf Race, Run-Swim-Run.
- d) Where required (for point score purposes, etc.) an A final shall be conducted in the following events: Rescue Tube Rescue Race, Landine Rescue Race, Beach Relay and Board Rescue. Based on the results of heats or semi-finals, the top 10 competitors or teams shall be assigned places in the A-final. The 11th through 16th competitors or teams shall be assigned points based on finish placings in their respective semi-finals.

5.4.3 Draws for position

- a) The initial draw for heats and beach positions may be conducted by competition management and supplied to teams.
- b) Draws for positions in subsequent rounds (e.g., quarter-finals, semi-finals, and finals) shall be made by competition officials.
- c) The method used for the draws, including draws for initial heats and seeding of competitors, shall be approved by the Chief Referee.

5.5 SURF RACE

5.5.1 Event description

With a running start into the surf from the start line on the beach, competitors swim around the 400m course designated by buoys, around the left end #1 White buoy of the flag line to the two black and white buoys returning to shore passing the right end of the #10 Yellow/Blue flag buoy line to finish between the finish flags on the beach.

To facilitate the recording of placing after the finish, competitors may be positioned either:

- On a straight line drawn at approximately a 30-degree angle from the finishing line and up the beach.
- On a series of lines 10m behind and at right angles to the finishing line and 5m apart.

5.5.2 The course

As shown in the following diagram, the U-shaped course shall be approximately 400m from start to finish. To ensure fair starts and finishes, alignment of the start line and finish line to the buoys may be altered at the discretion of the referee, depending on the prevailing sea conditions.

- a) **The start line** – a brightly colored cord stretched between 2 poles approximately 40m apart – shall be situated 5m from the water's edge, centered on buoy number 1.
- b) **The finish line** – between 2 flags positioned 5m apart – shall be situated approximately 15m from the water's edge, centered on buoy number 10.
- c) **The swimming course** shall be marked by buoys (as indicated on the diagram) the furthest situated approximately 170m beyond knee-deep water. Water distances may vary depending upon sea conditions.

5.5.3 Judging

At the starting signal the competitors shall commence from the start line, enter the water without impeding any other competitors in the event, swim to and around the buoys, and return to shore and finish between the two green finish flags.

*Note: Competitors may touch buoys and buoy ropes but are not permitted to use buoy ropes to drag themselves along the course.

Competitors must finish on their feet in an upright position.

The finish is judged on the competitor's chest crossing the finish line.

Judges shall be placed to observe the conduct of the event as well as determine competitors' place at the finish line.

5.5.4 Disqualification

In addition to the General Rules the following behavior shall result in disqualification:

- i. Failure to complete the course as defined and described.
- ii. Any shifting or hassling for position in the finish funnel will result in disqualification.

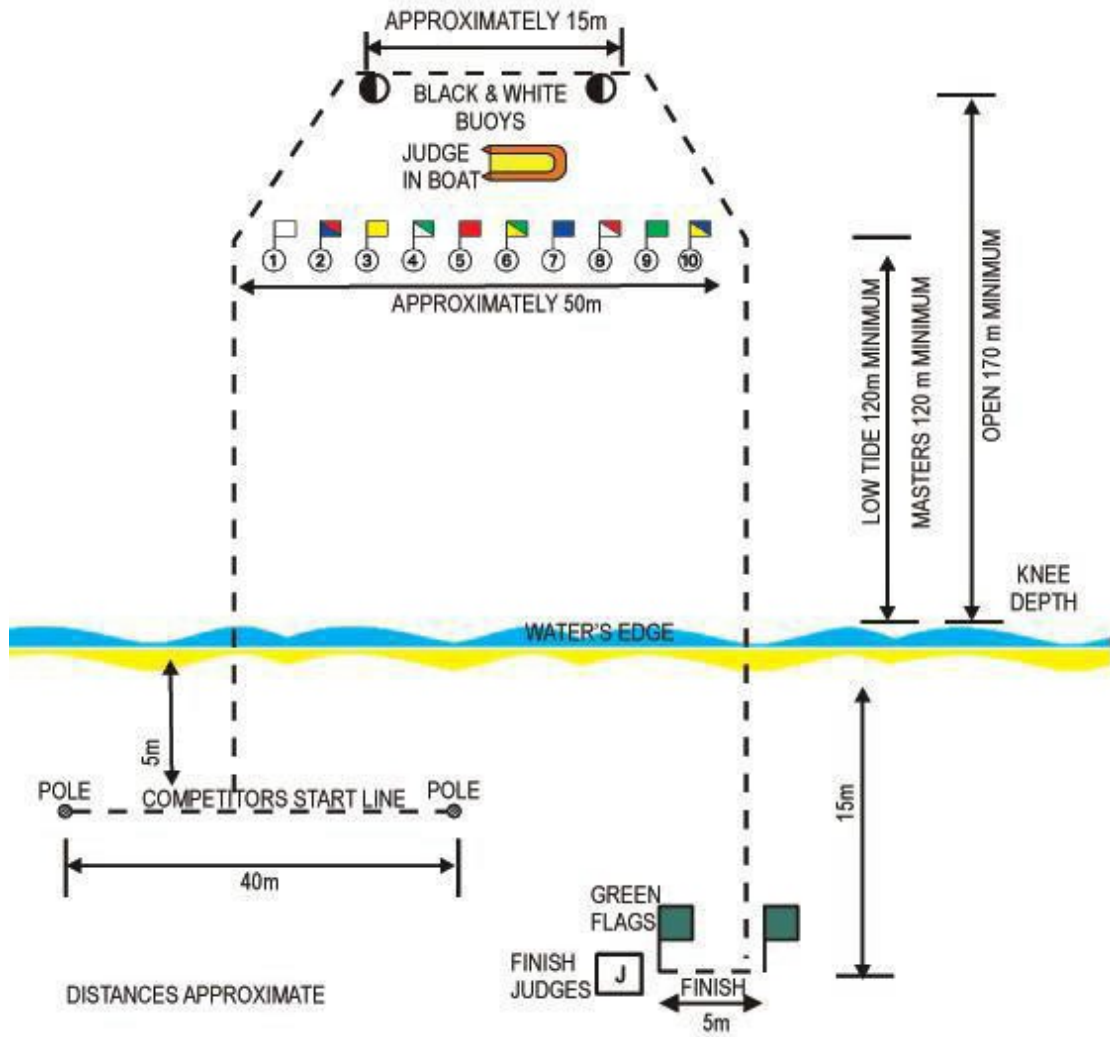

5.5 SURF RACE

5.6 RUN – SWIM – RUN

5.6.1 Event description

From the start line, competitors run to pass around the 2 turning flags and enter the water to swim out to and around the buoys. Competitors swim back to the beach to again run round the 2 turning flags before running to the finish line.

*Note: Competitors may touch buoys and buoy ropes but are **not** permitted to use buoy ropes to drag themselves along the course. The beach set up relative to the positioning of the buoys may be adjusted dependent to the sea conditions.

5.6.2 The course

As shown in the following diagram, the course shall be laid out so that competitors run approximately 150m, swim approximately 300m, and run approximately 150m to the finish. Any competitor that impedes or fails to complete the entire course will be disqualified.

Run

The competitors will run from the Start line to the 1st turn flag placed mid beach approximately 75 meters distant towards the right hand side of the course. After rounding the mid beach turning flag left shoulder (counterclockwise) competitors will run approximately 75 meters towards the near shore turn flag at the left side of the course and round that flag right shoulder (clockwise) and enter the water.

Swim

The competitors will swim clockwise around the White swim #1 flag buoy and along the flag line to the Yellow / Blue #10 flag buoy turning clockwise and returning to shore.

Run

When exiting the water, the competitors must run up to and turn left shoulder (counterclockwise) around the near shore turn flag and then run approximately 75 meters and turn right shoulder (clockwise) around the mid beach turn flag and run approximately 75 meters to the Finish line.

5.6.3 Judging

Competitors must finish on their feet in an upright position. The finish is judged on the competitor's chest crossing the finish line.

Judges shall be placed to observe the conduct of the event as well as determine competitors' place at the finish line.

5.6.4 Disqualification

In addition to the General Rules the following behavior shall result in disqualification: Failure to complete the course as defined and described.

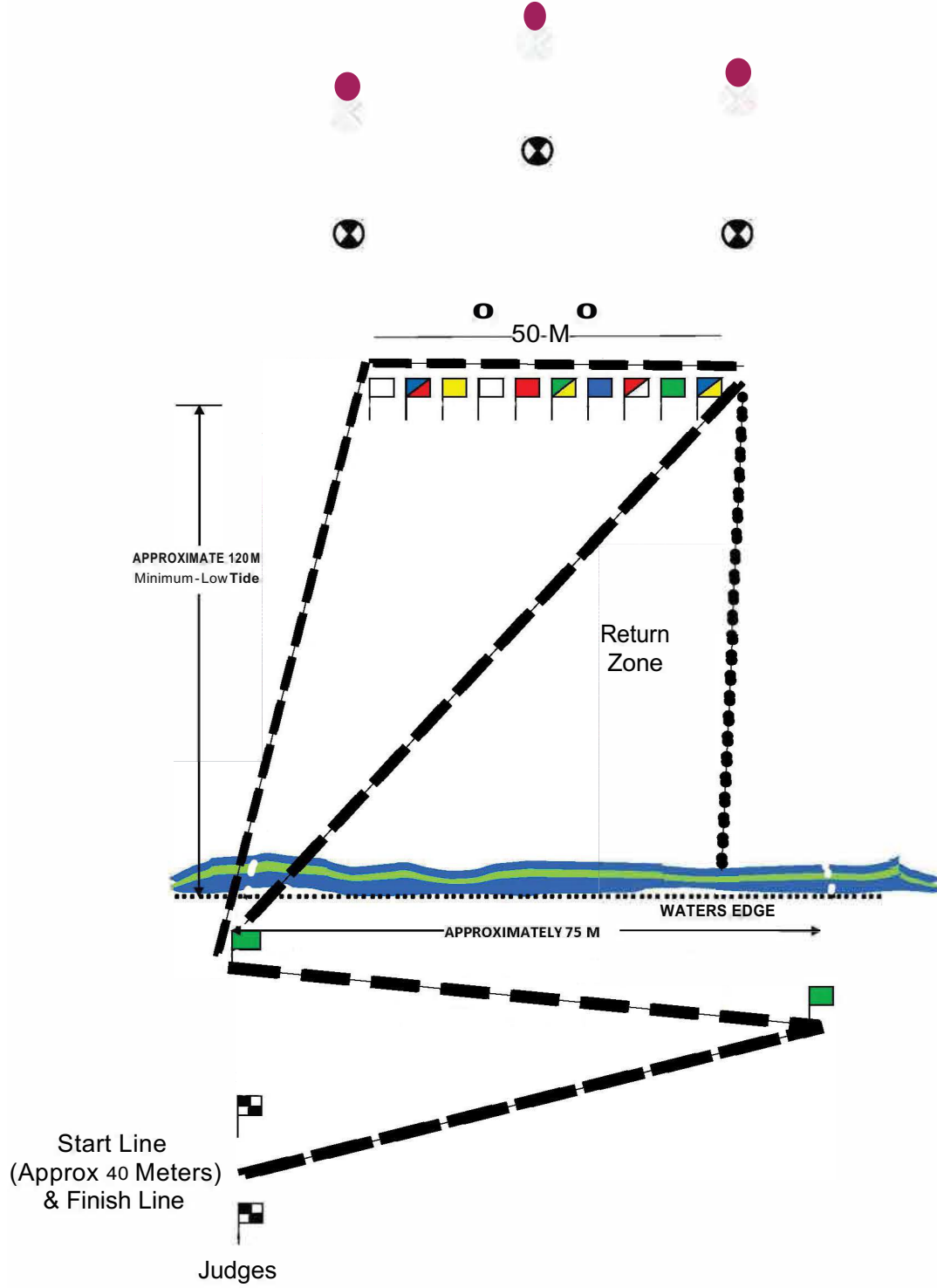

5.6 RUN-SWIM-RUN

5.7 BOARD RACE

5.7.1 Event description

A surfboard is a craft propelled primarily by a competitor's hands and arms. Refer to the USLA Equipment Standards Section for details

Competitors stand on or behind the start line on the beach with their boards 1.5 m apart.

At the start signal, competitors enter the water, launch their boards, and paddle the course marked by buoys, return to the beach, and run to cross the finish line.

Competitors are not permitted to hold or otherwise interfere with other competitors' boards or deliberately impede their progress.

5.7.2 The course

The course layout shall be as detailed in the following Board Race diagram.

To ensure fair starts and finishes, alignment of the start line and finish line to the buoys may be altered at the discretion of the referee, depending on the prevailing sea conditions.

Buoys:

Three buoys of the same color(s) and equal in size to a 50-litre drum shall be used: two "turning buoys" shall be placed approximately 75 m apart, and a minimum 250 m distance (same for Masters) from knee-depth water at low tide mark. The third "apex" buoy shall be placed midway and approximately 15 m seaward from the turning buoys thus forming an arc with them.

The start line, depicted by a bright colored cord, shall be situated on the beach approximately 5 m from the water's edge. It shall be 30 m in length and marked by two poles at either end. The middle of the start line should be aligned with the first turning buoy but may be altered at the discretion of the referee depending on the prevailing conditions to allow all competitors a fair passage around the first buoy.

The finish line: shall be situated on the beach approximately 15 m from the water's edge. It shall be 20 m in length and marked at each end by a flag on a 4 m pole. Finish flags shall be the same color(s) as the course buoys.

The middle of the finish line should be aligned with the third turning buoy, but this may be altered by the referee depending on the prevailing sea conditions.

5.7.3 Equipment

Boards: See Section 6 – *Equipment Standards*. The use of a replacement board is permitted provided that the competitor recommences the race from the start line. Replacement boards may be brought to the start line by fellow team members providing they do not cause any interference to other competitors.

5.7.4 Judging

The finish is judged on the competitor's chest crossing the finish line. Competitors must finish on their feet in an upright position while in control of the board.

Control of craft: Competitors may lose contact and control of their board without necessarily being disqualified. To complete the race, competitors must have (or have regained) their board and cross the finish line from the seaward side while maintaining contact with their craft

5.7.5 Disqualification

In addition to the *General Rules* the following behavior shall result in disqualification: Failure to complete the course as defined and described.

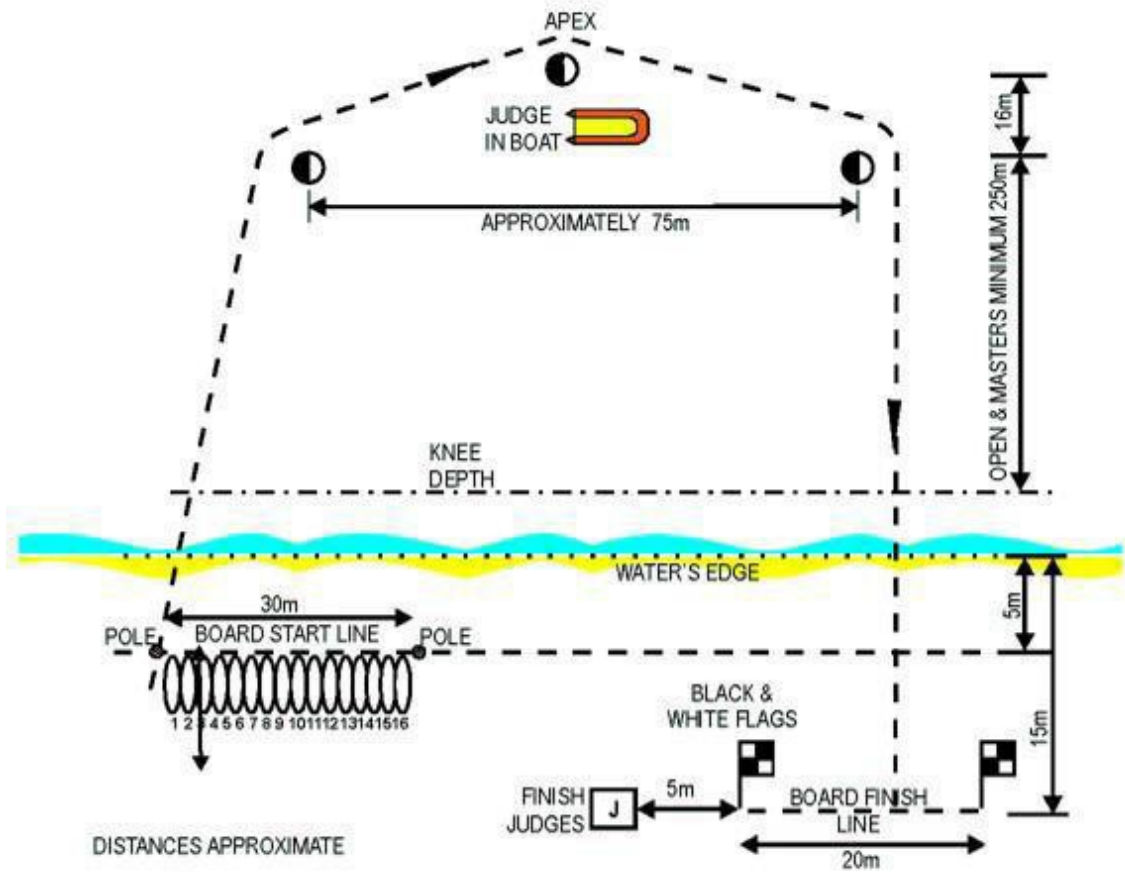

5.7 RESCUE BOARD RACE

5.8 SURFSKI RACE

5.8.1 Event description

A Single Surf Ski is a craft propelled primarily by a competitor with a paddle. Refer to the USLA Equipment Standards Section for details.

Competitors steady their skis in line in knee-deep water about 1.5 m apart. Competitors must obey directions from the starter or check starter concerning ski alignment at the start.

On the starting signal, competitors paddle their skis around the course marked by buoys and return to finish when any part of the ski crosses the in-water finish line – ridden, gripped, or carried by the competitor.

Competitors may lose contact and control of their ski without necessarily being disqualified. To complete the race competitors must have (or have regained) their ski and paddle and cross the finish line from the seaward side while maintaining contact with the ski and paddle.

Competitors are not permitted to hold or otherwise interfere with other competitors' skis or deliberately impede their progress.

Dry start and finish:

If conditions are such that the starter cannot provide a fair start, a dry start and/or dry finish shall be used. See below

5.8.2 The course

The course layout shall be as detailed in the following diagram.

To ensure fair starts and finishes, alignment of the start line and finish line to the buoys may be altered at the discretion of the referee, depending on the prevailing water conditions.

Buoys:

Three buoys equal in size to a 50-liter drum shall be used: two “turning buoys” shall be placed approximately 75 m apart, and a minimum of 300 m paddling distance from knee depth water at low tide mark. The third “apex” buoy shall be placed midway and approximately 15 m seaward of the turning buoys thus forming an arc with them.

The start line need not necessarily be identified, but if required it shall be marked by two poles and positioned so that the center of the start line is aligned with the first turning buoy.

The finish line shall be between 2 flags mounted on stands or poles or other suitable markers in a position where the craft will finish afloat without grounding.

The center of the finish line is usually aligned with the third turning buoy (allowing for prevailing surf conditions). The Finish Flags should be 35 meters apart in knee-deep water on the other end of course.

5.8.3 Dry Start and Dry finish

For a dry start, competitors, with their skis and paddles line up in their drawn positions between two start 2 m poles approximately 5 m from the water's edge and 35 m apart.

At the Starters signal the competitors at their own discretion carry their craft to the water and paddle the surf ski course as per the diagram.

The dry finish line shall be situated on the beach approximately 15 m from the water's edge. It shall be 20 m in length and marked at each end by a flag on a 4 m pole. Finish flags shall be the same color(s) as the course buoys.

- a) Competitors must paddle their surf skis around the last course buoy and shall not be disqualified if they lose contact with or control of their craft or paddle after the last course buoy on the return.
- b) Competitors need not finish with craft or paddle.

- c) The finish is judged on the competitor's chest crossing the finish line. Competitors must finish on their feet in an upright position.
- d) A member of the competitor's team assists with the removal of the competitor's craft and paddle from the course. With the Head Official's approval, non-team members may act as handlers, provided they are registered in the competition in some capacity.
- e) Handlers shall:
 - Wear a competition cap.
 - Wear a distinctive high visibility vest as required by the organizers if entering water beyond knee depth.
 - Make every effort to ensure that they and the equipment they are handling do not impede other competitors (otherwise disqualification may result).
 - Comply with all instructions of the officials.

5.8.4 Equipment

Surf skis: See Section 6 – *Equipment Standards*.

Replacementskis or paddles for a competitor are permitted and may be brought to the water's edge by other Team members providing such replacement does not cause any interference to other competitors in the race and further provided that the competitor shall recommence the race from the original starting area.

5.8.5 Judging

Judges shall be placed to observe the conduct of the event and to determine competitors' place at the finish.

5.8.6 Disqualification

In addition to the *General Rules* the following behavior shall result in disqualification: Failure to complete the course as defined and described.

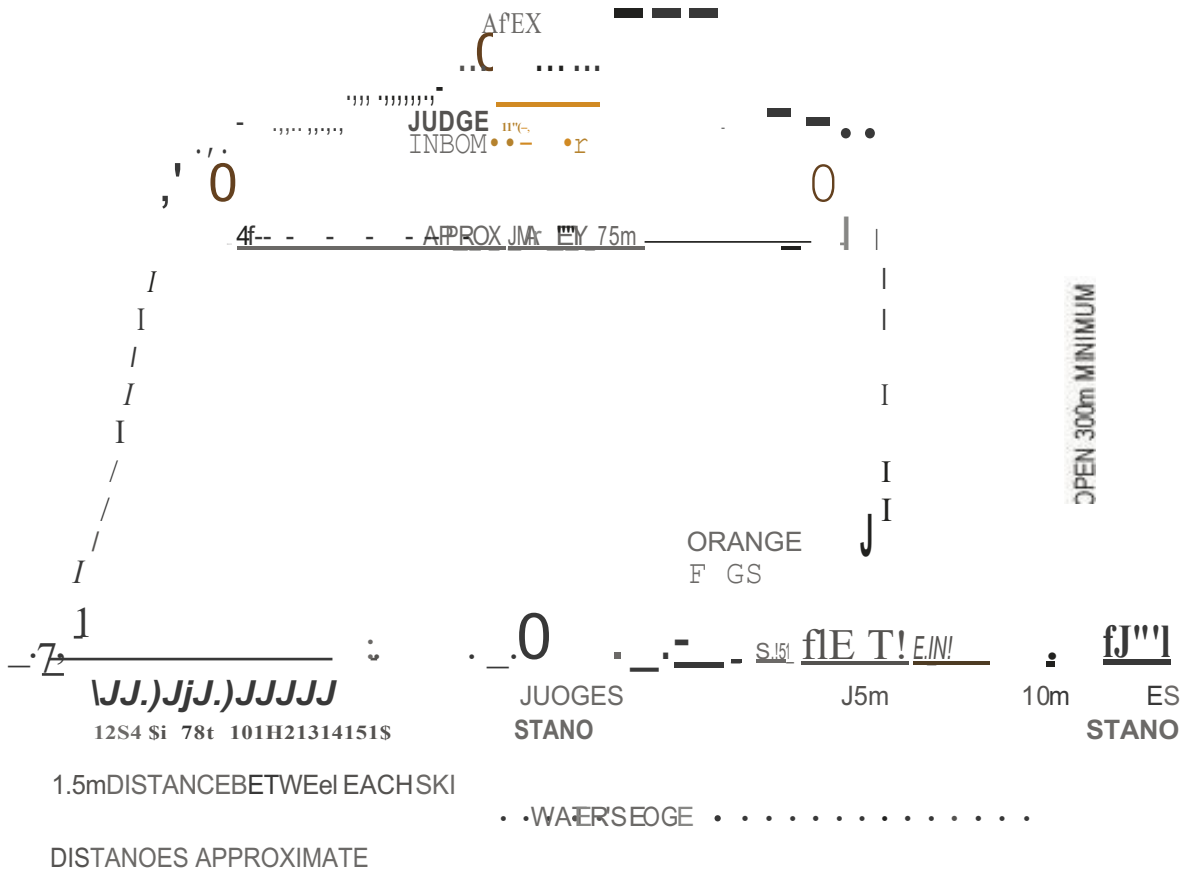

5.8 SURFSKI RACE

5.9 IRONMAN /IRONWOMAN

5.9.1 Event description

Competitors cover a 1.4 km (approx.) course that includes a swim leg, a board leg, a ski leg, and a beach sprint finish.

Except for the differences noted in this section, conditions of racing of each leg are as generally required for the individual conditions of that discipline including the rules governing the component disciplines.

The sequence of legs shall be determined by draw at the commencement of each competition. The same ballot shall determine the order of legs for the Taplin Relay.

If the surf ski leg is first, competitors will start with a typical in-water start.

Starting positions: Competitors must commence craft legs from the correct allotted beach positions.

Competitors must commence craft legs from the correct allotted beach positions.

The starting positions are reversed for the board and ski legs.

For example, in a 16-competitor race in which a competitor has drawn position 1: the competitor commences the initial craft leg from position 1, but commences the other craft leg from position 16.

Competitor's 1st craft leg starting position	1	2	3	4	5	6	7	...16
Competitor's 2nd craft leg starting position	16	15	14	13	12	11	10	...1

Handler:

A member of the competitor's team assists the competitor.

With the referee's approval, a non-team member may act as handler provided he or she is a member of the USLA and is registered to participate at the championships in some capacity.

Handlers shall:

- a) Wear a competition cap identical to that of the competitor.
- b) Wear a distinctive high-visibility vest as required by competition organizers if entering the water beyond knee depth.
- c) Hold the surf ski in a floating position as per the diagram or as directed by officials.
- d) Make every effort to ensure that they and the equipment they are handling do not impede other competitors (otherwise disqualification of the competitor may result).
- e) Comply with all instructions of the officials.

5.9.2 The course

Buoys shall be laid out for the swim, board, and ski legs as indicated in the following diagram.

To ensure fair starts and finishes, alignment of the start line and finish line to the buoys may be altered at the discretion of the referee, depending on the prevailing sea conditions.

Buoy distances:

Swimming buoys shall be positioned at a minimum of 120 m from knee-depth water at low tide mark.

The board leg buoys and ski leg buoys shall be positioned approximately 50 m and 100 m respectively behind the swimming buoys.

The board leg buoys should be approximately 17 m apart and the ski buoys approximately 50 m apart, with the ski "apex" buoy a further 10 m to sea.

Flag layout:

Two flags located approximately 20 m from the water's edge designate beach turning marks. One shall be positioned in line with swim buoy number 2, the other in line with the swim buoy number 9.

Two flags 5 m apart mark the finish line. They are positioned at right angles to the water's edge and approximately 50 m from the first turning flag.

Start and changeover line:

The start and changeover line shall be approximately 30 m in length, centered on the swimming flag buoy number 1 approximately 5 m from the water's edge, and marked by a 2 m high pole at either end.

The start and changeover line serves as a start line if the board or swim leg is first. It serves as a board placement line for the board leg. Competitors are not required to cross the start and changeover line after the race has commenced.

Board course:

The board leg is conducted from the start and changeover line to pass White flag #1 swim buoy on the outside; round the two black and white swim course buoys; return to the beach passing Blue / Yellow #10 swim buoy on the outside; and round the two beach turning flags.

Ski course:

The ski leg is conducted with the skis starting from the ski floating position as per the diagram, around three surfski buoys, return to the beach and run around the two beach turning flags. Competitors must pass on the outside of all buoys. Competitors shall not cut through swim course or board course buoys

Swim course:

The swim leg is conducted from the start and changeover line, around all the swimming flag buoys # 1 to #10, return to the beach and around the two beach turning flags.

Run leg course and finish:

The race shall be concluded when a competitor completes all legs. To finish, a competitor rounds one turning flag, passes the other flag on the shoreward side, and finishes between the two finish flags.

Note: Competitors round the turning flags in the same direction as the Buoys for each leg of the course.

5.9.3 Equipment

Surf skis, paddles, boards: See Section 6 – *Equipment Standards*.

- a) Changing of damaged craft: A board or surf ski shall not be changed during a section of the race unless it is damaged or becomes unseaworthy. Team members/handler shall be permitted to assist in replacing the damaged craft, but only to the extent of placing other craft at the start and changeover line.
- b) Paddles: A lost or damaged paddle may be replaced only after the competitor returns to the start and changeover line.
- c) Equipment removal: To assist with the safe conduct of the event, team members and/or handlers may remove damaged or abandoned equipment from

Control of craft: Competitors must be in control of the ski or board up to and including the last course buoy. Competitors shall not be disqualified if they lose control of the craft on the return journey from the buoys. Competitors may lose control on the way out without penalty provided They regain the craft and round the last turning buoy of each leg in control of the craft and complete the course.

5.9.4 Judging

The finish is judged on the competitor's chest crossing the finish line.

Competitors must finish on their feet in an upright position. Judges shall be placed to observe the conduct of the event and to determine competitors' place at the finish.

5.9.5 Disqualification

In addition to the *General Rules* the following behavior shall result in disqualification: Failure to complete the course as defined and described.

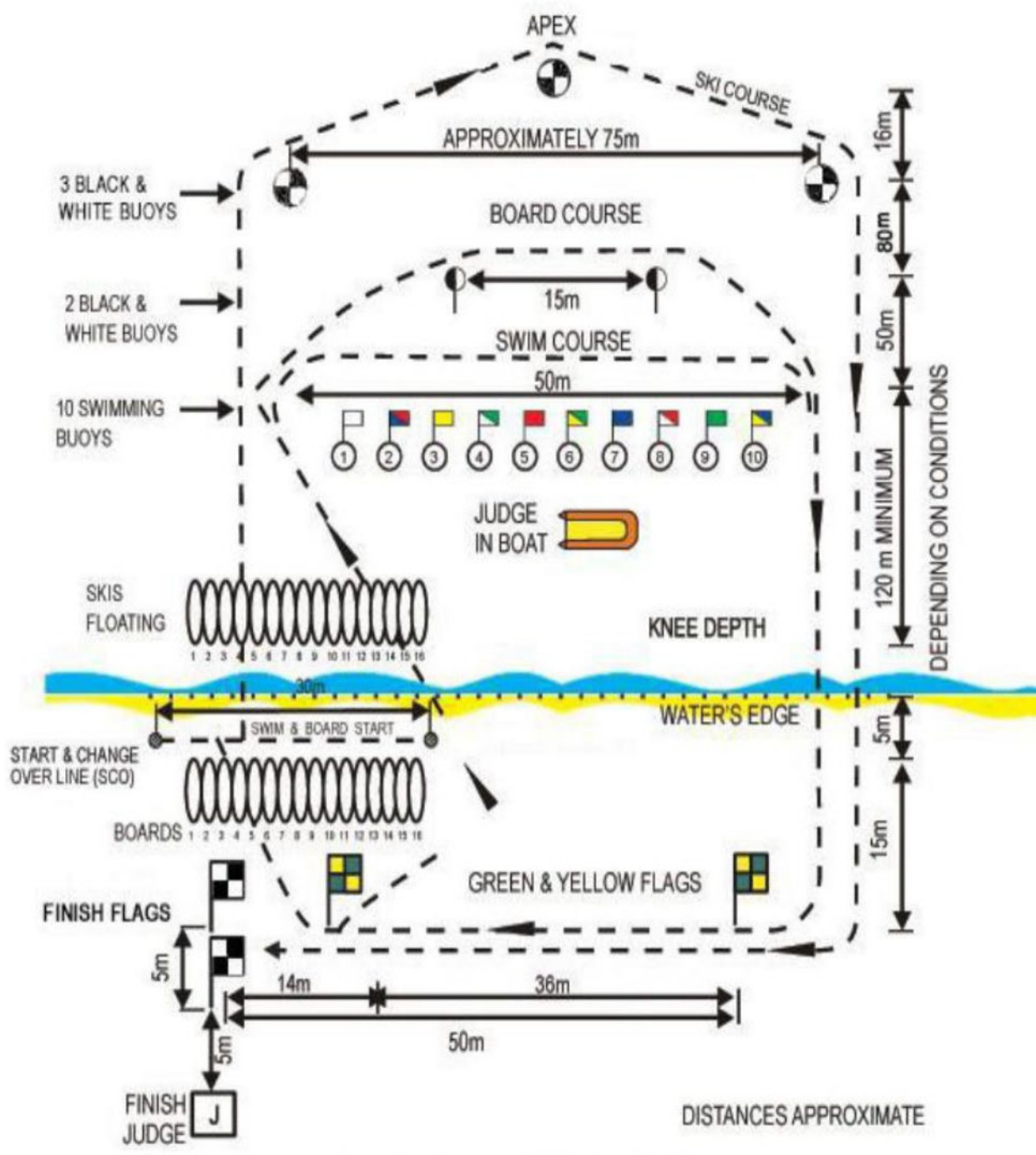

5.9 IRONMAN / IRONWOMAN

5.10 AMERICAN IRONMAN / AMERICAN IRONWOMAN

5.10.1 Event Description

Competitors cover a 1400 m (approx.) course that includes a swim leg, a board leg, a solo surfboat leg, and a beach sprint finish.

Conditions of racing each leg are as generally required for the individual conditions of that discipline including the rules governing the component disciplines: surfboats, board races, surf races, beach sprints.

The sequence of legs shall be determined by draw at the commencement of each competition at least one hour prior to the race. The same ballot shall determine the order of legs for the Ironman and Taplin Relay.

If the surf boat leg is first, competitors will start with a typical Surfboat start with a handler.

5.10.2 Starting positions:

Competitors must commence craft legs from the correct allotted beach positions. The starting positions are reversed for the board and surfboat legs. For example, in a 16-competitor race in which a competitor has drawn position 1: the competitor commences the initial craft leg from position 1 but commences the other craft leg from position 16.

Handler:

A member of the competitor's team assists the competitor. With the referee's approval, a non-team member may act as handler provided he or she is a member of the USLA and is registered to participate at the championships in some capacity.

Handlers shall:

- hold the surfboat in a floating position as per the diagram or as directed by officials; and:
- wear a cap identical to that of the competitor.
- make every effort to ensure that they and their craft do not impede other competitors (otherwise disqualification may result).

5.10.3 The course

Buoys shall be laid out for the swim, board, and surfboat legs as indicated in the following diagram.

To ensure fair starts and finishes, alignment of the start line and finish line to the buoys may be altered at the discretion of the referee, depending on the prevailing sea conditions.

Buoy distances: Swimming buoys shall be positioned at a minimum of 120 m from knee-depth water at low tide mark. The board leg buoys, and surfboat leg buoys shall be positioned approximately 50 m and 130 m respectively behind the swimming buoys. The board leg buoys should be approximately 15 m apart and the surfboat buoys approximately 75 m apart, with the surfboat "apex" buoy a further 16 m to sea.

Flag layout: Two flags located approximately 20 m from the water's edge designate beach turning marks. One shall be positioned in line with swim flag buoy #2, the other in line with the swim flag buoy #9.

Two flags 5 m apart mark the finish line. They are positioned at right angles to the water's edge and approximately 60 m from the first turning flag.

Start and changeover line: The start and changeover line shall be approximately 30 m in length, centered on the swimming flag buoy number 1 approximately 5 m from the water's edge, and marked by a 2 m high pole at either end.

The start and changeover line serves as a start line if the board or swim leg is first. It serves as a board placement line for the board leg. Competitors are not required to cross the start and changeover line after the race has commenced.

Swim Course: Swim clockwise approximately 250 meters around the two center swim flag buoys (Red #5 to Green/Yellow #6).

Board course: Board paddle approximately 400 meters clockwise from the start and changeover line to pass White flag buoy #1 on the outside; round the two black and white swim course buoys; return to the beach passing Blue/Yellow flag buoy #10 on the outside; and round the two beach turning flags.

Solo Surfboat Course: Row a Surfboat clockwise around the three buoy apex course. Competitors must pass on the outside of all buoys. Competitors shall not cut through swim course or board course buoys.

Beach sprint course and finish: The race shall be concluded when a competitor completes all legs. To finish, a competitor rounds one turning flag, passes the other flag on the shoreward side, and finishes between the two finish flags.

Note: Competitors round the turning flags in the same direction as the buoys for each leg of the course.

Competitors can drop crafts in knee-deep water and continue race. Handlers must remove craft from finish area. Handlers must not interfere with another competitor. If they do, their competitor is subject to disqualification.

5.10.4 The start

SWIM: Start behind line, minimum 5 meters from water's edge, directly in front of middle swim buoy.

BOARD: Start minimum 5 meters from water's edge behind line.

SURFBOAT: Start minimum 5 meters from water's edge behind line. Run down to surfboat already in surf. Helmets are required to be worn during surfboat leg.

5.10.5 The finish

Shall be between two flags and into a funnel at the end of a 50-meter run. Competitors must cross the finish line in an upright position.

5.10.6 Equipment

All boards and boats shall conform to USLA Rules. Handlers must wear a Team Competition Cap.

Equipment removal: To assist with the safe conduct of the event, team members and/or handlers may remove damaged or abandoned equipment from the course during the event provided the progress of other competitors is not obstructed.

5.10.7 Judging

The finish is judged on the competitor's chest crossing the finish line.

Competitors must finish on their feet in an upright position.

Judges shall be placed to observe the conduct of the event and to determine competitors' place at the finish.

5.10.8 Disqualification

In addition to the General Rules the following behavior shall result in disqualification: Failure to complete the course as defined and described.

Control of craft: Competitors must be in control of the surfboat or board up to and including the last course buoy. Competitors shall not be disqualified if they lose control of the craft on the return journey from the buoys. Competitors may lose control on the way out without penalty provided they regain the craft and round the last turning buoy of each leg in control of the craft and complete the course.

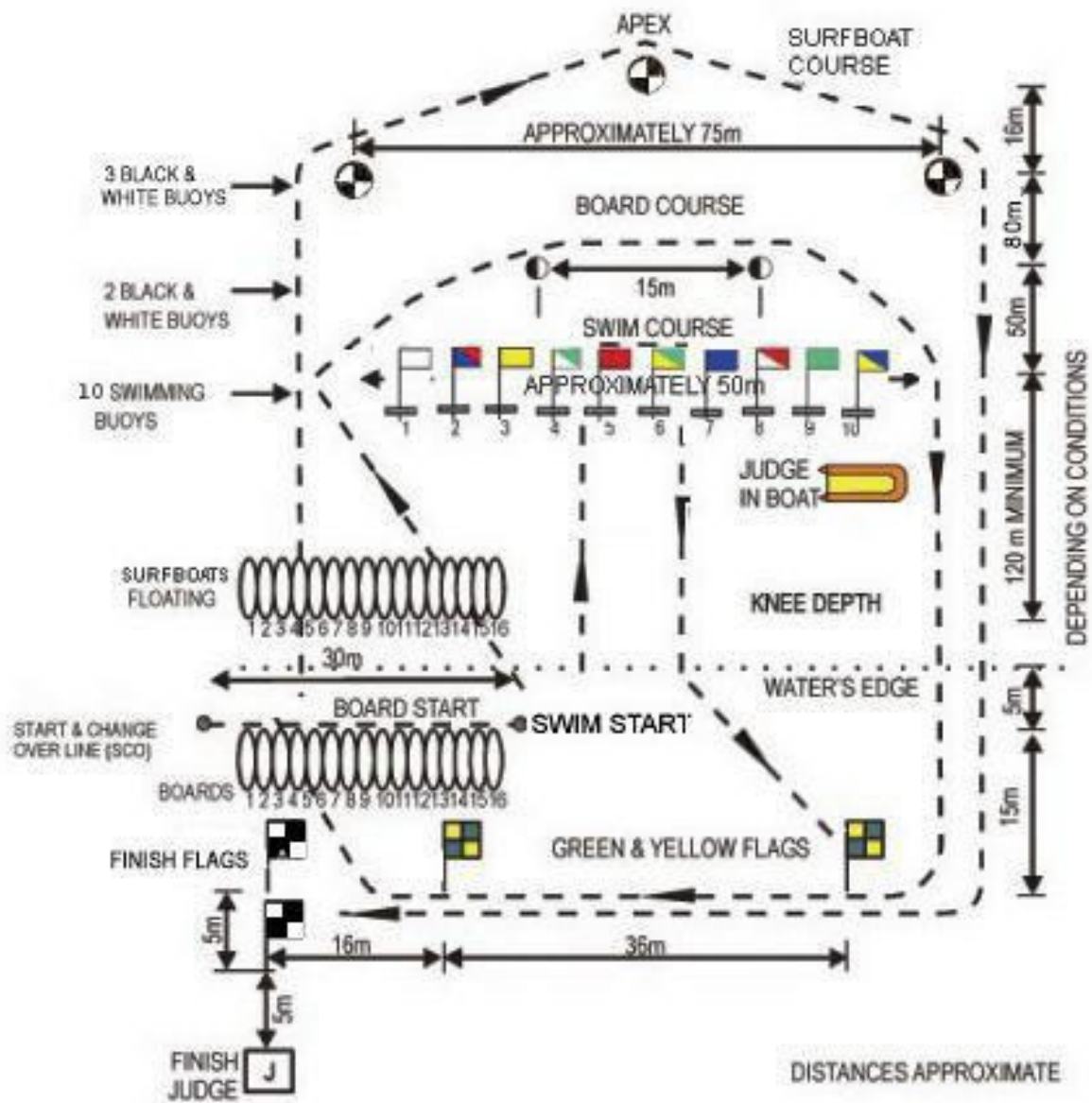

5.10 AMERICAN IRONMAN

5.12 BEACH FLAGS

5.12.1 Event description

From a prone starting position on the beach, competitors rise, turn and race approximately 20 m (15 m for Masters) to obtain a baton (beach flag) buried upright in the sand with about two-thirds showing. Since there are always fewer batons than competitors, those who fail to obtain a baton are eliminated.

Starting position

Competitors take their allotted positions, a minimum of 1.5 m apart at the start line.

Competitors lie face down with their toes on the start line with heels or any part of the feet together, hands on top of each other with fingertips to wrists and with the head up.

Elbows should be extended 90 degrees to the body's midline and hips and stomach must be in contact with the sand.

The body's midline should be 90 degrees to the start line.

*Note 1: Competitors may level, flatten, and compress their starting area. Competitors are not permitted to create mounds or unreasonably alter the incline of the sand to assist the start.

*Note 2: Competitors may dig their toes into the sand at the start line by digging with their hands or feet before lying on the sand, or with their feet after lying on the sand.

*Note 3: Competitors must comply with the direction of officials. A competitor who causes unreasonable delay to the start of the event may be penalized.

5.12.1 Start procedure

Beach Flags start procedure is different from the procedure described in 4.2 "The Start".

For Beach Flags, the start is as follows:

Prior to the start, a Marshal shall:

- a) Place competitors in the order as drawn for the run-through.
- b) Accompany competitors to the starting area to ensure they are positioned in proper order.

The Chief/Sectional Referee shall:

- a) Check that all technical officials and equipment are in position.
- b) Signal the official start of each race with a long whistle indicating that the competitors should take their positions on the start line.
- c) Signal the Starter that the competitors are under the Starter's control.
- d) The Starter shall be positioned out of view of the competitors.

5.12.2 The start

- a) On the Starter's "Competitors Ready" command, competitors shall assume the starting position as described.
- b) On the Starter's "Heads Down" command, competitors – at once and without delay – shall place their chins on their hands.
- c) After a deliberate pause and when all competitors are stationary, the Starter shall signal the start with a whistle blast.
- d) At the start signal, competitors shall rise to their feet and race to obtain a baton.

5.12.3 Starting infringements

The following behaviors are starting infringements in Beach Flags:

- a) Failure to comply with the starter's commands within a reasonable time.
- b) Lifting any part of the body from the sand, or commencing any starting motion after the starter's "Heads down" command and prior to the start signal.

If a competitor is disqualified or eliminated, the remaining competitors and batons shall be realigned with no re-draw of positions. The run-through shall continue with the current starting infringement in force until a fair start has occurred.

5.12.4 Draw for positions

There shall be a preliminary draw for positions and further draws after each round. In semi-finals and finals when contestants have been reduced to eight, there shall be a draw for positions after each run-through.

5.12.5 Number of competitors eliminated

In heats, the Head Official shall determine whether one or two competitors are to be eliminated in each run-through.

In semi-finals (final 32) and finals (final 16), no more than one competitor can be eliminated in any run-through.

5.12.6 Run-offs

A run-off between the competitors involved shall be called if two or more competitors hold the same baton, and judges cannot determine which competitor's hand grasped the baton first – regardless of the hand position on the baton.

Likewise, a run-off between the competitors involved shall be called if a baton is "lost" in the sand. If it is apparent that a baton has been "lost" to competitors in the sand, the finish judge shall signal (by whistle or verbally) that the baton is "lost" and that the run-through is finished.

5.12.7 The course

As shown in the following diagram, the course shall be approximately 20 m from the start line to the batons, and wide enough to provide for a minimum spacing of 1.5 m between each of up to 16 competitors.

The start line shall be designated at each end by poles, 2 m high.

Batons shall be positioned in line parallel to the start line, and so that a "perpendicular line" between any two adjacent competitors shall pass approximately through a baton. In other words, batons are aligned on the baton line equidistant between adjacent competitors.

The Beach Flags arena should be free of debris, and if the sand surface is hard, it should be raked to make it safer before and throughout the competition.

5.12.8 Equipment and apparel

Beach flags (batons): See Section 6 – *Equipment Standards*. Shorts and shirts, which comply with team uniform requirements, may be worn at the competitors' discretion.

5.12.9 Judging

The referee or referee's appointee shall be positioned to maintain overall supervision. The starter and start judges shall be placed at either end of the starting line to observe any starting infringements. Course judges shall be placed on either side of the course to observe run-throughs and participation infringements.

Finish judges shall be positioned a few meters behind the line of batons, to reclaim the baton from successful competitors and to set up the batons for the next run-through.

5.12.10 Elimination and Disqualification

Each run-through or run-off shall be judged as a separate segment of this event. An infringement in one segment shall not be carried over and counted against a competitor in a subsequent segment.

A competitor who commits a starting infringement or who impedes the progress of another competitor shall be eliminated (not disqualified).

A competitor *eliminated* from the event shall retain the point score and/or placing as at the time in the event. However, a competitor *disqualified* from the event shall lose all standing from the event.

In Beach Flags events a protest against an elimination must be lodged within 5 minutes or before the next run through of an event begins (whichever occurs first).

If a Beach Flag elimination protest occurs the Head Official will immediately consider the protest without delay before proceeding with the event. There will be no Appeal permitted on Beach Flag elimination protest decisions of the Referee.

*Note 1: The Head Official is authorized to refer a Beach Flag elimination protest directly to an on-beach Protest Committee representative for decision on the basis of the processes and timings detailed above. No paperwork is required nor is a fee payable if this occurs.

*Note 2: A competitor is permitted to protest and/or appeal against a disqualification decision in Beach Flag events provided that correct processes are followed as detailed in Section 2 of this Manual.

Impedance:

Impedance is defined as “the use of hands, arms, feet or legs to impede another competitor’s progress”.

A competitor may otherwise use his or her body to improve his or her position in obtaining a baton. A competitor may negotiate the shoulder and or body in front of an opponent, but may not use hands, arms, feet or legs to obtain or remain in this position.

If a competitor legally obtains this front position and maintains normal running action, the competitor behind is obliged to go around the competitor in front.

A competitor may cross over in front of a slower competitor.

If two or more competitors are guilty of impedance, the competitor who first used hands, arms, feet or legs may be eliminated.

Notwithstanding the impedance clauses, if it is deemed that the competitor has breached the Code of Conduct and/or competed unfairly the competitors involved may be disqualified.

In addition to the *General Rules* the following behavior shall result in disqualification:

- a) Failure to complete the event as described and defined.
- b) Deliberately impeding the progress of another competitor.
- c) Picking up more than one baton. – e.g., lying on a baton or covering a baton from sight.

BEACH FLAGS

AGE GROUP	DISTANCE
Open	20 m
Masters	15 m

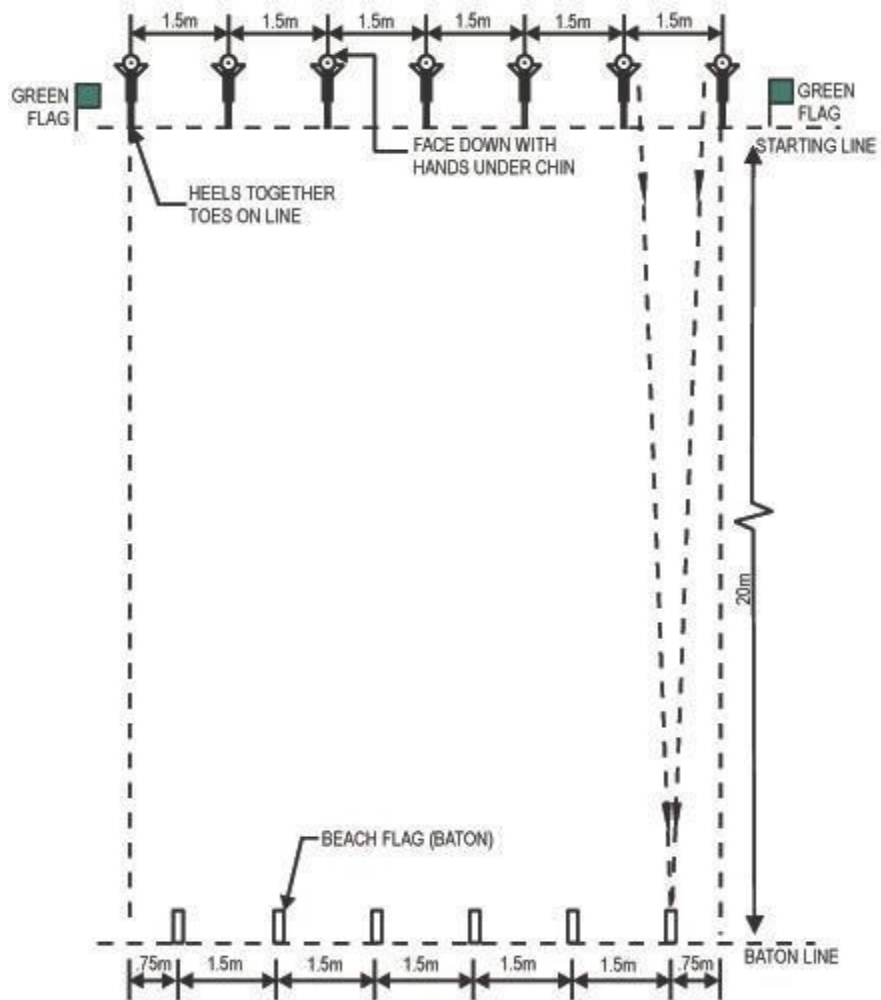

5.12 BEACH FLAGS

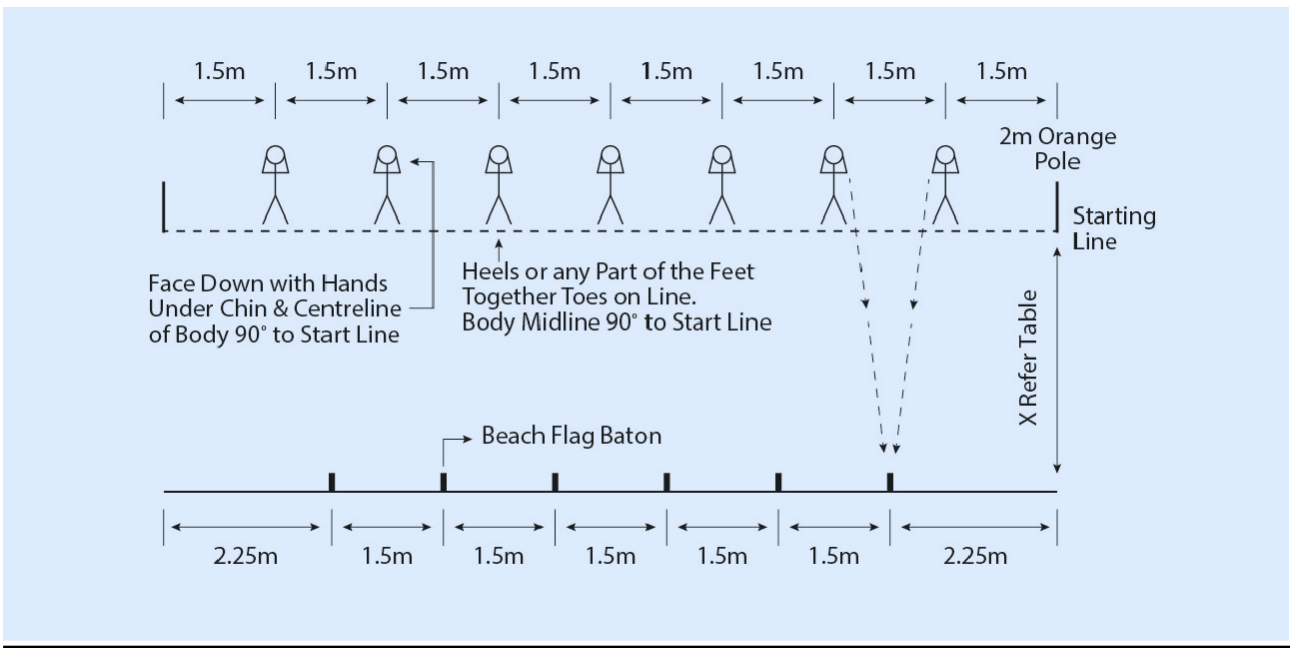
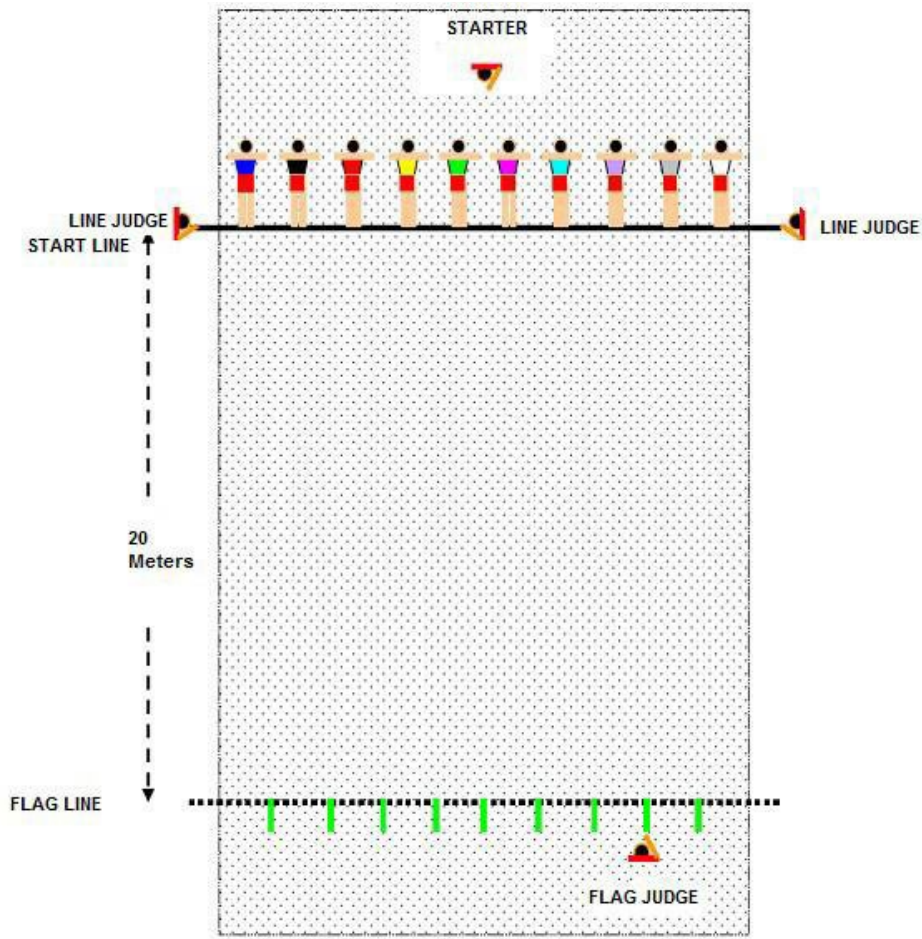

5.13 BEACH SPRINT (90m)

5.13.1 Event description

Competitors take their positions in their allotted lanes. At the starting signal, competitors race the 90m course to the finish line. The finish is judged on the competitor's chest (only) crossing the finish line. Competitors must finish the event on their feet in an upright position.

*Note: Maximum entry of 4 men & 4 women per USLA chapter.

5.13.2 The start

No artificial starting blocks are permitted, but competitors may create holes and/or hillocks in and of sand to aid their start. Competitors are not permitted to use any material other than sand to aid the start. Competitors are permitted to flatten or level the sand in their lanes.

5.13.3 The course

As shown in the following diagram, the beach sprint course shall be 90m from the start line to the finish line.

An area of approximately 20m is to be provided at the start end for marshalling and at the finish end for competitor overrun. The course shall be rectangular and "squared" to ensure that all competitors run the same distance, and it shall be designated by four distinctly colored poles, 2 m high.

Running lanes separated by colored ropes shall be laid on the beach to assist runners in keeping a straight course. The lanes shall be laid 1.8 m in width where possible with a minimum width of 1.5m. Competitors must remain in their own lane throughout the course.

Numbered pegs identifying running lanes shall be placed before the starting mark and beyond the finishing line.

A marshalling line shall be made 5m to the rear and parallel to the starting mark and designated by poles 2 m high.

5.13.4 Equipment and apparel

Shorts and shirts, which comply with team uniform requirements, may be worn at the competitors' discretion. Competitors may be required to wear colored bibs to assist in judging.

5.13.5 Judging

The Chief Referee/Sectional Referee shall be positioned to maintain overall supervision. Two Course Judges shall be appointed to ensure the competitors run the course as described. Finish Judges shall select placings. The competitors shall be placed in the order in which any part of their chest crosses the finish line. Competitors must cross the line on their feet in an upright position.

5.13.6 Disqualification

In addition to the General Rules in Section 2 and General Conditions for ocean competition, the following behavior shall result in disqualification:

- a. Failure to complete the course as defined and described.

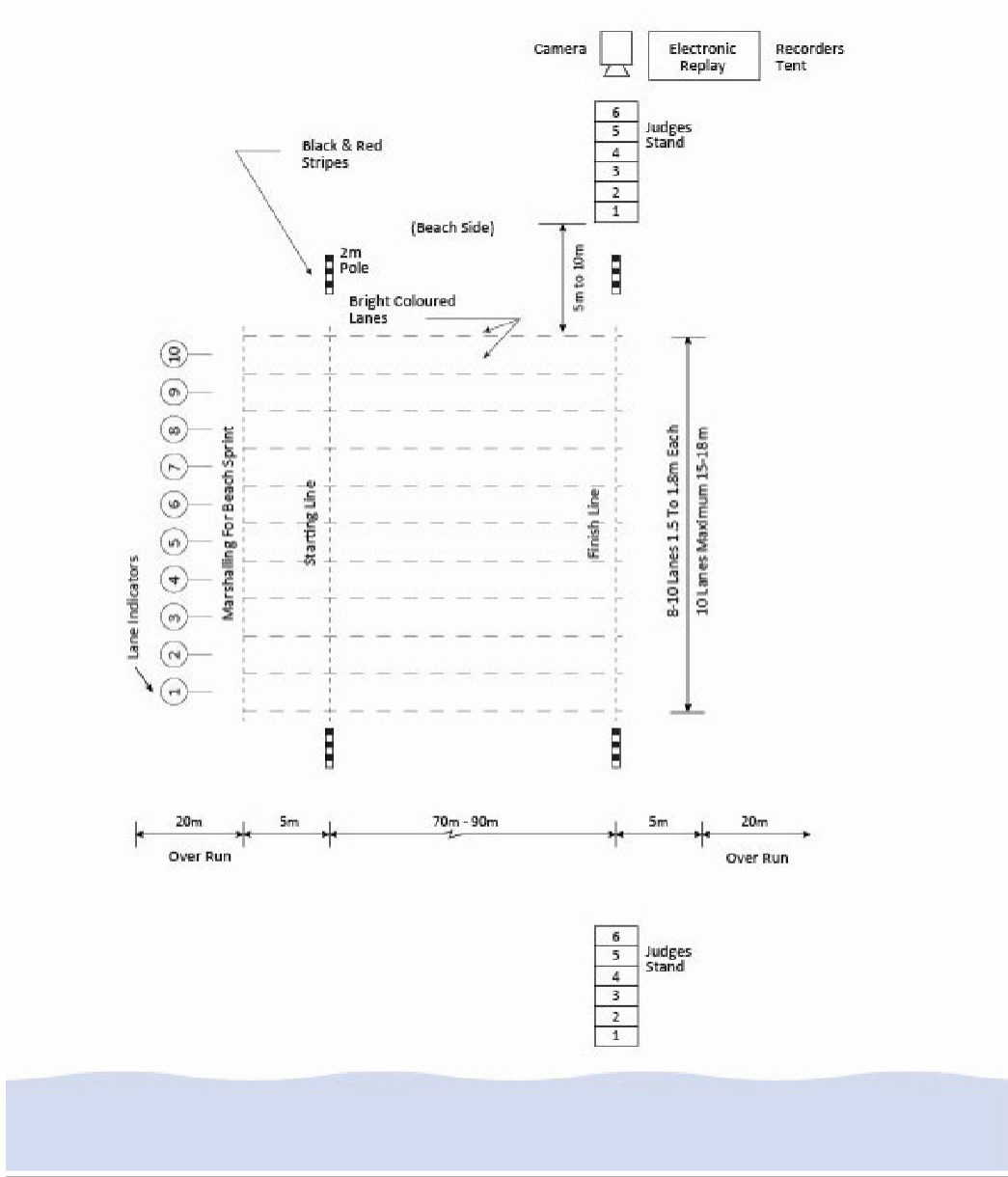

5.14 BEACH RUN-2 km

5.14.1 Event description

Competitors race 2 km on the beach.

The course design shall maintain the total distance and be set based on the venue's features.

The default lap distance is 500 meters.

The Head Official may set a 1 km lap distance on beaches with more room.

On the starting signal competitors race along the left side of the lane to round (clockwise or right hand in) the turning poles 250 m distant and return 250 m toward the start/turn flags.

Competitors round all turning flags (clockwise or right hand in or as otherwise advised by the Referee) at the start/turn line, proceed back down the beach to round the turning flags as before and repeat four times.

On the last lap competitors cross the finish line to complete the race.

Deliberately jostling or obstructing another competitor so as to impede his or her progress is not permitted.

Judges shall be placed to observe the conduct of the event as well as determine competitors'

The finish is judged on the competitor's chest crossing the finish line. Competitors must finish on their feet in an upright position.

5.14.2 The course

The course (as shown in the following diagram) shall be laid out on the beach (on soft sand where practical) parallel to the water's edge.

The start line shall be designated by a line in the sand or a brightly colored synthetic cord stretched between two poles with green and yellow flags attached.

The finish line shall be two green flags placed approximately five meters apart and on the shoreward side of the start/turn line. The Head Official shall determine the length of the start/turn line.

Running lanes: The course shall be divided into 2 lanes parallel to the waterline. The lane closest to the water shall be for legs running from the start/finish lines. The lanes shall be divided by colored tape, bunting, or other appropriate material.

*Note: Should the course be run in the reverse direction the outwards legs shall be on the shoreward side and the return legs on the water side.

Two poles with green and yellow flags attached approximately five meters apart and situated approximately 250 m from the start at the end of the lane divider shall designate the turning point.

5.14.3 Equipment and apparel

Shorts and shirts, which comply with team uniform requirements, may be worn at the competitors' discretion. All competitors must wear beanies with appropriate team colors. Shoes are optional.

5.14.4 Judging

The referee shall be positioned at one side of the course to maintain overall supervision.

Course judges may be appointed to ensure the competitors run the course without interference to other competitors.

A judge shall be positioned at each turning pole to ensure no unnecessary jostling or interference occurs.

Finish judges shall select final placings.

5.14.5 Disqualification

In addition to the General Rules the following behavior shall result in disqualification: Failure to complete the course as defined and described.

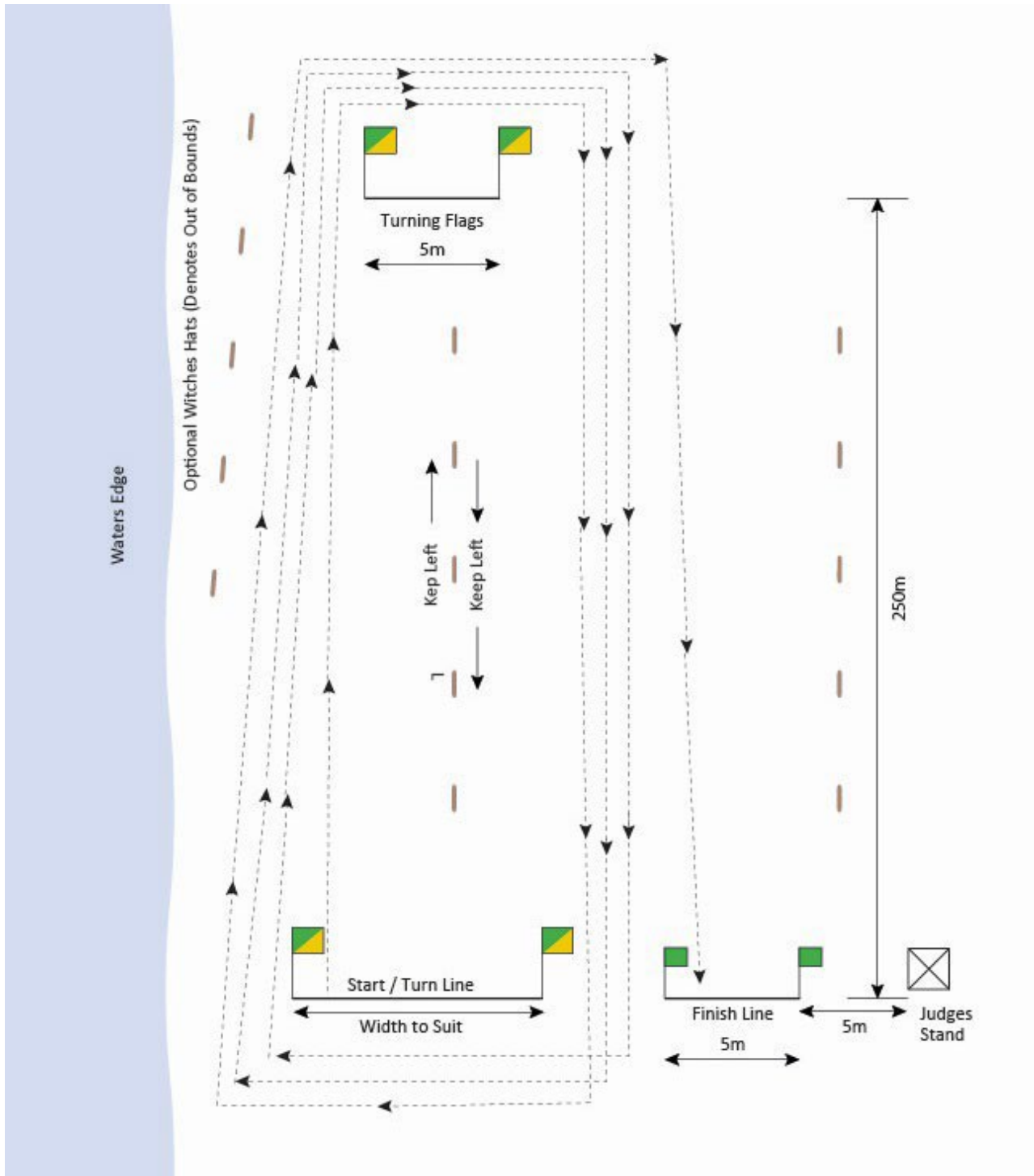

International Life Saving Federation 2km Beach Run course set up

5.15 SOLO SURFBOAT RACE

5.15.1 Event Description

A Surfboat with a single rower on board shall row around the three outside Surfboat/Surfski buoy courses returning to shore where they disembark from the boat and run up to and across the finish line.

Solo Surfboat will be one clockwise lap. One lap is approximately 700 meters long.

Competitors may lose contact and control of their surfboat without necessarily being disqualified.

Competitors are not permitted to hold or otherwise interfere with other competitors' surfboat or deliberately impede their progress during the race.

5.15.2 The Course

The Solo Surfboat Race shall row clockwise around all three Surfboat/Surfski course buoys. 10 surfboats per heat shall be allowed. Lane placement of all rowers shall be determined by random draw prior to start of the race. The center lane will be established prior to the race. Surfboats will be positioned equally on both sides of the center lane. Lane 1 will be the lane furthest to the left looking seaward. Two handlers in helmets are allowed to hold the boat steady.

To ensure fair starts and finishes, alignment of the start line and finish line to the buoys may be altered at the discretion of the referee, depending on the prevailing sea conditions.

5.15.3 Equipment

Surfboats shall conform to the USLA specifications.

Helmets shall be worn by all rowers and handlers.

Note-Special Instructions for the Officials:

The Clerk-of-the-Course shall be responsible for the check-in of all registered rowers at the race site. He shall use a public address system to call all participating surfboat rowers together 45 minutes prior to the beginning of the race. At the pre-race meeting the clerk will explain the course, the starting commands, and conduct the draw for lanes. The clerk should conduct the lane draw for each heat at the pre-race meeting. After that there should be no more meetings or lane draws.

Any rower not present for the lane draw will be disqualified.

Crews may not be permitted to start in an event if they are late reporting to the marshalling area. Under certain mitigating circumstances, such as being involved with another competition, the Course Clerk has the right to waive the disqualification, provided that prior notification has been given.

5.15.4 The Start

The Starter shall stand in the direct center of the starting line of surfboats, in a position to be clearly visible to all participants, and by use of an audio hailer indicate to the rowers that the race is about to begin.

The Starter issues the part start command "Take your Marks" and the rowers will line up with feet behind the startline.

The "Set" command may be either a verbal "Set" or "Rowers, you are in the Starters Hands", or an official holding a signal flag aloft to indicate that a start is imminent.

The start ("Go") signal is then given by such means as a starting gun, air horn, whistle, or other appropriate means.

At any time following that "Set" command, the gun may be fired.

The Two handlers must be out of the surfboat and must hold the boat stationary.

At the sounding of the Starter's signal the handler may hold, but not advance the surfboat.

The rower must be behind the starting line until the Starter's signal.

After the starter signal, the rower may hasten to run down the berm and jump into the surfboat and proceed with the race.

There shall be no "holder-pusher." The 2 handlers responsibility is to steady the boat until the rower has extended both oars and has control of their boat. The 2 handlers may not push or advance the boat once the rower has oars out. The handler may not impede another boat.

5.15.5 The Race

The surfboats will proceed through the surf until reaching the first buoy. They will round it clockwise and continue over the designated 3 buoy course rounding each buoy clockwise and return to the beach.

5.15.6 The Finish

At the completion of the lap, the solo surfboat rower must pass around the last buoy and row to the beach to complete the lap under control and properly equipped.

The rower must not leave the surfboat and run up the beach until a handler, wearing a helmet, has control of the boat, then the rower may leave the boat and run through the funnel finish in an upright position.

Note 1: "Under control" is defined as a boat being in an upright position with crew in contact with the boat and the boat moving in a direction towards the finish line.

Note 2: "Properly equipped" to complete a finish is defined as a boat equipped with a rescue tube, a minimum of two rowing oars which shall be in the boat or in the rowlocks.

As an alternative to the above, there is also an option for dry starts and finishes in any combination with wet starts and wet finishes.

A. A wet finish placing shall be determined when any part of the hull of the boat crosses the finish line under control of the crew and properly equipped from the seaward side between the finishing flags or when a boat runs aground. The crew may recover a boat that has crossed the finish line not under the control and/or properly equipped and then again cross the finish line correctly to record a finish placing result. The finishing line shall be a line of sight drawn between two flags as determined by the Chief Referee on poles positioned far enough apart to allow all boats to finish afloat.

In some circumstances a video finish line will be used. In these cases, the finish line will be the line of sight between the video cameras, but the competition area will still be marked by the flags or poles. The Surf Boat Referee will inform competitors when the video is being used as the finish line.

Note 3: Where video cameras are used to assist with the judging process the judging (finish) line may be modified to accommodate the optimum use of such technology e.g., rigid poles without flags may be used. The standard finish flags may then be placed on the shoreward side of the rigid judging line poles and as close as practical to the rigid judging line poles. Boats are expected to proceed past the judging line and through the finish flags to complete a race.

B. A dry finish is determined when a crew member leaves the boat and runs to the finish line and crosses the line upright and in control. The crew member may leave the boat at any time after the last turn has been completed and must cross the line while remaining in an upright position on their feet.

C. An alternate to crossing the line to finish may be prescribed by the Chief Referee. In such circumstances, the crew member leaves the boat as described and then is required to touch the crew's finish marker while remaining on their feet.

D. Any boat that dislodges the judging crew in a wet finish so as to impede judging shall be disqualified. If one boat causes another boat to dislodge the judging stand, the matter shall be adjudicated by the Chief Referee.

When it is not possible to provide a fair course over the full number of positions, the Chief Referee, at their discretion, may reduce the number of crews in each race, including the finals to improve the fairness of racing.

5.15.7 Equipment removal

To assist with the safe conduct of the event, team members and/or handlers may remove damaged or abandoned equipment from the course during the event provided the progress of other competitors is not obstructed. All assistance other than rescue related in providing replacement oars, etc. must be done behind the startline/finishline.

5.15.8 Judging

The dry finish is judged on the competitor's chest crossing the finish line.

Competitors must finish on their feet in an upright position.

Judges shall be placed to observe the conduct of the event and to determine competitors' place at the finish.

5.15.9 Disqualification

In addition to the General Rules the following behavior shall result in disqualification: Failure to complete the course as defined and described.

5.15.10 Control of craft

Competitors must be in control of the surfboat up to and including the last course buoy. Competitors shall not be disqualified if they lose control of the craft on the return journey from the buoys.

Competitors may lose control on the way out without penalty provided they regain the craft and round the last turning buoy in control of the craft and complete the course.

At least one handler must remain with the Surfboat and attempt to maintain control of the Surfboat until after the solo rower has passed through the funnel and ran across the Finish line.

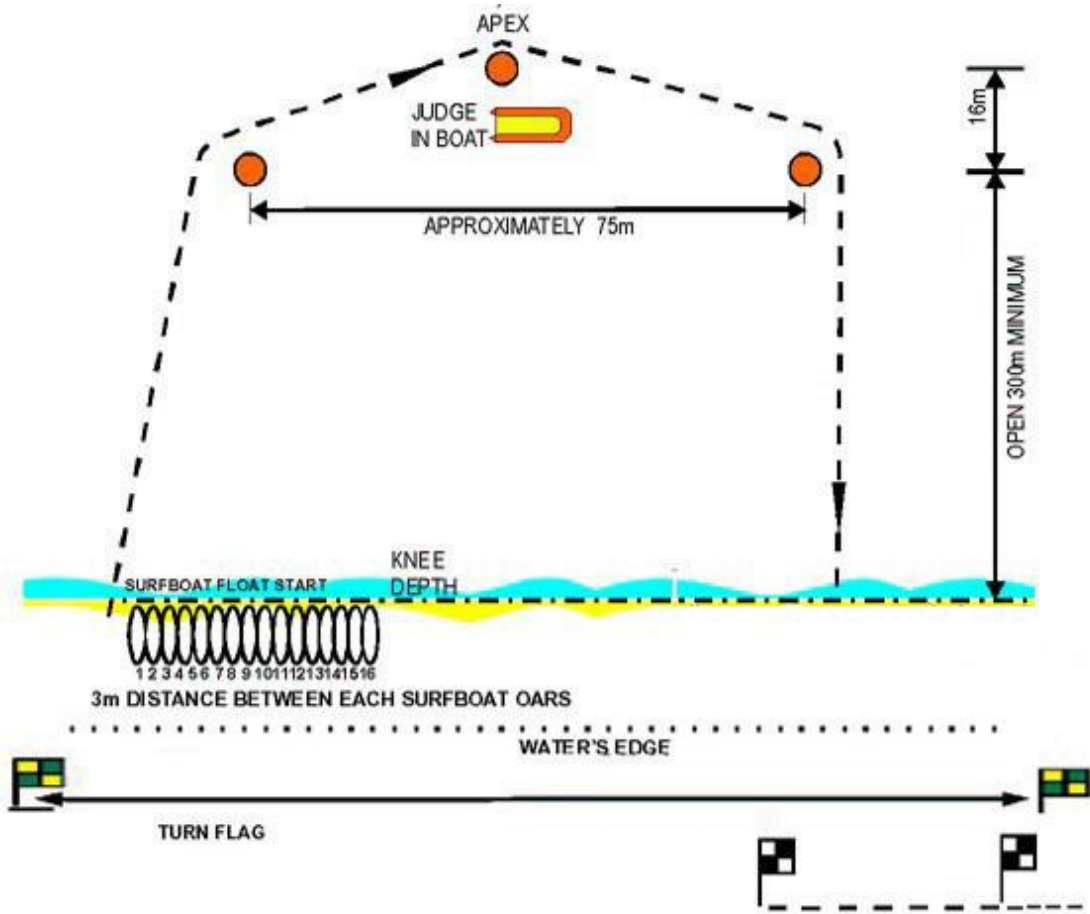

5.14 SURF BOAT RACE

5.16 SURFBOAT RACE

5.16.1 Event Description

Two-person Surfboat teams row around the three outside Surfboat/Surfski buoy courses returning to shore where one member disembarks from the boat and runs up to the touch line. Once across the touchline the member can return to their surfboat for a second lap, repeating the touch line run. At the finish of the third lap one member must leave the boat and run up to and across the finish line.

Three lap races are approximately 2000 meters, two laps are approximately 1300 meters, one lap is approximately 665 meters.

Open Men and Open Women will be three laps.

Mixed Surfboat and Men's Masters events 30-34, 35-39, 40-44, 45-49 will be two laps only. Events will start and finish at the finish line area. Same as lap two and lap three are run in the Open event.

Solo Surfboat, Masters Women 30+, and Men's 50+ will be one clockwise lap.

Competitors may lose contact and control of their surfboat without necessarily being disqualified.

Competitors are not permitted to hold or otherwise interfere with other competitors' surfboat or deliberately impede their progress.

5.16.2 The course

The Surfboat Race shall row round all three Surfboat/Surfski course buoys three times beginning on the left side of the course. First lap is clockwise, second lap counterclockwise, third lap is clockwise.

10 surfboat teams per heat shall be allowed. Lane placement of all teams shall be determined by random draw prior to start of the race. The center lane will be established prior to the race. Surfboats will be positioned equally on both sides of the center lane. Lane 1 will be that lane furthest to the left looking seaward.

To ensure fair starts and finishes, alignment of the start line and finish line to the buoys may be altered at the discretion of the referee, depending on the prevailing sea conditions.

5.16.3 Equipment

Surfboats shall conform to the USLA specifications. Helmets shall be worn by all rowers.

Special Instructions for the Officials

The Clerk-of-the-Course shall be responsible for the check-in of all registered rowers at the race site. He shall use a public address system to call all participating surfboat crews together 45 minutes prior to the beginning of the race. At the pre-race meeting the clerk will explain the course, the starting commands, and conduct the draw for lanes. The clerk should conduct the lane draw for each heat at the pre-race meeting. After that there should be no more meetings or lane draws. Any crew which does not have at least one of its members present for the lane draw will be disqualified.

Under certain mitigating circumstances, such as being involved with another competition, the Course Clerk has the right to waive the disqualification, provided that prior notification has been given.

5.16.4 The Start

The Starter shall stand in the direct center of the starting line of surfboats, in a position to be clearly visible to all participants, and by use of an audio hailer indicate to the rowers that the race is about to begin.

The Starter issues the command "Take your Marks".

The "Set" command may be either a verbal "Set" or "Rowers, You are in the Starters Hands" or an official holding a signal flag aloft to indicate that a start is imminent.

The start ("Go") signal is then given by such means as a starting gun, air horn, whistle, or other appropriate means.

At any time following that command, the gun may be fired.

The Starter will serve as an Official Judge of touch lines and the funnel finish, and may enlist additional judges, as they are needed.

The bowman must be out of the surfboat and must hold the boat stationary.

At the sounding of the Starter's pistol the bowman may enter the surfboat.

The stern man must be behind the starting line until the Starter's gun is fired.

At that time, he may hasten to join his partner in the surfboat and proceed with the race. There shall be no "holder-pusher."

5.16.5 The Race

The surfboats will proceed through the surf until reaching the first buoy. They will round it and continue over the designated buoy course until they return to the beach.

Upon reaching the surfline, one member of each crew must leave the surfboat and run up the beach to the touch line. Any part of their body may make contact, after which they may return to the surfboat to begin their second lap. The touch line shall be a continuous imaginary line between two specified points.

The second lap travels in reverse of the first lap, and the same procedure is required for the completion of lap two.

5.16.6 The Finish

At the completion of the third lap, the surfboat must pass the last buoy, after which time any member of the crew may complete the lap.

One member of the crew must leave the surfboat and run up the beach, and pass through the funnel finish in an upright position.

5.16.7 Equipment removal

To assist with the safe conduct of the event, team members and/or handlers may remove damaged or abandoned equipment from the course during the event provided the progress of other competitors is not obstructed. All assistance other than rescue related in providing replacement oars, etc. must be done behind the touchline.

5.16.8 Judging

The finish is judged on the competitor's chest crossing the finish line. Competitors must finish on their feet in an upright position.

Judges shall be placed to observe the conduct of the event and to determine competitors' place at the finish.

5.16.9 Disqualification

In addition to the General Rules the following behavior shall result in disqualification: Failure to complete the course as defined and described.

5.16.10 Control of craft

Competitors must be in control of the surfboat up to and including the last course buoy. Competitors shall not be disqualified if they lose control of the craft on the return journey from the buoys.

Competitors may lose control on the way out without penalty provided they regain the craft and round the last turning buoy of each leg in control of the craft and complete the course.

One member of the crew must remain with the Surfboat and attempt to maintain control of the Surfboat until after their teammate has passed through the funnel and across the Finish line.

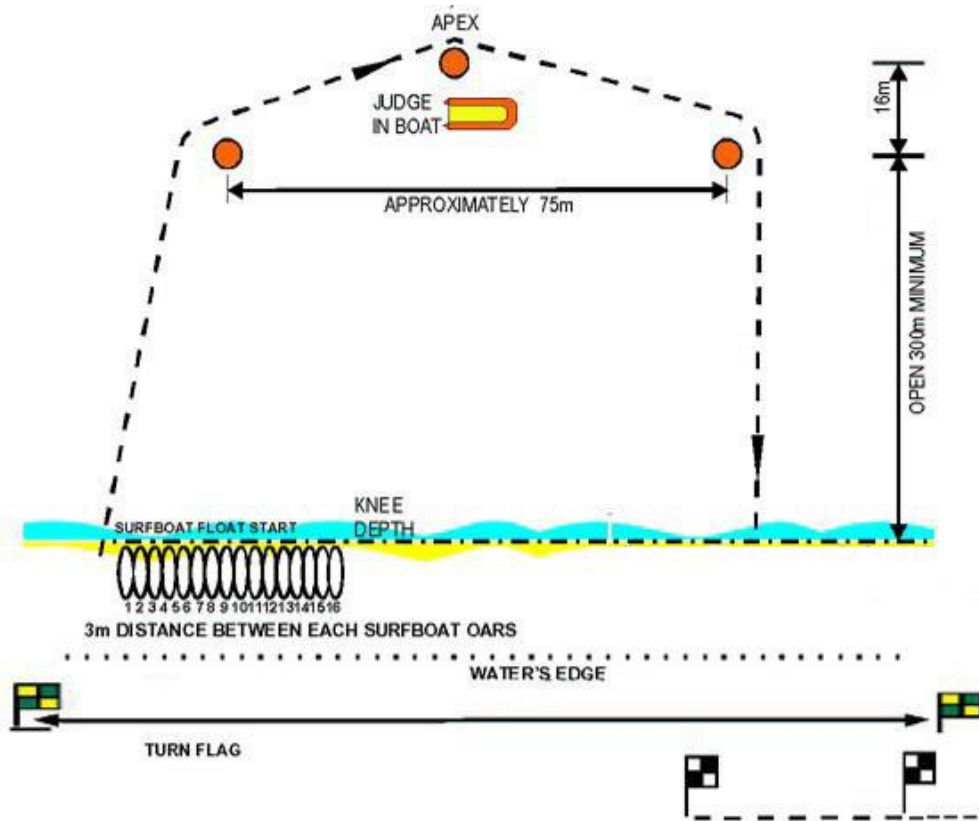

5.14 SURF BOAT RACE

Open Men and Open Women will be 3 laps.

Men's Masters events 30-34, 35-39, 40-44, 45-49 will be 2 laps only.

Events will start and finish at the finish line area.

Same as lap two and lap three are run in the Open event.

Masters Women 30+, and Men's 50+ will be 1 lap.

5.17 BOARD RESCUE

5.17.1 Event description

In this event, one member of the team swims approximately 120 m to a designated buoy, signals, and waits to be picked up by the second member of the team on a board. They both paddle to shore and cross the finish line on the beach with the board.

- a) Both competitors must start from the correct allotted position. i.e., the start/finish line. Competitors swimming to and signaling from the wrong buoy shall be disqualified.
- b) **First competitor:** From the allotted position on the start line on the beach, and on the start signal, the victim enters the water, swims to touch the allotted swimming buoy, signaling arrival by waving the designated flag or raising the other arm to a vertical position while in contact with the buoy.

The victim then waits in the water on the seaward side of the buoy.

***Note 1:** The buoy is defined as the buoy only and does not include any attaching ropes and/or straps. Competitors must visibly touch the buoy above the waterline before signaling their arrival at the buoy.

***Note 2:** Competitors may touch buoys and buoy ropes but are not permitted to use buoy ropes to drag themselves along the course to reach their allotted buoy.

- c) The Referee may determine an acceptable alternative method of clearly signaling the victim has touched the buoy.
- d) **Second competitor:** On the victim's arrival signal, and from the allotted position, the board rescuer crosses the start line, enters the water and paddles to the victim on the seaward side of the allotted buoy. The victim must make contact with the board on the seaward side of the buoy.

The board rescuer may not start before the victim signals arrival.

The board must round the buoy clockwise (right hand in) before proceeding to shore with the victim.

- e) The victim may place themselves on the front or rear of the board. The victim may assist by paddling the board on the return to shore.
- f) The finish is judged on the chest of the first competitor of each team to cross the finish line on his or her feet in an upright position, with both rescuer and victim in contact with the board.

***Note:** While both competitors need to be in contact with the board at the time the first competitor crosses the finish line to record a finish result, it is not necessary for the second competitor to cross the finish line on their feet and/or in contact with the board. However, all teams are requested to immediately move to the shoreward side of the finish line to assist with judging of the event and to enable any trailing teams to finish.

- g) The board rescuer may not start before the victim signals arrival. The board rescuer may cross the start/finish line for any reason and will not be disqualified provided he or she then resumes the correct start position to await the victim's arrival signal.
- h) Competitors are not permitted to hold or otherwise interfere with other competitors' boards or deliberately impede their progress

5.17.2 The Course

The course layout shall be as detailed in the following diagram.

The boards must be paddled around the allotted buoys clockwise (right side in) unless otherwise advised by the referee prior to the event.

5.17.3 Equipment

Boards: See Section 6 – *Equipment Standards*.

5.17.4 Judging

Judges shall be placed to observe the conduct of the event and to determine competitors' place at the finish.

5.17.5 Control of victim or board

Rescuers and victims may lose contact with the board on the return journey, but both must be in contact with the board when crossing the finish line.

5.17.6 Victim pickup

While it is not required that the entire board be on the seaward side of the allotted buoy, the victim must make contact with the board on the seaward side.

5.17.7 Disqualification

In addition to the *General Rule* the following behavior shall result in disqualification: Failure to complete the course as defined and described.

5.18 RESCUE TUBE RESCUE RACE

5.18.1 Event description

Four competitors from each team participate in this event: a “victim,” one rescue tube swimmer, and two rescuers. The victim swims approximately 120 m to a designated buoy, signals, and waits to be rescued by the rescue tube swimmer. As they return to shore, the remaining two rescuers enter the water to assist. The event finishes when the first competitor in a team crosses the finish line while in contact with the victim.

5.18.2 The Start

All four competitors assemble at their team’s allotted lane position at the start line facing the water. Prior to the start signal, the rescue tube swimmer and equipment must be on the shoreward side of the start/finish line. The rescue tube swimmer may hold or don the rescue tube and may hold the swim fins in his or her hands. Rescue tubes may be worn either with the loop over or across one or two shoulders, or over the shoulder and across the chest.

Fins may not be worn prior to crossing the start line.

- a) **Victim:** On the starting signal, the victim enters the water, swims to touch the allotted buoy, signaling arrival by raising the other arm to a vertical position while in contact with the buoy. The victim then waits in the water on the seaward side of the buoy.

The referee may determine an acceptable alternative method of clearly signaling the victim has touched the buoy, such as dipping the flag. Competitors must start from the correct allotted position. Competitors swimming to and signaling from the wrong buoy shall be disqualified.

*Note 1: The buoy is defined as the buoy only and does not include any attaching ropes and/or straps. Competitors must visibly touch the buoy above the water line before signaling their arrival at the buoy.

*Note 2: Competitors may touch buoys and buoy ropes but are not permitted to use buoy ropes to drag themselves along the course to reach their allotted buoy.

- b) **Rescue tube swimmer:** On the victim’s arrival signal, and from the correct allotted position, the rescue tube swimmer crosses the start line, dons the equipment at his or her discretion, and swims clockwise past the left side (viewed from the beach) of the designated buoy to the victim waiting on the seaward side of the buoy.

The rescuer secures the rescue tube correctly around the victim’s body and under both arms and clipped to an O-ring. The victim may assist with the securing and clipping of the rescue tube.

With the victim clipped into the rescue tube, competitors continue (clockwise) around the buoy towing the victim to the beach.

- c) **Rescuers:** After the rescue tube swimmer has started to tow the victim to the beach, the two rescuers, at their discretion, may cross the start line to enter the water and assist the rescue tube swimmer to bring the victim to the beach.

Victim must be dragged or carried to the finish.

5.18.3 The Finish

The finish is judged on the chest of the first team member crossing the finish line on their feet in an upright position while still in contact with the victim (the rescue tube need not be attached).

*Note 3: While it is not necessary to drag the whole of the victim beyond the finish line teams are requested to immediately move to the shoreward side of the finish line to assist with judging of the event and to enable any trailing teams to finish.

5.18.4 Notes:

All team members must start from their allotted positions at the start line.

Rescue tube swimmers and the rescuers, who have previously crossed over the start line (for whatever reason), will not be disqualified provided they return to the shoreward side of the start line prior to beginning their leg of the event.

At the start, rescue tube swimmers may place the rescue tubes and fins on the shoreward side of the start/finish line or may hold their fins and rescue tubes in their hands. The rescue tube lanyard may be worn.

Rescue tubes must be donned correctly, either with the loop over one shoulder, or over the shoulder and across the chest—at the competitor's discretion with the line fully extended.

The victim may assist the rescue tube swimmer in securing the rescue tube. Either may clip-in the rescue tube, but the victim must be clipped into the tube behind the buoy line.

Rescuers must tow the victim with the tube secured around the body and under both arms and clipped in an O-ring, and with the line fully extended.

The victim must not be towed on the stomach.

During the tow, the victim may assist by kicking and sculling with the arms under the surface but must not swim with an out-of-water arm recovery.

At no time, may the victim assist by walking or running, but the victim may assist by lifting the legs during the carry.

Only the rescue tube swimmer may use the swim fins. Rescuers shall not use any equipment or swim fins.

5.18.5 The course

As shown in the following diagram, the course shall be approximately 240 m. To ensure fair starts and finishes, alignment of the start line and finish line to the buoys may be altered at the discretion of the referee, depending on the prevailing sea conditions.

- a) **The start/finish line** a brightly colored cord stretched between the ten poles carrying flags, approximately 50 m apart—shall be located at the water's edge. Alignment of the start line to the buoys may be altered at the discretion of the referee, depending on prevailing sea conditions. The start line will also be the finish line. This line will be removed once competitors are in line and prior to the start to ensure the tube cannot catch it.
- b) **The swimming buoys** shall be placed as for the Surf Race, so that all competitors have an equal chance with regard to sandbanks and rips, etc.

5.18.6 Equipment

Rescue tube, swim fins: See Section 6 – *Equipment Standards*. Competitors must use rescue tubes provided by organizers.

5.18.7 Judging

Finish judges shall be positioned at each end of the finishing line at least 5 m from the flagpole and in line with each flagpole.

An in-boat course judge shall be positioned in line with the buoys as shown in the diagram.

Infringements recorded during the event observed by any of the judges shall be reported to the referee who shall adjudicate on the infringement with the judges concerned.

An in-boat judge observing an infringement, shall report to the referee as soon as practical and prior to the race result being declared.

5.18.8 Disqualification

In addition to the *General Rules* the following behavior shall result in disqualification:

Failure to complete the course as defined and described.

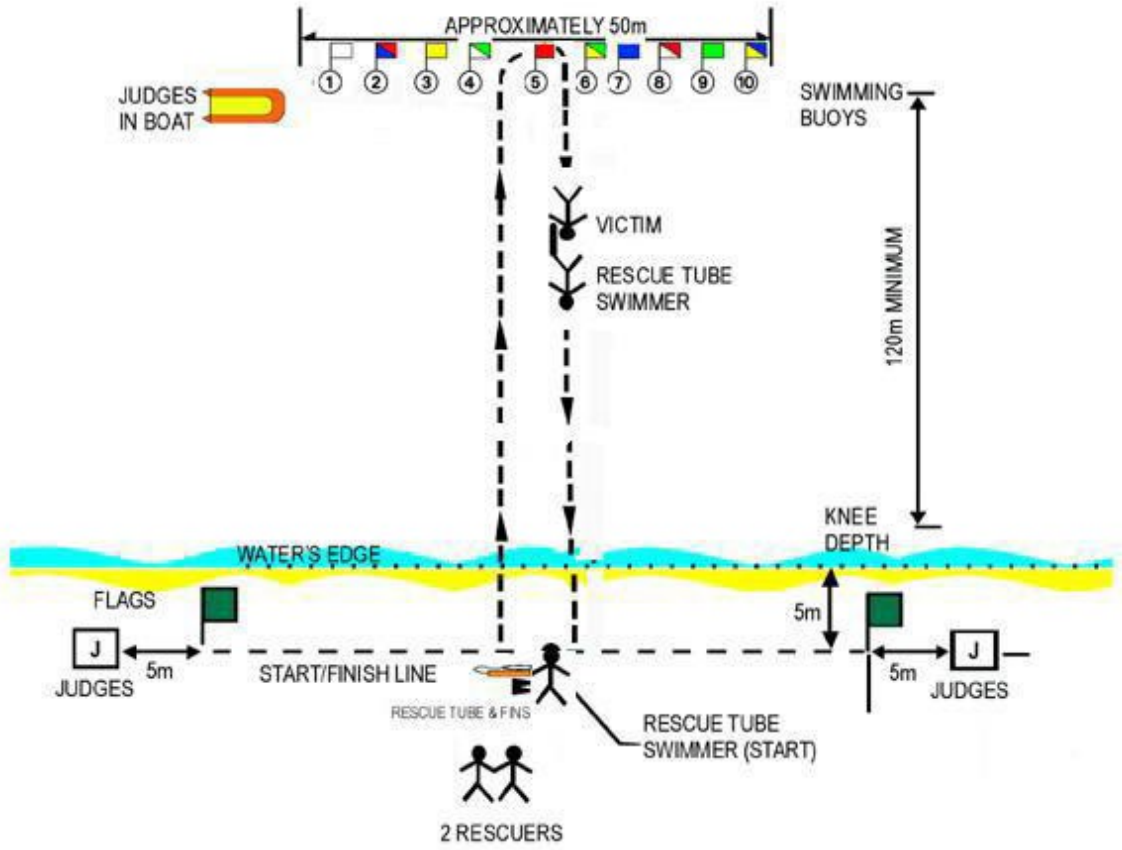

DISTANCES APPROXIMATE

5.16 RESCUE RACE

5.19 LANDLINE RESCUE RACE

5.19.1 Event Description

This event consists of 4 persons: one victim, one landline swimmer, and two landline pullers. Each team must consist of 4 Men in the Men's Landline Race, or 4 Women in the Women's Landline Race.

Prior to the start the victim is placed at the designated buoy and the swimmer and landline pullers assemble at their team's allotted position. The victim then waits in the water on the seaward side of the buoy.

At the start the landline swimmer swims the landline out approximately 120 m to a designated buoy, presents the rescue can to the victim, signals, and waits to be pulled back to shore by the 2 landline pullers. As the victim and landline swimmer return close to the shoreline, the two landline pullers enter the water to carry or drag the victim to the finish line.

The event finishes when the first competitor in a team crosses the finish line in their lane upright and in control while in contact with the victim.

*Note: USLA Chapters are restricted to entering a maximum of 4 total Landline Teams, regardless of gender.

(i.e., 2 Men's teams & 2 Women's teams, or 3 Men's teams & 1 Women's team, or 4 Women's teams...)

Each team will be assigned to a lane and corresponding flag buoy by random draw immediately before the heat. Heats will consist of no more than ten teams.

Rescue cans must be donned and worn correctly, either with the loop over one shoulder, or over the shoulder and across the chest, or around the waist – at the competitor's discretion.

Only the landline swimmer may use the swim fins.

The Course

As shown in the following diagram, the course shall be approximately 250 m.

The Start: On the starting signal the landline swimmer with shoulder strap or harness already on, swims in the assigned lane to the victim.

Only the landline pullers may feed line to the swimmer.

When the swimmer reaches the victim, the swimmer raises one arm in the air as a sign to the pullers to commence pulling.

The victim must hold onto the rescue can with both hands at all times and may kick.

Upon signal from the swimmer, the pullers pull victim and swimmer to the beach. The pulling area is restricted to the assigned lane and may be no greater than 25 meters long (see Figure 5.5).

Tying any knots in loop form is not permissible.

Carrying the line in loop form by the rescuer is permitted.

Launching the rescuer into the water by the pullers is not permitted.

The referee may determine an acceptable alternative method of clearly signaling the victim has touched the buoy, such as dipping the flag. Competitors must start from the correct allotted position. Competitors swimming to and signaling from the wrong buoy shall be disqualified.

*Note 1: The buoy is defined as the buoy only and does not include any attaching ropes and/or straps.

Competitors must visibly touch the buoy above the water line before signaling their arrival at the buoy.

*Note 2: Competitors may touch buoys and buoy ropes but are not permitted to use buoy ropes to drag themselves along the course to reach their allotted buoy.

The victims must keep in contact with their flag buoy until receiving the rescue can from the swimmer. At the start of the race the swimmer and the pullers must be behind the start line in their designated lane.

The Finish:

The two landline pullers, at their discretion, may cross the start line to enter the water and assist the landline swimmer to bring the victim to the beach. All four team members must cross the finish line in their assigned lane in contact with each other. The victim may not aid in any way (walk, crawl, etc.) with their transport across the finish line.

When the victim is being carried from the water, they must hold on to the rescue can with at least one hand. Victims must be carried across the finish line.

The Finish is judged on the chest of the first team member crossing the finish line on their feet in an upright position while still in contact with the victim.

At no time, may the victim assist by jumping, walking or running towards the finish line, but the victim may assist by lifting the legs during the carry.

*Note 1: While it is not necessary to drag the whole of the victim beyond the finish line teams are requested to immediately move to the shoreward side of the finish line to assist with judging of the event and to enable any trailing teams to finish.

5.19.3 Equipment

Rescue can-"Mini or Maxi" with shoulder or waist harness, swim fins to be worn by the landline swimmer, 800 feet landline, no less than one-quarter (1/4) inch in diameter. Landline must be kept in some sort of container (a bucket, on a reel, in a bag), but may not be laid out prior to the start of the race. See Section 6-*Equipment Standards*.

5.19.4 Judging

Finish judges shall be positioned at each end of the finishing line at least 5 m from the flagpole and in line with each flagpole.

An in-boat course judge shall be positioned in line with the buoys as shown in the diagram.

Infringements recorded during the event observed by any of the judges shall be reported to the referee who shall adjudicate on the infringement with the judges concerned. An in-boat judge observing an infringement, shall report to the referee as soon as practical and prior to the race result being declared.

5.19.5 Disqualification

In addition to the General Rules the following behavior shall result in disqualification: Failure to complete the course as defined and described.

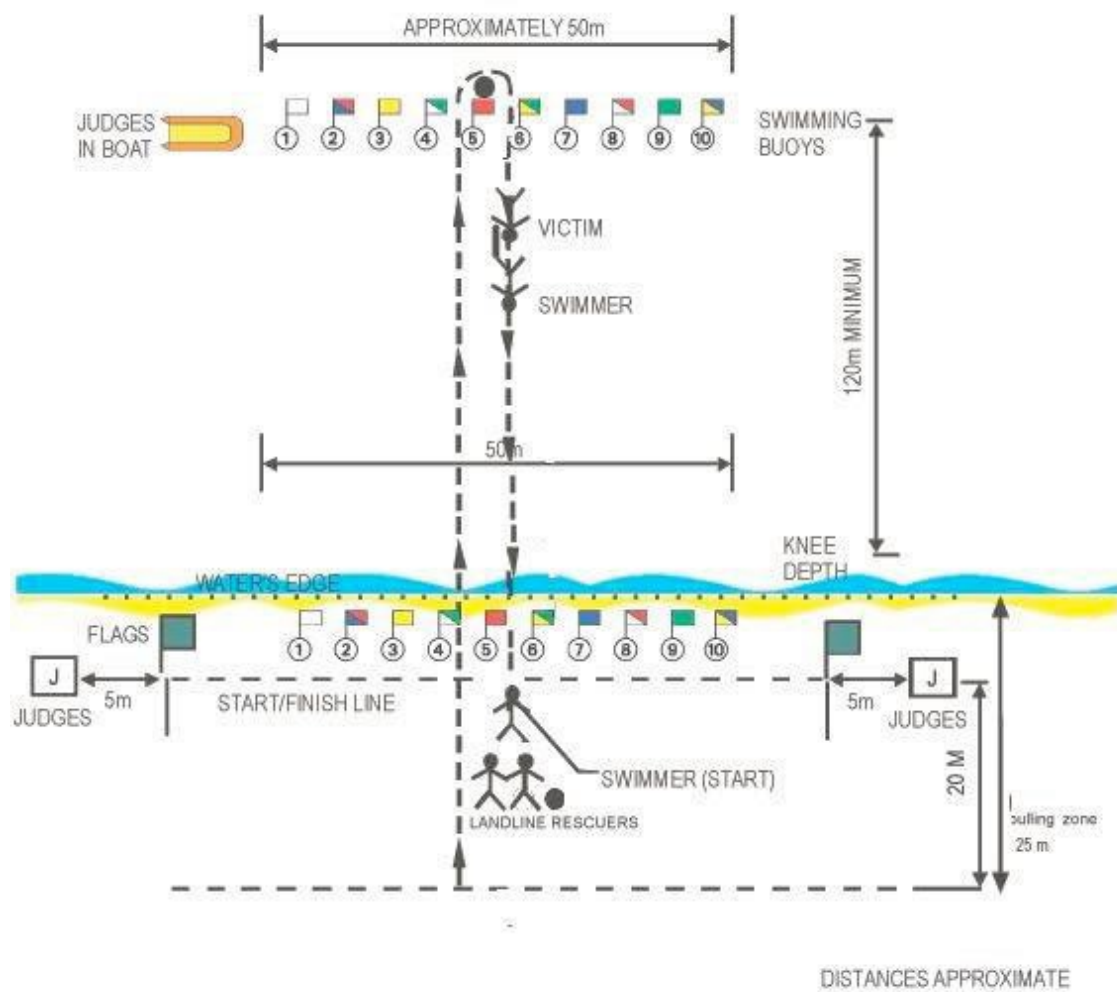

5.17 LAND LINE RESCUE RACE

5.20 BEACH RELAY

5.20.1 Event description

Teams of four individuals compete in baton relay fashion over a 90-meter course.

To start, two competitors take positions in their allotted lane at each end of the course.

After the start each competitor completes a leg of the course with a baton held in either hand and passes the baton at the conclusion of the first, second, and third legs to the next runner.

All competitors shall finish their leg of the event on their feet and in an upright position.

Competitors are not permitted to interfere with the progress of other competitors.

5.20.2 The Start

The start shall be with the first competitor taking the mark.

The finish will be judged by any part of the torso of the 4th member of the relay team crossing the finish line. Competitors shall be placed at the finish in the order in which their bodies (*i.e.*, the "torso," as distinguished from the head, neck, arms hands, legs, or feet) crosses the finish line.

Baton changeovers

The baton shall be exchanged in the following manner:

- a) The competitor coming in to exchange the baton must carry the baton to the front line. (The baton may not be thrown to the next competitor.)
- b) Competitors receiving the baton on the first, second, and third exchange can be moving while taking the baton but will be disqualified if any part of the body or hands cross the front line before taking possession of the baton.
- c) If a baton is dropped during the exchange, the receiver may recover the baton (ensuring that there is no interference to other competitors) and continue the race.
- d) If a baton is dropped at any other stage, the competitor may recover the baton (providing that there is no interference to other competitors) and continue the race.

5.20.3 The Course

The course shall be as shown in the following diagram.

Equipment and apparel

Shorts and shirts, which comply with team uniform requirements, may be worn at the competitors' discretion.

Different colored singlets or vests may be required by the officials to assist in judging the finish.

Baton:

See Section 6 – *Equipment Standards*.

5.20.4 Judging/changeovers

In general, judging shall be as for the beach sprint with the Chief Referee, Course Judge, and the Finish Judges assuming similar duties in regard to the start and finish.

Course judges shall be appointed to check the changeover lines for infringements at each end during the changeovers.

Any infringements observed by the course judges shall be reported to the referee in the case of the changeovers.

5.20.5 Disqualification

In addition to the General Rules the following behavior shall result in disqualification: Failure to complete the course as defined and described.

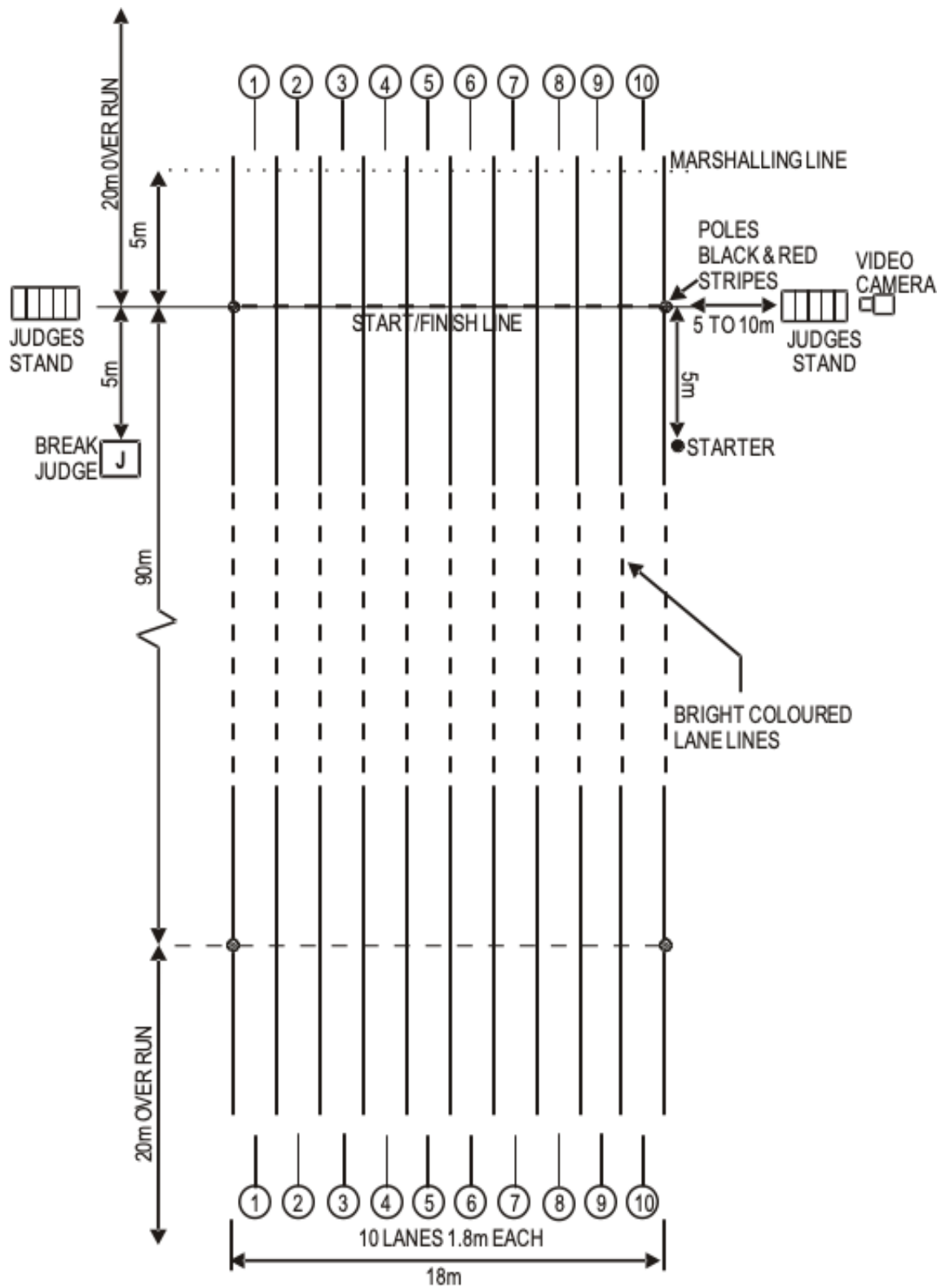

DISTANCES APPROXIMATE

Camera

Electronic
Replay

Recorders
Tent

Black & Red
Stripes

ir

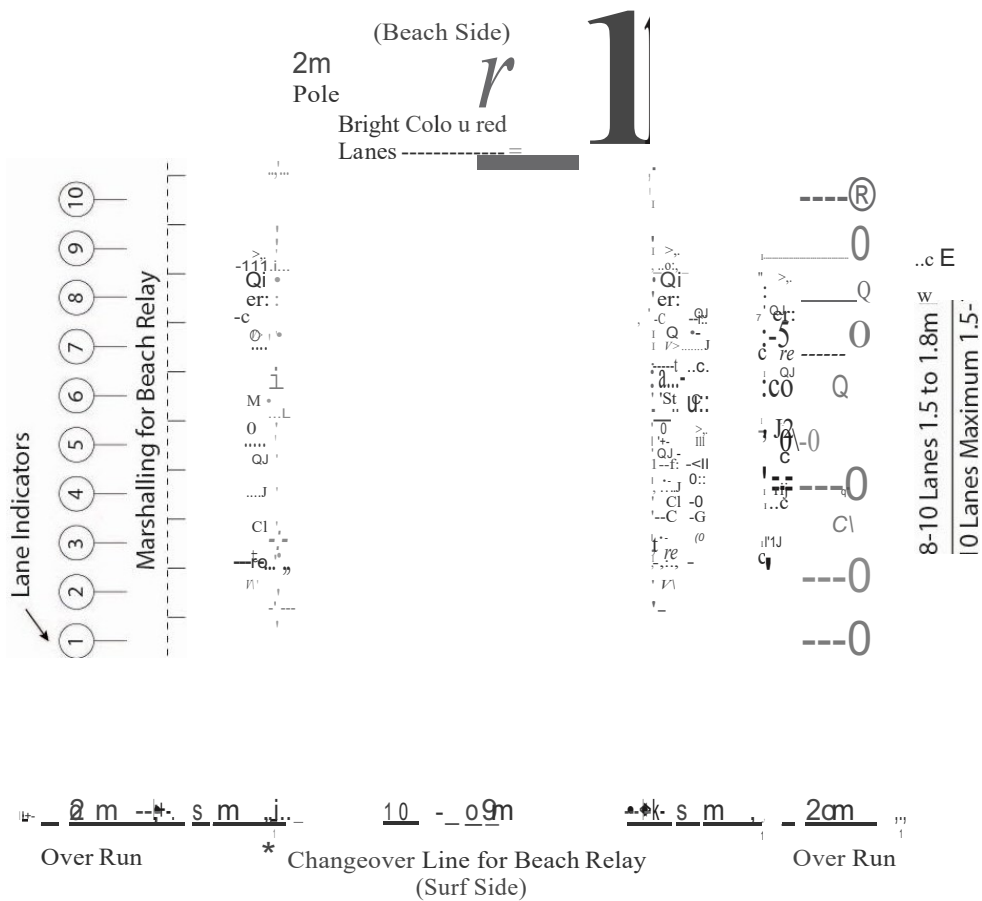

8-10 Lanes 1.5 to 1.8m
10 Lanes Maximum 1.5-

6
5
4
3
2
1

Judges
Stand

5.21 TAPLIN RELAY

5.21.1 Event description

The Taplin Relays are a variation of the individual Ironman/Ironwoman events. Teams of 4 competitors (1 swimmer, 1 board paddler, 1 surf ski paddler, and 1 runner) cover the course in a sequence of legs determined by draw at the start of each competition. The run leg is always the final leg. If the ski leg is first, competitors shall start with a typical in-water start.

Except for the differences noted in this section, the conditions of racing of each leg are as generally required for the individual conditions of that discipline including the rules governing the component disciplines: surf ski races, board races, surf races, beach sprints.

To ensure fair starts and finishes, alignment of the start line and finish line to the buoys may be altered at the discretion of the referee, depending on the prevailing sea conditions.

Competitors must commence their leg of the event from the correct allotted beach position.

Note 1: The second and third competitors do not need to cross the start/changeover line to enter the water after being tagged.

The starting positions are reversed for the board and surf ski legs. For example, in a 16-team race in which a team has drawn position 1: the initial craft leg is commenced from position 1 but the other craft leg is commenced from position 16.

1st & 3rd competitor's starting position	1	2	3	4	5	6	7	...16
2nd competitor's starting position	16	15	14	13	12	11	10	...1

Note 2: If the swim leg is the second or third leg of the race, competitors are to commence their leg of the race from the same drawn position of their team in the leg immediately prior to the swim leg.

The following event description assumes the order to be swim – board – ski – run.

The course direction is clockwise.

Swim leg

From a beach start, swimmers enter the water, swim around the swimming course flag buoys White #1 to Yellow/Blue #10, and return to the beach, run around the 2 beach turning flags to tag the board paddlers who are waiting with their boards, feet on, or on the shoreward side of, the start/changeover line.

Board leg

Board paddlers enter the water with their boards; pass swim buoy White flag #1 on the outside; round the 2 board course buoys; return to the beach passing swim Flag buoy Yellow/Blue #10 on the outside; round the 2 turning flags, and through the start/changeover line to tag the ski paddlers, who are waiting with their surf skis and paddles in approximately knee depth water. On their return, board paddlers may leave their boards at the water's edge.

Surfski leg

Surfski paddlers paddle around the surfski course buoys and return to shore to tag the runners waiting at the water's edge or in the water.

Paddlers must pass on the outside of all buoys.

Paddlers shall not cut through swim course or board course.

The location of the tag is at the discretion of the team provided it occurs after the last swim course buoy and before the first turning flag.

Run leg

Runners then round 1 turning flag, pass the other flag on the shoreward side, and continue to the finish between the 2 finish flags.

Note: It is permitted to tag the competitor anywhere from the shoreward side of the last turning buoy to the first turning flag on the beach.

All tags must be performed above the water surface so that they are visible.

In addition, runners are permitted to enter the water to tag the incoming competitor and may wade, porpoise off the bottom, catch waves and or run to the turning flag but are not permitted to swim at any time (this includes taking any over arm action to either catch or stay on a wave).

Equipment

Surf ski, paddle, board: See Section 6 –Equipment Standards. Each tea

Team members shall place gear adjacent to the respective starting areas for the various craft.

Equipment removal: To assist with the safe conduct of the event, team members and/or handlers may remove damaged or abandoned equipment from the course during the race provided the progress of other competitors is not obstructed.

Handlers shall:

- (a) Wear a competition cap.
 - (b) Wear a distinctive high-visibility vest as required by competition organizers if entering the water beyond knee depth.
 - (c) Make every effort to ensure that they and the equipment they are handling do not impede other competitors (otherwise disqualification of the competitor may result).
 - (d) Comply with all instructions of the officials.
- Apparel: In the beach sprint course, shorts and shirts, which comply with team uniform requirements, may be worn at the competitors' discretion.

Judging

The finish is judged on the competitor's chest crossing the finish line.

Competitors must finish on their feet in an upright position.

Judges shall be placed to observe the conduct of the event and to determine competitors' place at the finish.

Control of craft

Competitors must be in control of the surfski or board up to and including the last course buoy.

Competitors shall not be disqualified if they lose control of the craft on the return journey from the buoys. Competitors may lose control on the way out without penalty provided they regain the craft and round the last turning buoy in each leg in control of the craft and complete the course.

Disqualification

In addition to the General Rules the following behavior shall result in disqualification: Failure to complete the course as defined and described.

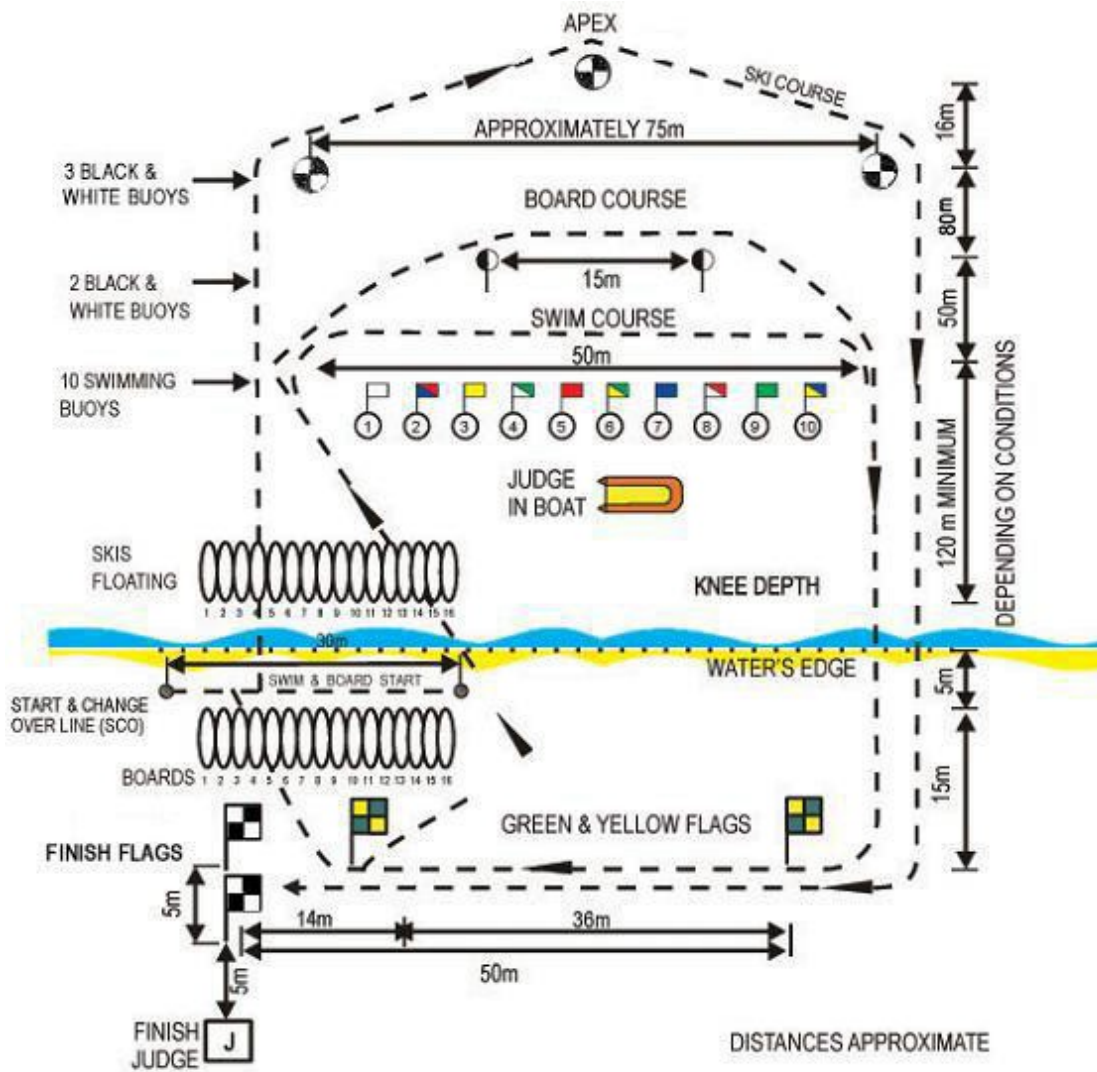

5.19 TAPLIN RELAY

5.22 BOARD RELAY

5.22.1 Event description

The Board Relay event shall be conducted under the general rules of the Board Race event. Teams shall consist of three competitors, who may use the same craft, but 2 or 3 boards is preferred.

First competitor: The first competitors shall be started as in the Board Race and complete the course marked by the board race buoys. Competitors may then leave their board (anywhere after rounding the buoys), round the two green and yellow flags, and tags with the second competitor on the designated board changeover line.

The second competitor: The second competitor completes the same course, rounds the two turning flags, and tags with the third competitor on the designated board changeover line.

The third competitor: The third competitor completes the same course, rounds one turning flag, passes the other on the shoreward side, to finish between the two finish flags.

The second and third competitors in the board relay event shall be positioned with their feet on, or shoreward of, the changeover line. The second and third competitors do not need to cross the board start line to enter the water after being tagged.

Competitors in the board relay events must commence their leg of the event from the correct allotted position. The first and third competitor in each team commence from the team's drawn starting position. However, the drawn starting position is reversed for the second competitor in each team.

Forexample, in a 16-team race in which a team has drawn position 1: the first competitor commences from position 1; the second competitor commences from position 16; the third competitor commences from position 1

1st & 3rd competitor's starting position	1	2	3	4	5	6	7	8	...16
2nd competitor's starting position	16	15	14	13	12	11	10	9	...1

Competitors are not permitted hold or otherwise interfere with other competitors' boards or deliberately impede their progress.

5.22.2 The course

The course layouts shall be as detailed for the Board Relay Race and shown in the following diagrams. 2 course variations are presented:

- a) the full distance board relay can proceed around the Board Race course buoys,
or
- b) the shortened course to proceed around the Ironman/Ironwoman/Taplin Relay Board leg course.

To ensure fair starts and finishes, alignment of the start line and finish line to the buoys may be altered at the discretion of the Chief Referee, depending on the prevailing sea conditions.

5.22.3 Equipment

Boards: See Section 8 – Facility and Equipment Standards and Scrutineering Procedures.

- a) The use of a replacement board is permitted provided that the competitor recommences the race from the start line. Replacement boards may be brought to the start line by fellow team members providing they do not cause any interference to other competitors.

- b) Members of the team or other members authorized by the Chief Referee shall ensure that any craft used by any of the other team members does not cause any interference to another team or competitor in the race. Boards shall be removed as soon as possible from the water's edge to avoid congestion and possible damage.
- c) If a club enters more than one team in an event, each team shall be required to wear distinguishing numbers or letters marked on their arm, leg, or caps.

5.22.4 Judging

The finish is judged on the competitor's chest crossing the finish line. Competitors must finish on their feet in an upright position.

5.22.5 Control of craft

Competitors may lose contact with or control of the board on the way out, provided they regain the board and round the last course buoy in contact with the board and complete the course.

Competitors must paddle their board around the last course buoy and shall not be disqualified if they lose contact with or control of their board after the last course buoy on the return.

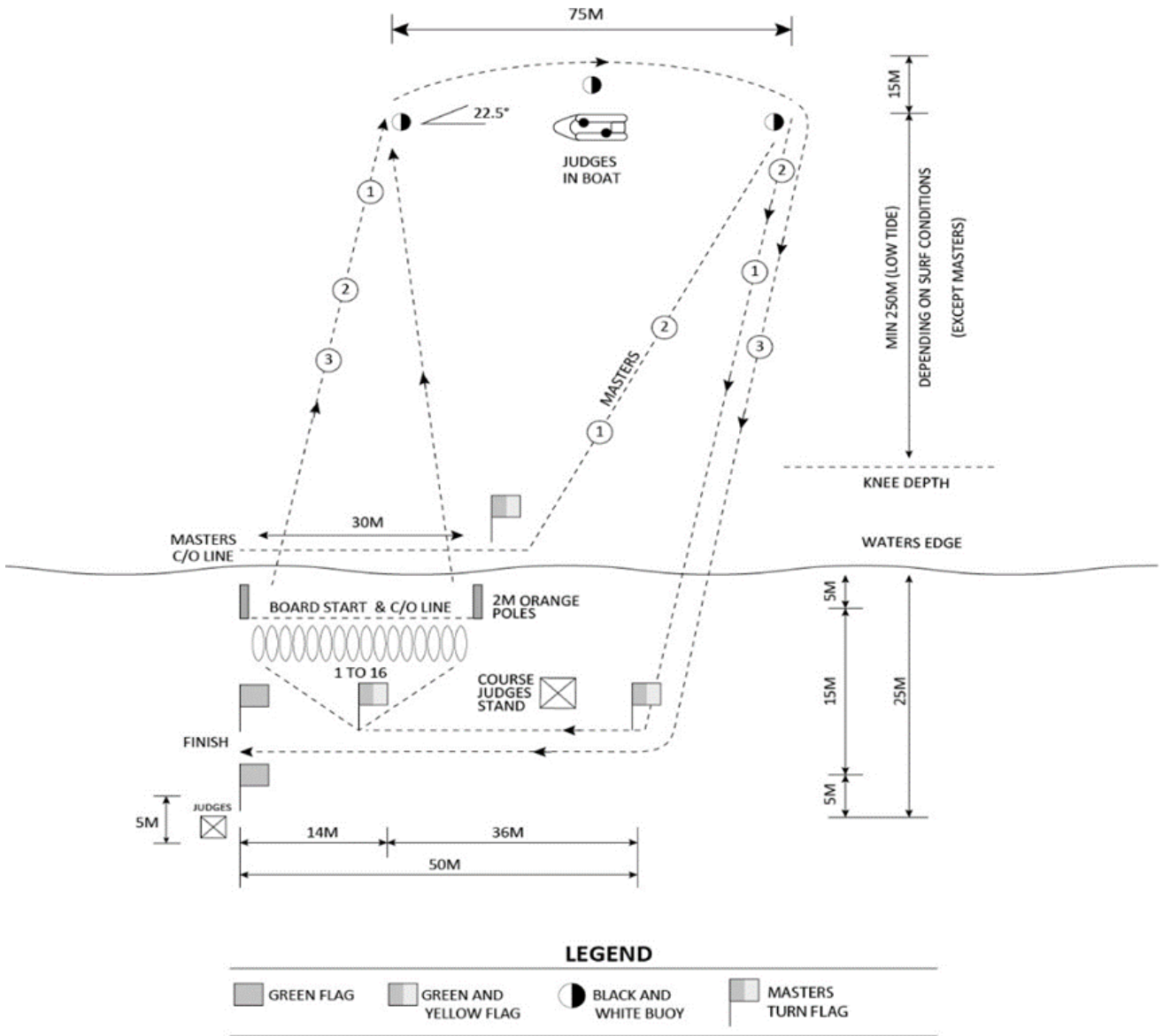

ILS Full distance Board Relay course proceeds around the Board Race course buoys

Note 1: USLA Board Relay Short Course variation is shown below

**5.22.6 USLA Board Relay Short Course Procedure Variation for flatwater or small surf venues
(also ILS Masters Board Relay Course Procedure Variation)**

- a) The Board course buoys for the USLA Short Course and ILS Masters Board Relay shall be as per the Ironman/Ironwoman/Taplin Relay Board leg. As per the Event Description all 3 Board Relay paddlers enter the water with their boards; paddle past the White flag Lane #1 Swim buoy on the outside; round the 2 Surf Race/Ironman/Taplin board leg course buoys; return to the beach passing Yellow/Blue flag Lane #10 swim buoy on the outside; round the 2 turning flags, and through the start/changeover line to tag the next paddler, who are waiting with their boards at the start/change over line. On their return, board paddlers may leave their boards at the water's edge.
- b) The first competitor shall start the event as per the standard Relay event and paddle around all buoys as per the Taplin Relay course for the Board leg. When the first competitor has rounded the last turning buoy, the competitor may leave their board at their discretion, round the single green/yellow flag placed either on the shoreline or at knee depth water (dependent on surf conditions and to minimize the run distance) and visibly tag with the second competitor at a designated changeover line on the seaward side of this single flag.
- c) The second competitor then proceeds around the appropriate buoys. When the second competitor has rounded the last turning buoy, the competitor may leave their board at their discretion, round the single green/yellow flag either on the shoreline or at knee depth water (dependent on surf conditions and to minimize the run) and visibly tag with the third competitor at a designated changeover line on this seaward side of this single flag.

The third competitor will then proceed around the appropriate buoys. When the third competitor has rounded the last turning buoy, the competitor may leave their board at their discretion and complete the standard Board Relay course by rounding the standard green and yellow turning flag on the beach and pass the other green and yellow flag on the shoreward side to finish between the two finish flags.

Note:

All other conditions shall remain unaltered from the standard course.

Note 2: the beach setup relative to the positioning of the buoys may be adjusted dependent on the sea conditions.

5.22.7 Disqualification

In addition to the General Rules in Section 2 and those outlined in 4.1 through 4.3, the following behavior shall result in disqualification: Failure to complete the course as defined and described (DQ12)

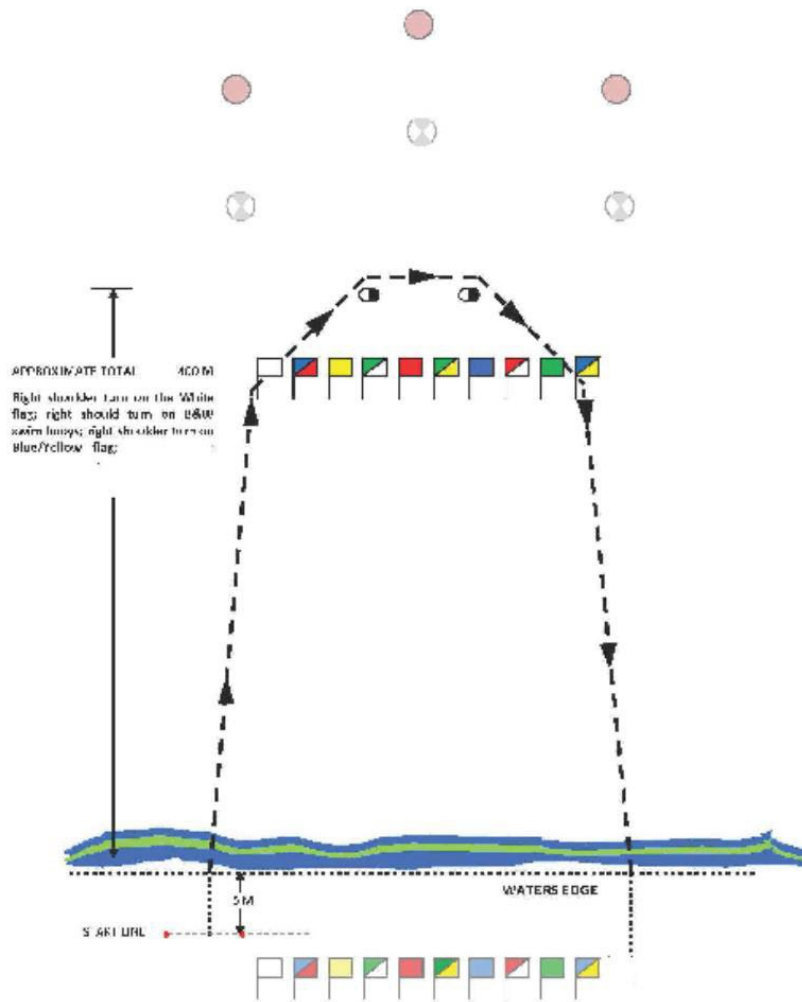

6.11.7 USLA Short Course Board Relay Procedure Variation for flatwater or small surf venues

USLA Short Course Board Relay Procedure Variation - for flatwater or small surf venues

Section 6- EQUIPMENT STANDARDS

6.1 RESPONSIBILITY FOR EQUIPMENT

USLA shall provide the following equipment, which *must be used by competitors*:

- Batons for Run Relays and Beach Flags Event
- Rescue Tubes for the Rescue Race

All other craft and personal equipment shall be provided by competitors provided that each piece of equipment to be used meets the specifications provided in this Section.

The USLA has adopted the ILS equipment standards for the following equipment: Where appropriate, allowable tolerances are recorded as “(± 2 cm)” meaning a tolerance of plus 2.0cm and minus 2.0cm are allowed. Where appropriate, dimensions and weights are recorded as “minimum” or “maximum” allowed. If a craft’s weight is under the minimum requirement, the correct amount of weight must be added permanently to qualify for participation.

6.2 Scrutineering of equipment

Scrutineering of equipment prior to the competition will be carried out by the duly appointed officials. Competition bulletins/circulars shall detail the procedures for checking equipment.

The USLA Competition Event Officials reserves the right to re-inspect competition equipment at any time during the competition.

Equipment found to contravene USLA / ILSF specifications shall be subject to disqualification, which may result in the disqualification of the competitor using the equipment and the possible disqualification of the full team.











Appeals against rulings of equipment ineligibility are permitted.

6.3 SWIMWEAR

- a) Swimwear for both ILS pool and ocean swim events and swim leg of events must comply with the following standards:

Note 1: All swimwear stamped as being FINA compliant for Stillwater swimming shall be acceptable for use in ILS competition.

- b) The material and construction used in swimwear to be worn in all ILS pool and ocean events shall be:
- Only textile woven fabric(s) shall be permitted. Non-woven and/or non-permeable (e.g., wetsuit type) materials shall not be permitted.
 - The material used shall have a maximum thickness of 0.8 mm.
 - Other than string ties for the tops of man swimwear, the bottom and/or top of woman two-piece swimwear, and the back of woman one-piece open back swimsuits, no zippers or other fastening systems shall be permitted.
 - The swimsuit worn by competitors shall not aid in their buoyancy.
 - Swimwear that provides flotation, pain reduction, chemical/medical stimulation or other external stimulation or influence of any type shall be prohibited.
 - No outside application on the material shall be permitted. (Note: manufacturer brandings, club names or similar are permitted).

Man Swimsuits					
Full Length	Long	Long Legs	Knee length	Square Leg	Short
Not Allowed	Not Allowed	Not Allowed	Allowed	Allowed	Allowed
					
Woman Swimsuits					
Full Length	Zippered Back	Knee Length, Open Back	Short, Open Back	Two Piece	
Not Allowed	Not Allowed	Allowed	Allowed	Allowed	
					

6.4 RESCUE TUBES

- a) *Source of Buoyancy.* The material shall be closed cell plastic foam, durable and flexible.
- b) *Buoyancy.* The rescue tube shall have a minimum buoyancy factor of 100 Newton's in fresh water.
- c) *Color.* The body of the Rescue Tube shall be a color-fast red, yellow, or orange (impregnated, painted, or covered).
- d) *Flexibility.* The body of the Rescue Tube shall be of such a nature as to be able to roll within itself.
- e) *Strength.* Webbing, leash, and fittings shall be able to withstand a minimum of 1,000 pounds stress in a longitudinal direction without damage.
- f) *Stitching/thread.* Stitching shall be locked with similar properties of the materials being sewn.
- g) *Rescue Tube Dimensions:*
 - i. Tube Body Length (L): 875-1000mm
 - ii. Tube Body Breadth (B): 150mm
 - iii. Maximum Tube Body Thickness (T): 100mm maximum.
 - iv. The distance from the extremity of the clip to the extremity of the first O-ring shall be a minimum of 1100 mm to a maximum of 1400mm.

- v. The distance from the extremity of the clip to the extremity of the O-ring shall be a minimum of 1300mm to a maximum of 1650mm.
- h) *Leash*: The length of the leash from the first O-ring to the lanyard webbing shall be a minimum of 1900 mm to a maximum 2100mm. The leash shall be a synthetic type rope which is UV treated.
- i) *Webbing connections*: Webbing used for the connection of O-rings/clips to the body of the tube shall be 25mm (± 2.5 mm) wide woven nylon.
- j) *Lanyard*: Webbing for the lanyard shall be 50mm (± 5.0 mm) wide woven nylon with a minimum length of 1300mm to a maximum of 1600mm. The circumference of the lanyard loop shall be a minimum of 1200mm.
- k) *O-rings*: O-rings shall pass, stainless steel (welded) OR NYLON. If nylon, the rings shall be UV treated. O-rings shall be 30mm (± 4.0 mm) in diameter, having no sharp edges or protrusions that may cut or injure the rescuer or victim.
- l) *Clips*: The clip shall be a brass or stainless steel snap hook with an overall length of 70mm (± 7.0 mm). It shall have no sharp edges or protrusions that may cut or injure the rescuer or victim.

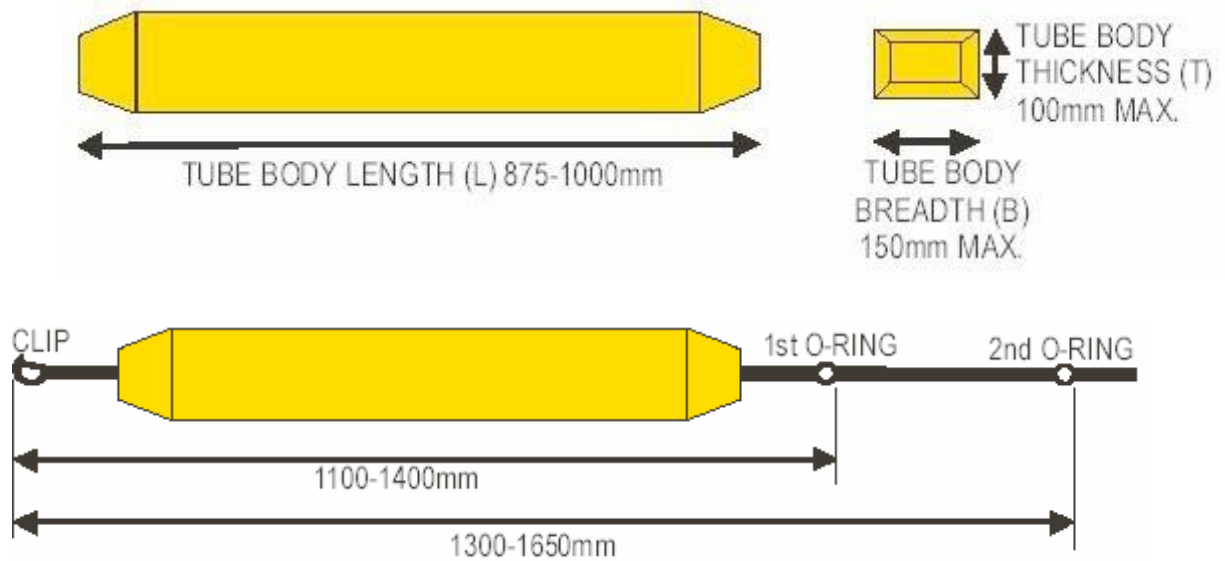

6.5 RESCUE CAN

Mini or Maxi rescue cans may be used in the Landline Rescue Race with shoulder or waist harness

6.6 LANDLINE

A Landlines total length shall be no more than 800 feet / 243.84 meters of rope or Line.

The Landline rope must be no less than one-quarter (1/4) inch in diameter. The Landline must be kept in some sort of container-in a bucket, on a reel, or in a bag, but may not be laid out prior to the start of the race.

6.7 SWIM FINS

Fins are measured while not worn.

Swim fins used in competitions shall comply with the following ILS specifications:

- a) *Length:* maximum overall length 65cm, including “shoe” or ankle strap (ankle strap extended).
- b) *Width:* 30cm maximum at the widest point of the blade

SWIM FINS

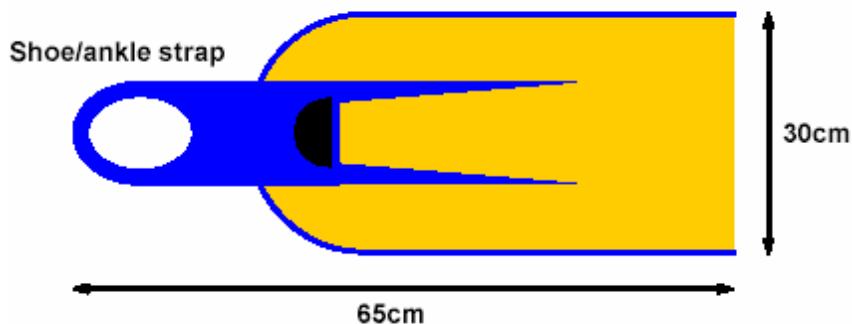

7.7 SURFSKIS

Surfskis must conform to ILS specifications including the following:

- a) *Weight:* Minimum 18kg (39.68 pounds)
- b) *Length:* Maximum 5.80m (19.03 Feet or 228.3 Inches)
- c) *Width:* Minimum width at the widest point of the hull is 480mm (18.9 inches) and shall not include any rubbing strips, molding or additional protective moldings.
- d) Detailed specifications are available in “Equipment Specifications” at www.slsa.asn.au

7.8 BOARDS

Boards must conform to ILS specifications including the following: a. *Weight:* Minimum 7.5kg (16.53 pounds)

- a) *Length:* Maximum 3.2m (10’6”)
- b) Detailed specifications are available in “Equipment Specifications” at www.slsa.asn.au

7.9 BATONS (BEACH FLAGS)

Beach flags batons and beach relay batons shall be made of flexible material (e.g. flexible hose)

- a) *Length:* A maximum of 30cm (12”) and a minimum of 28cm (11”)
- b) *External Diameter:* Approximately 25mm (± 1mm or .9843 inches)
- c) Batons shall be of a color so as to be easily visible when placed in the sand.

7.10 SURFBOATS

Two Man Surfboat shall conform to the following USLA specifications.

Helmets shall be worn by all Rowers and all in water Handlers.

A soft rescue tube shall be carried in every surfboat during racing.

- a) Length is not to exceed 20 feet 6 inches.
- b) Length bottom is not to exceed 16 feet 6 inches, including any rocker.
- c) Beam is not to exceed 72 inches at gunwale.
- d) Width is not to be less than 21 inches at the widest outside bottom measurement across the chines.
- e) Gunwale Height (freeboard). When calculating gunwale height, surfboats will be placed at level on a flat plane. Gunwale height will be the measurement taken from the top of the gunwale to the plane, at 90 degrees to that plane. At no place shall the gunwale height be less than 21". At the bow, and within one foot of the bow, at the gunwale, the gunwale height shall not be less than 34". At the stern, and within one foot of the stern, at the gunwale, the gunwale height shall be no less than 30".

These measurements pertain to Schock-type dories only.

- f) The "crown" of surfboat deck will be allowed a tolerance of plus or minus one inch.
- g) The minimum weight, including thwarts and oar locks, shall not be less than 300 lbs.
- h) The span between oarlock centers at the oar well centers will be determined by the individual.
- i) Construction material is to be left to the builder's preference.
- j) Non-binding foot straps will be permitted, however, sliding seats will not be allowed.
- k) Oars can be of any construction and may be individually shaped or formed as desired.
- l) Boat markings: lettering and numbers on boats are required.
Letters and numbers must be placed on the bow of the boat in block style and of a contrasting color.
Minimum sizes-- 16 inches high, 12 inches wide, 3 inches in thickness.
- m) Surfboats used in competition since 1960 not meeting these standards will be allowed to continue racing as long as they meet minimum weight.

7.11 FLAGLINE BUOY ANCHORING SYSTEM

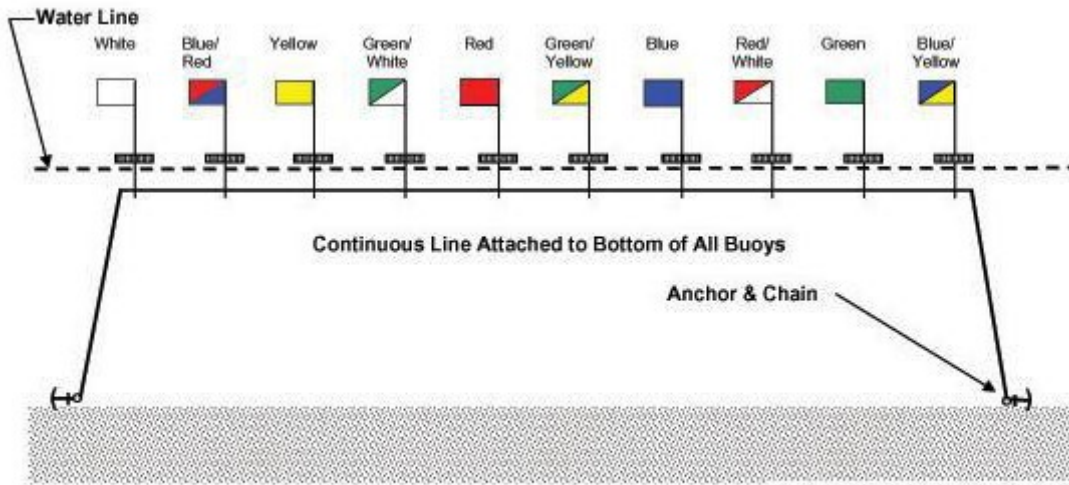

Buoy Anchoring System
Drawing Not to Scale

7.12 BUOY CONSTRUCTION DETAIL

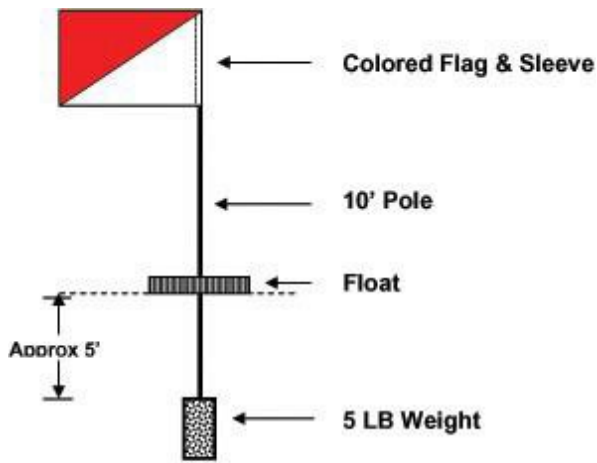

Buoy Construction Detail
Drawing Not to Scale

7.13 BOARD, SURFBOAT AND SURFSKI COURSE OVERVIEW

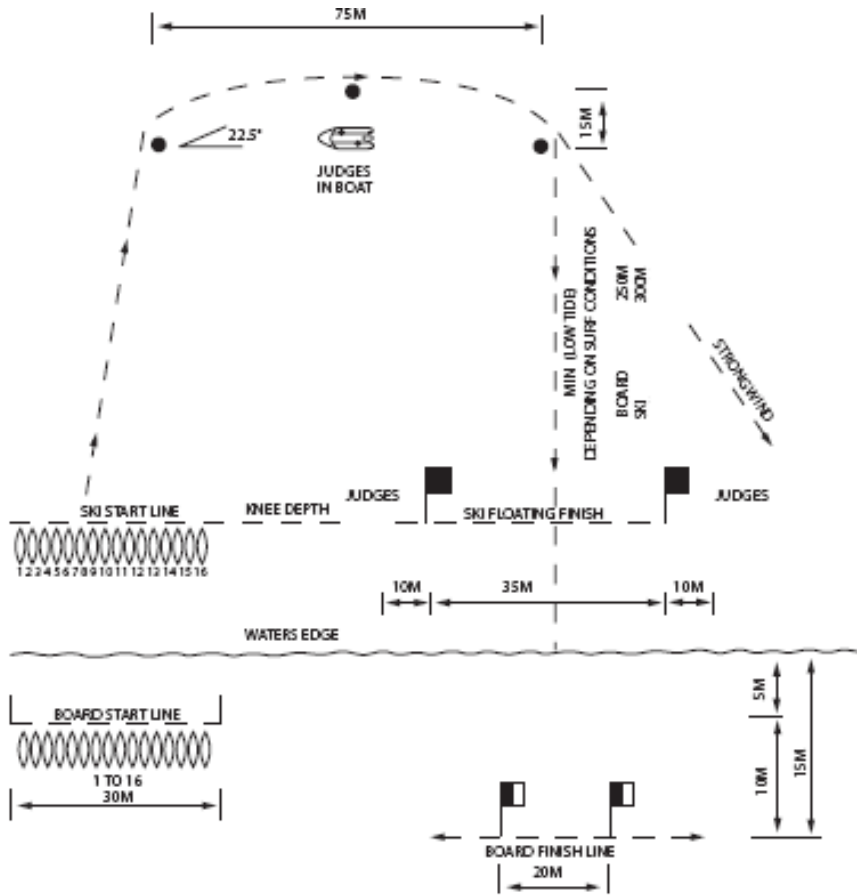

(Distances approximate only)

LEGEND

BOARD AREA

-  BLACK & WHITE FLAG ON 4M POLE
-  BLACK & WHITE BUOY

SKI AREA

-  ORANGE FLAG ON 4M POLE
-  ORANGE BUOY

NOTE: THE BEACH SET UP RELATIVE TO THE POSITIONING OF THE BUOYS MAY BE ADJUSTED DEPENDENT ON THE SURF CONDITIONS.

7.14 NATIONAL CHAMPIONSHIP COURSE OVERVIEW

